



Product sheet:
Process Fan Upgrade kit
MX 1500 - 2800

Benefits:

- Energy consumption reduced by 50%
- Return on investment (ROI) of less than 2 years
- Green Tech energy efficient fan motor
- Flexible fan motor design allows for horizontal or vertical discharge
- Decreased sound level

Process Fan Upgrade Kit for Munters MX Series

Replacing an old and original fan with a 3kW motor for an EC fan upgrade offers the same air volume and static pressure with only 1.6kW power consumption. The EC (Electronic Commutator) fan is a permanent magnet motor that has an electronically controlled stator field,

compared with the voltage induced stator field of an AC induction motor. The EC motor allows proportional control over a 0-100% range with no induction present. This can be done via a pressure transducer or manual potentiometer control, either 0-10vdc or 4-20mA.

The EC fan is very versatile for installation and designed with removable feet, that allows for vertical discharge as well as the standard horizontal discharge. This allows for more flexibility, especially in tight installations.

Technical Specifications

EC centrifugal fan

Maximum airflow	m ³ /h	4025
Airflow nominal	m ³ /h	2700
Available static pressure	Pa	1535
Total power	kW	3,24
Operating temperature	°C	-25 to 40
Voltage	V/Hz	400 VAC at 50/60 Hz
Current	A	4,9
IEC protective class (unit)	IP	54
Insulation Class		B
Weight	kg	15

Order information

Article no 170-031811-001
 Complete EC fan with flange mounted solution for both vertical and horizontal installations.

Installation

The kit is available only for installation by Munters Service Team, and also includes the final adjustment of airflows to secure optimal performance.

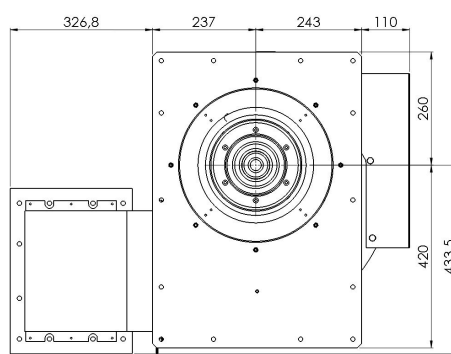
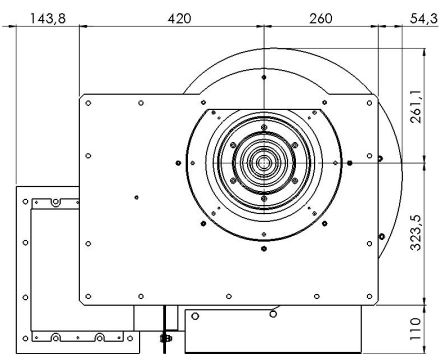
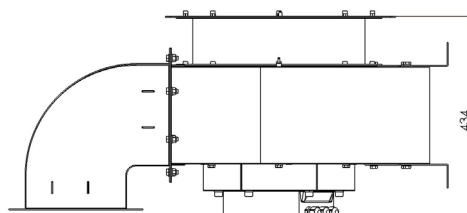
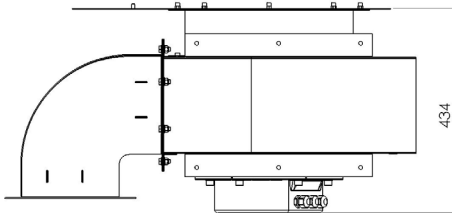
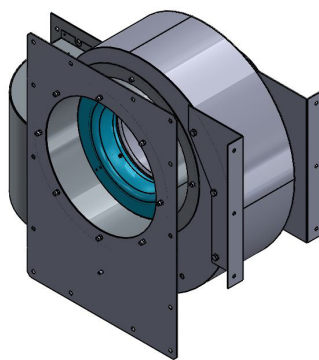
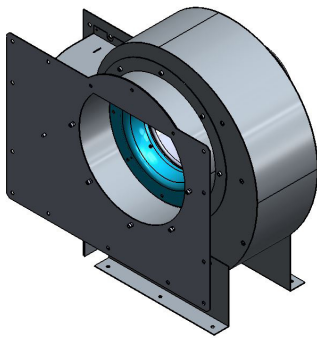

1.



Before upgrade
 A Munters MXT2800 dehumidifier equipped with the original fan

2.

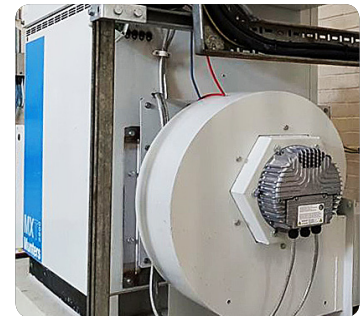

After upgrade
 Same unit now equipped with the new EC fan motor.

Australia Phone +61 2 8843 1580, serviceair@munters.com.au Austria Phone +43 1 6164298-0, service.dh@munters.at Belgium & Luxembourg Phone +32 2 240 6868, service.dh@muntersnv.be Brazil Phone +55 41 3317 5050, munters@com.br Canada Phone +1 905 858 5894, dhinfo@munters.com China Phone +86 10 8041 8000, serviceair@munters.cn Czech Republic Phone +420 775 569 657, servicecz@munters.de Denmark Phone +45 4495 3355, service.dh@munters.dk Finland Phone +358 40 186 3074, service.dh@munters.fi France Phone +33 1 3411 5757, service.dh@munters.fr Germany Phone +49 40 87 96 90-0, service.dh@munters.de India Phone +91 20 6681 8900, serviceair@munters.in Italy Phone +39 0183 521 377, service.dh@munters.it Japan Phone +81 3 5970 0021, serviceair@munters.jp Korea +82 2 761 8701, munters@munters.co.kr Mexico Phone +52 722 270 4029, servicedhm@munters.com Netherlands Phone +31 172 43 32 31, service@munters.nl Poland Phone +48 58 305 35 17, service.dh@munters.pl Singapore Phone +65 6744 6828, serviceair@munters.com.sg Spain & Portugal Phone +34 91 640 09 02, service.dh@munters.es Sweden & Norway Phone +46 8 626 6300, service.dh@munters.se Switzerland Phone +41 52 3438886, service.dh@munters.ch Thailand Phone +66 2 6422 6703, serviceair@munters.com.sg Turkey Phone +90 216 548 1444, serviceair@munters.com.tr UAE Phone +971 4880 9295, middle.east@munters.com United Kingdom & Ireland Phone +44 1480 432243, service.dh@munters.com.uk USA Phone +1 978 241 1100, dhservice@munters.com Vietnam Phone +84 8 3825 6838, vietnam@muntersasia.com

Your closest office: