

Installation Manual

Trio Poultry Controller



Trio

Poultry Controller

Ag/MIS/ImIT-2850-11/22 Rev 1.3
P/N: 117858



Trio Poultry Controller

Installation Manual

Rev 1.3, 10/2023

Product Software: Version 5.0.18

This manual for use and maintenance is an integral part of the apparatus together with the attached technical documentation.

This document is destined for the user of the apparatus: it may not be reproduced in whole or in part, committed to computer memory as a file or delivered to third parties without the prior authorization of the assembler of the system.

Munters reserves the right to effect modifications to the apparatus in accordance with technical and legal developments.

Index

| <i>Chapter</i> | | <i>page</i> |
|----------------|---|-------------|
| 1 | INTRODUCTION..... | 8 |
| 1.1 | Disclaimer..... | 8 |
| 1.2 | Introduction..... | 8 |
| 1.3 | Notes..... | 8 |
| 2 | BEFORE INSTALLING THE TRIO | 9 |
| 3 | PRECAUTIONS..... | 10 |
| 3.1 | Grounding..... | 10 |
| 3.2 | Filtering | 10 |
| 3.3 | Checking the Battery Level | 10 |
| 3.4 | Frequency Inverters..... | 11 |
| 4 | UNIT INSTALLATION | 12 |
| 4.1 | Preliminary Information | 12 |
| 4.1.1 | Safety Precautions | 12 |
| 4.1.1.1 | Grounding and Shielded Wiring..... | 12 |
| 4.1.1.2 | Installation and Electrical Connections | 13 |
| 4.1.2 | What Comes in the Package..... | 13 |
| 4.2 | Mounting the Unit..... | 13 |
| 4.2.1 | Knockouts..... | 13 |
| 4.2.2 | Hanging the Unit..... | 14 |
| 4.3 | Layout..... | 15 |
| 4.3.1 | Board Layout..... | 15 |
| 4.3.2 | External Device Specifications..... | 16 |
| 4.4 | Wiring Diagrams | 17 |
| 4.4.1 | High Voltage Relays | 18 |
| 4.4.2 | Alarms and Power | 20 |
| 4.4.3 | Internet Connection..... | 21 |
| 4.4.4 | Analog Output Devices | 22 |
| 4.4.5 | Digital Devices | 23 |
| 4.4.6 | Analog Input Devices | 24 |
| 4.4.6.1 | CO2 Sensor Wiring..... | 24 |
| 4.4.6.2 | Temperature Sensor Wiring..... | 26 |
| 4.4.6.3 | Humidity Sensor Wiring..... | 28 |
| 4.4.6.4 | Potentiometer Wiring | 29 |
| 4.4.6.5 | Ammonia Sensor Wiring..... | 30 |

| | | |
|----------|---|-----------|
| 4.4.6.6 | Light Sensor Wiring..... | 31 |
| 4.4.7 | Trio RPS..... | 32 |
| 4.4.8 | Bird Scale Card..... | 34 |
| 4.4.9 | Silo Wiring..... | 35 |
| 4.4.10 | RSU Wiring..... | 36 |
| 4.5 | Pressure Sensor Hoses..... | 37 |
| 4.6 | Key..... | 37 |
| 4.7 | Product Symbols..... | 38 |
| 5 | TRIOAIR..... | 39 |
| 5.1 | Trio Air Accounts..... | 39 |
| 5.2 | Pairing a Trio..... | 40 |
| 6 | SPECIFICATIONS..... | 45 |
| 7 | USING THE TRIO TOUCH SCREEN..... | 46 |
| 8 | MAPPING AND DEFINING THE INPUT OUTPUT DEVICES..... | 48 |
| 8.1 | Mapping Devices..... | 48 |
| 8.2 | Temperature Sensors..... | 52 |
| 8.2.1 | Defining the Temperature Sensors..... | 52 |
| 8.2.2 | Mapping the Temperature Sensors..... | 52 |
| 8.2.3 | Enabling a Weather Station..... | 53 |
| 8.3 | Ventilation Devices..... | 54 |
| 8.3.1 | Defining the Fans..... | 54 |
| 8.3.1.1 | On-Off Fans..... | 54 |
| 8.3.1.2 | 0 – 10 Volt Fans..... | 55 |
| 8.3.2 | Defining the Stir Fan..... | 56 |
| 8.3.2.1 | On Off Stir Fan..... | 56 |
| 8.3.2.2 | 0 – 10 Volt Stir Fan..... | 57 |
| 8.4 | Sensors..... | 58 |
| 8.4.1 | Defining the Ammonia Sensor..... | 58 |
| 8.4.2 | Defining the CO2 Sensor..... | 59 |
| 8.4.3 | Defining the Humidity Sensors..... | 60 |
| 8.4.4 | Defining the Water Meter Sensors..... | 61 |
| 8.4.5 | Defining the Gas Meter Sensors..... | 62 |
| 8.5 | Heating Devices..... | 63 |
| 8.5.1 | Defining the On/Off Heaters..... | 63 |
| 8.5.2 | Defining the Variable Heaters..... | 64 |
| 8.6 | Defining the Cooling Devices..... | 65 |
| 8.7 | Inlets, Tunnel Doors, Outlets..... | 66 |
| 8.7.1 | Mapping the Potentiometers..... | 66 |
| 8.7.2 | Defining the Inlets/Tunnel Doors..... | 67 |
| 8.7.2.1 | Potentiometer Calibration..... | 68 |

| | | |
|-----------|--|-----------|
| 8.7.2.2 | Calibrating the Inlets/Tunnel Door | 68 |
| 8.7.3 | Defining the Outlet | 70 |
| 8.8 | Defining the Same As Relays | 71 |
| 8.9 | Defining the Same As Analog Ports | 72 |
| 8.10 | Defining the Timer | 73 |
| 8.11 | Defining the Auxiliary Input | 74 |
| 8.12 | Lighting Devices..... | 75 |
| 8.12.1 | Defining the On/Off Lights..... | 75 |
| 8.12.2 | Defining the Variable Lights | 76 |
| 8.12.3 | Defining the Light Sensor | 77 |
| 8.13 | Feeding Devices | 78 |
| 8.13.1 | Defining the Auger Relays..... | 78 |
| 8.13.2 | Defining the Auger Active Sensors | 79 |
| 8.13.3 | Defining the Feeder Relays | 80 |
| 8.13.4 | Defining the Feeder Active Sensors..... | 81 |
| 8.14 | Defining the Silos | 82 |
| 8.14.1 | Mapping the Silo Scales | 82 |
| 8.14.2 | Configuring the Silo Scale | 84 |
| 8.15 | Defining the Bird Scales | 88 |
| 8.15.1 | Mapping the Bird Scales | 88 |
| 8.15.2 | Calibrating the Bird Scales..... | 90 |
| 8.15.3 | Testing the Bird Scale | 92 |
| 8.16 | Defining the RSU..... | 93 |
| 8.17 | Defining the Trio RPS..... | 93 |
| 8.17.1 | Define the Sensor | 93 |
| 8.17.2 | Static Pressure Calibration..... | 94 |
| 9 | APPENDIX A: EXTERNAL DEVICES (PREVIOUS VERSIONS)..... | 97 |
| 10 | APPENDIX B: SERVICE MANUAL | 99 |
| 10.1 | Maintenance | 99 |
| 10.2 | Trouble Shooting | 100 |
| 10.2.1 | Internet..... | 100 |
| 10.2.2 | Electronic Components | 101 |
| 10.3 | Spare Parts | 102 |
| 10.3.1 | Preliminary Information | 102 |
| 10.3.2 | Trio 20 Container Spare Parts..... | 103 |
| 10.3.3 | Trio 20 Door Card Spare Parts..... | 105 |
| 10.3.4 | Trio 20 Main Container Spare Parts..... | 107 |
| 10.3.5 | Additional Options..... | 110 |
| 10.3.6 | Cards | 111 |
| 10.3.6.1 | Door Cards | 111 |
| 10.3.6.2 | Main Container Cards..... | 114 |

| | | |
|-----------|---|------------|
| 11 | APPENDIX C: TRIO EXPANSION 10 | 116 |
| 11.1 | Expansion Layout | 116 |
| 11.2 | Expansion Wiring Diagrams | 117 |
| 11.2.1 | Trio to Trio Expansion Wiring | 117 |
| 11.2.2 | High Voltage Relays | 118 |
| 11.2.3 | Power | 119 |
| 11.3 | Trio / Trio Expansion Termination | 120 |
| 11.4 | Key | 121 |
| 11.5 | Product Symbols | 121 |
| 11.6 | Mapping Devices in Expansion | 122 |
| 11.7 | Expansion Specifications | 123 |
| 11.8 | Expansion Spare Parts | 123 |
| 11.8.1 | Preliminary Information | 124 |
| 11.8.2 | Trio 10 Expansion Container Spare Parts | 124 |
| 11.8.3 | Trio 10 Expansion Main Container Spare Parts | 126 |
| 11.8.4 | Main Container Card Spare Parts | 127 |
| 12 | APPENDIX D: TRIO CELL MODEM INSTALLATION | 128 |
| 12.1 | Prerequisites | 128 |
| 12.1.1 | Supported Devices | 128 |
| 12.1.2 | Required Software | 128 |
| 12.1.3 | Internet Access | 128 |
| 12.2 | Installation | 129 |
| 12.2.1 | Physical Installation | 129 |
| 12.2.1.1 | Modem and SIM Card | 129 |
| 12.2.1.2 | Drilling | 132 |
| 12.2.2 | Configuration | 134 |
| 13 | APPENDIX E: PANEL MOUNT INSTALLATION | 137 |
| 13.1 | Trio Panel Mount Installation | 137 |
| 13.1.1 | Precautions | 137 |
| 13.1.2 | Panels | 138 |
| 13.1.3 | Panel Dimensions | 139 |
| 13.1.4 | Mounting the Panels | 140 |
| 13.1.5 | Panel Cables | 141 |
| 13.1.6 | Powering and Alarms | 142 |
| 13.1.7 | Grounding | 142 |
| 13.2 | Trio Expansion Panel Mount Installation | 143 |
| 13.2.1 | Precautions | 143 |
| 13.2.2 | Panels | 144 |
| 13.2.3 | Panel Dimensions | 145 |
| 13.2.4 | Panel to Panel Expansion Wiring | 146 |

| | | |
|--------|--|------------|
| 13.2.5 | Power | 147 |
| 13.2.6 | Trio Panel / Trio Panel Expansion Termination..... | 148 |
| 14 | WARRANTY | 149 |

1 Introduction

1.1 Disclaimer

Munters reserves the right to make alterations to specifications, quantities, dimensions etc. for production or other reasons, subsequent to publication. The information contained herein has been prepared by qualified experts within Munters. While we believe the information is accurate and complete, we make no warranty or representation for any particular purposes. The information is offered in good faith and with the understanding that any use of the units or accessories in breach of the directions and warnings in this document is at the sole discretion and risk of the user.

1.2 Introduction

Congratulations on your excellent choice of purchasing a Trio Poultry Controller!

In order to realize the full benefit from this product it is important that it is installed, commissioned and operated correctly. Before installation or using the controller, this manual should be studied carefully. It is also recommended that it is kept safely for future reference. The manual is intended as a reference for installation, commissioning and day-to-day operation of the Munters Controllers.

1.3 Notes

Date of release: Jan 2020

Munters cannot guarantee to inform users about the changes or to distribute new manuals to them.

All rights reserved. No part of this manual may be reproduced in any manner whatsoever without the expressed written permission of Munters. The contents of this manual are subject to change without notice.

2 Before Installing the Trio

- Munters strongly recommends that only panel mount controllers should be installed directly in an electrical closet.
- If this unit is installed in an electrical closet, ensure that no contactors are in that closet. Placing this unit in proximity to contactors results in severe signal interference.
- Review the guidelines given in the Precautions and Safety Precautions sections. These are vital to ensuring both personal safety and proper controller functioning.

3 Precautions

CAUTION Protection provided by the equipment can be impaired if the equipment is used in a manner not specified by the manufacturer!

CAUTION There is a risk of explosion if the lithium battery is replaced with an incorrect type. Replace the battery using the same type and manufacturer only.

- Grounding
- Filtering
- Checking the Battery Level
- Frequency Inverters

3.1 Grounding

- Always connect temperature and sensor shields to earth ground. Avoid mixing high voltage wiring with sensor and low voltage wiring.
- Keep the controller as far as possible from heavy contactor boxes and other sources of electrical interference.
- Do not connect communication wire shields, which go from one house to another at both ends. Connect them at one end only. Connection at both ends can cause ground loop currents to flow, which reduces reliability.
- The COM connection for communications is not the shield wire. The COM, RX and TX wires must connect to each other at all controllers.

3.2 Filtering

If this installation includes a power inverter to drive variable speed fans, install an EMI filter in front of the inverter, according to the specifications provided by the inverter manufacturer. Refer to the inverter documentation.

3.3 Checking the Battery Level

Check the battery once a year. The output must be 2.7 volts (minimum). Authorized personnel only must replace the battery if the output is below the minimum required level or every five years.

3.4 Frequency Inverters

Frequency inverters can cause severe electrical and electromagnetic interference. Therefore, when employing a frequency inverter, it is critical that you carefully follow the manufacturer's installation instructions.

In particular verify:

- That the cable shielding between the inverter and any motor meets industry standards
- Proper grounding of the inverter's chassis and motor power cable
- Proper grounding of low voltage cable shield wire
- That the controller and inverter cables are kept in separate conduits or wire bundles

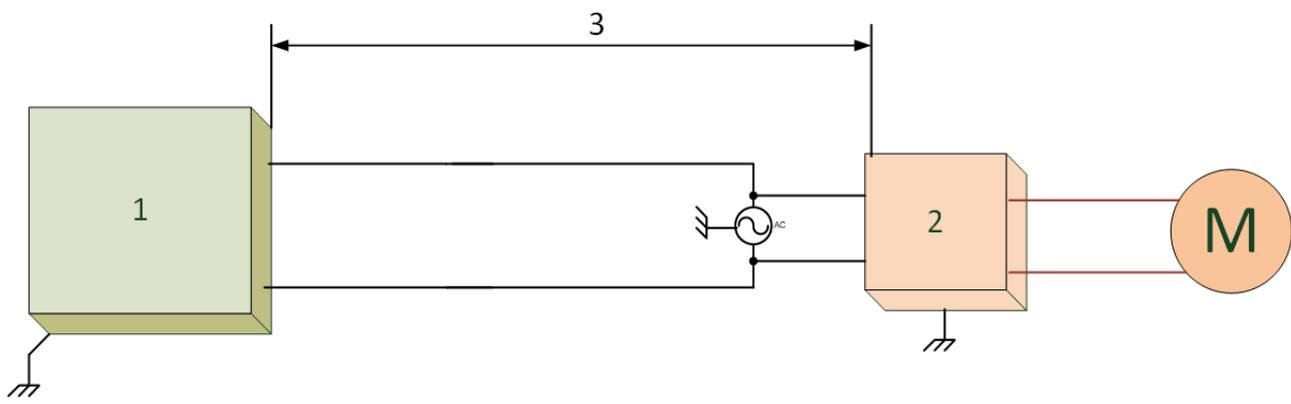

1. Controller

2. Inverter

3. Place the controller at least five meters from the inverter.

4 Unit Installation

The following sections detail how to mount and wire the Trio.

NOTE Munters recommends that a trained technician perform the following operations.

- Preliminary Information
- Mounting the Unit
- Layout
- Wiring Diagrams
- Pressure Sensor Hoses
- Key
- Product Symbols

4.1 Preliminary Information

- Safety Precautions
- What Comes in the Package

4.1.1 SAFETY PRECAUTIONS

CAUTION These units must be installed by an authorized electrician. Disconnect the power to avoid electrical shock and damage.

NOTE Installation Category (Over voltage Category) II

- The power supply to the controller should be protected by 1 amp circuit breaker.
- All electrical connections should comply with the National Electrical code (NEC).

4.1.1.1 Grounding and Shielded Wiring

- **From the ground terminal, run a heavy wire directly to the ground rod. If necessary, run a heavy ground wire to the electrical service grounding system rather than directly to the ground rod.**
- Do not use light wires for these ground connections. They must carry heavy lightning currents, sometimes exceeding thousands of amperes. Certainly, do not use the shielding of sensor and low voltage wiring for this purpose.
- When splicing sensors to longer wires, ensure that the splice is **waterproof**. Use adhesive lined heat shrink (marine grade) to make waterproof connections.
- Every low power device (digital, analog, or communication) must have a shield cable connected to the unit ground strip.

4.1.1.2 Installation and Electrical Connections

- Install any Munters controller at least three feet (one meter) away from interference sources such as high voltage wiring to motors, variable speed devices, light dimmers, or contactors.
- Install electronic controls in a separate ventilated control room that is protected from extreme temperatures and dirty environments. Place the controls so that the operators can conveniently use the control and read indicators and displays.
- Keep low voltage wires separate from high voltage wires.
- Use shielded wiring for low level signals. For buried wiring (building to building runs) use high grade jell filled cables that are impervious to moisture.
- Seal cable entry points and control boxes to prevent contamination and corrosion. If you use silicon sealant with acetic acid cure, keep the control open and ventilated until cured. Otherwise, the acetic acid will attack the metal parts, including circuitry.

4.1.2 WHAT COMES IN THE PACKAGE

- One Trio unit
- One hanging bracket
- Two screws

4.2 Mounting the Unit

- Knockouts
- Hanging the Unit

4.2.1 KNOCKOUTS

1. Using the supplied clips and screws, mount the Trio.
2. On the bottom the Trio are knockouts used to route the low and high voltage cables.

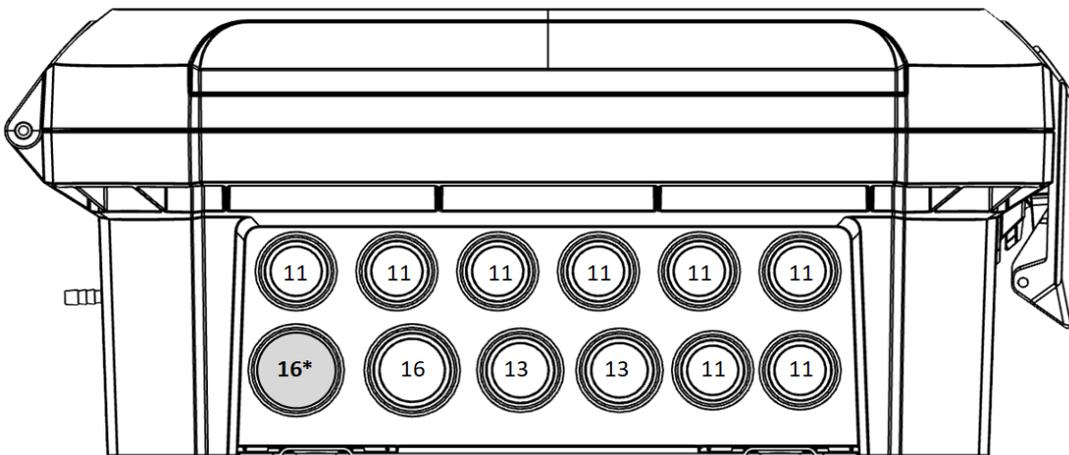

Figure 1: Trio Knockouts and PG Size

- Using a screwdriver and a hammer, gently apply pressure to the knockouts.
- Only open up the holes that you require.

- Munters recommends removing the knockouts before mounting the unit.
- 16*: Use this knockout for the Ethernet cable.

3. Place the required cables through the cable holders at the bottom of the unit.

CAUTION Run low voltage cables through one knockout and high voltage relay cables through a separate knockout. Do not place them in the same knockout!

4. Close the Trio enclosure lid carefully and tightly. Use RTV silicon or equivalent sealant to seal the cable holders.

CAUTION Munters strongly recommends that you seal all entry spots with RTV silicon. Failure to do so can lead to damage to the unit.

5. After installation is completed, operate the Trio for a few hours and re- check for proper operation.

4.2.2 HANGING THE UNIT

1. Attach the bracket to the wall (customer supplies the screws).

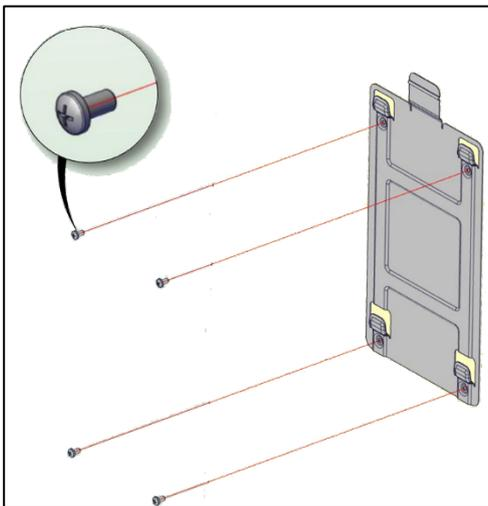

2. Hang the Trio on the bracket.

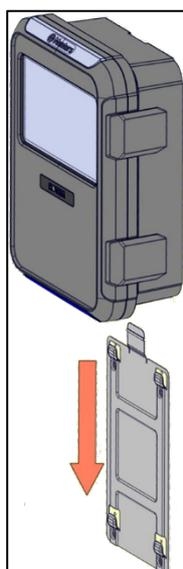

3. Secure the unit to the wall using the two screws provided (optional).

4.3 Layout

- Board Layout
- External Device Specifications

4.3.1 BOARD LAYOUT

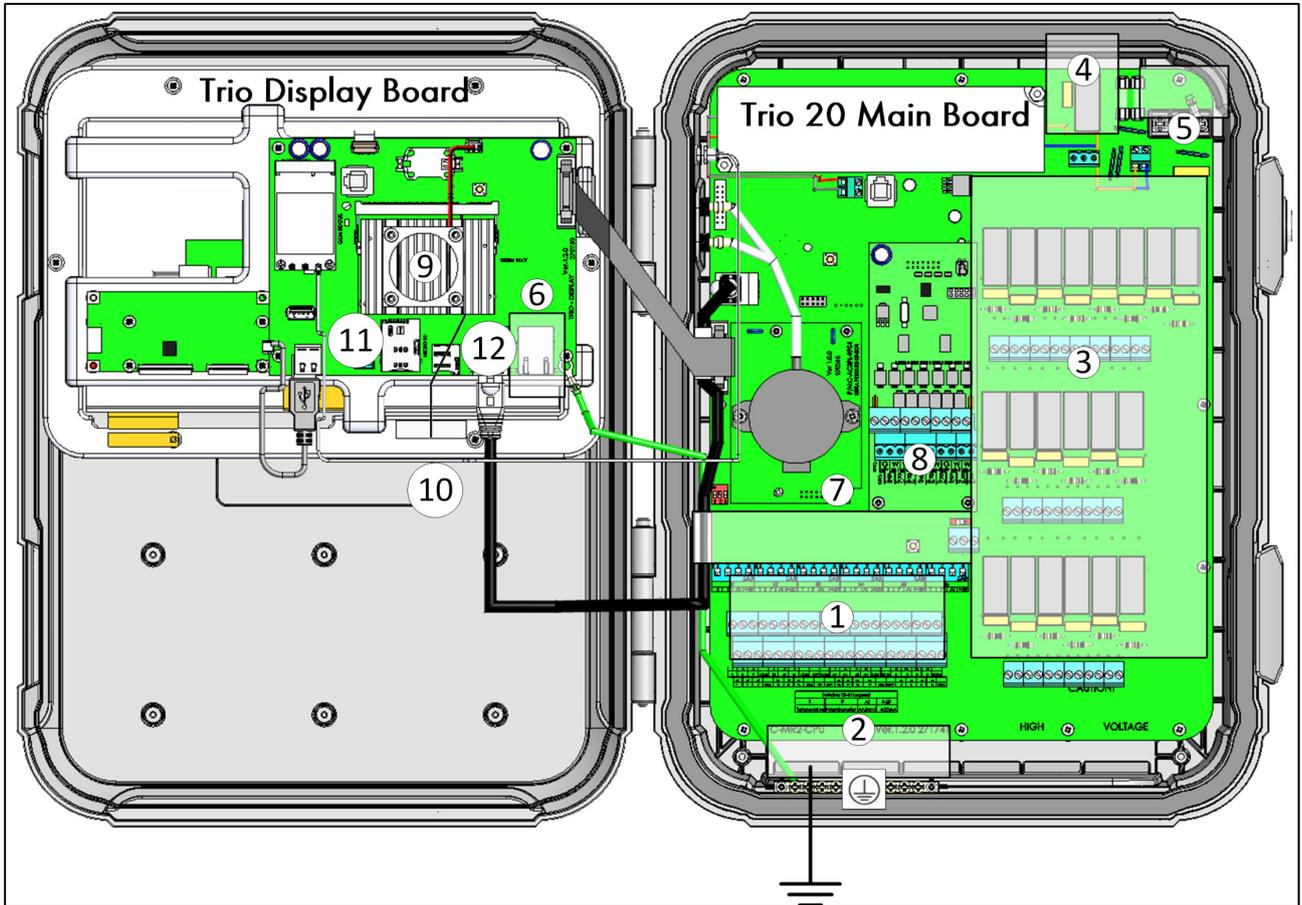

Figure 2: Board layout

| | | | |
|---|----------------------|----|------------------|
| 1 | Analog/digital ports | 7 | Dipswitches |
| 2 | Ground strip | 8 | Trio Scale Card |
| 3 | 20 relays | 9 | Heat Sink |
| 4 | Alarm relay | 10 | Wireless antenna |
| 5 | Power ports | 11 | SIM card port |
| 6 | Ethernet port | 12 | SD card port |

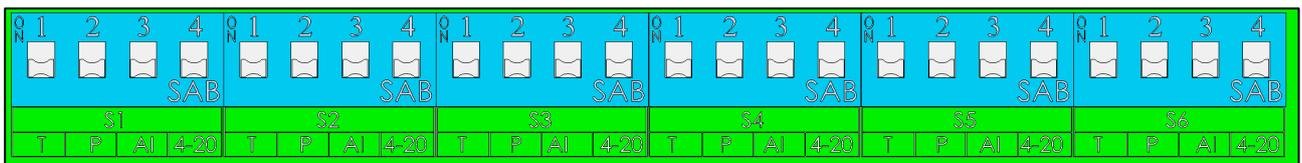

Figure 3: Dipswitches, expanded

- One dipswitch only in each set is raised.
- Only raise a dipswitch if a device is wired to an S port.

4.3.2 EXTERNAL DEVICE SPECIFICATIONS

Table 1: Summary

| I/O type | Qty |
|---------------------|-----|
| Analogue Output | 8 |
| Analogue Input | 6 |
| Digital Input | 8 |
| Temperature Sensors | 12 |
| Total | 34 |

Table 2: Output Devices

| Device type | Maximum Number of Devices | Number of Relay Devices | Number of Analog Devices |
|-----------------------|---------------------------|-------------------------|--------------------------|
| Cooling | 2 | 2 | N/A |
| Heaters | 6 | 6 | 6 |
| Inlets | 2 | 2 | 2 |
| Outlets | 1 | N/A | 1 |
| Tunnel Doors/Curtains | 2 | 2 | 2 |
| Fans Exhaust/Tunnel | 20 | 20 | 8 |
| Stir Fan | 1 | 1 | 1 |
| Lights | 4 | 4 | 4 |
| Timer | 5 | 5 | N/A |
| Auger | 2 | 2 | N/A |
| Feeder | 4 | 4 | N/A |
| Lighting | 4 | 4 | N/A |
| As Relay | 30 | 30 | N/A |
| As Analog Out | 8 | NA | 8 |
| Alarm | 1 | 1 | N/A |

Table 3: Sensors

| Device type | Analog Sensors | Digital Sensors |
|-----------------------------|----------------|-----------------|
| Temperature Sensors | 12 | N/A |
| Humidity Sensors | 2 | N/A |
| Outside Humidity Sensor | 1 | N/A |
| CO2 Sensors | 1 | N/A |
| Ammonia Sensors | 1 | N/A |
| Pressure Sensors | 2 | N/A |
| Potentiometers | 4 | N/A |
| Bird Weighing | 4 | N/A |
| Silo Weighing | 2 | N/A |
| Lux Meter (light intensity) | 1 | N/A |
| Water Meters | N/A | 4 |
| Gas Meters | N/A | 3 |
| Aux. Input | N/A | 4 |
| Auger Sensor | N/A | 2 |
| Feeder Line Sensor | N/A | 4 |

NOTE Refer to Appendix A: External Devices (Previous Versions), page 97 to view details on the input/output capacity of previous versions.

4.4 Wiring Diagrams

- High Voltage Relays
- Alarms and Power
- Internet Connection
- Analog Output Devices
- Digital Devices
- Analog Input Devices
- Trio RPS
- Bird Scale Card
- Silo Wiring
- RSU Wiring

4.4.1 HIGH VOLTAGE RELAYS

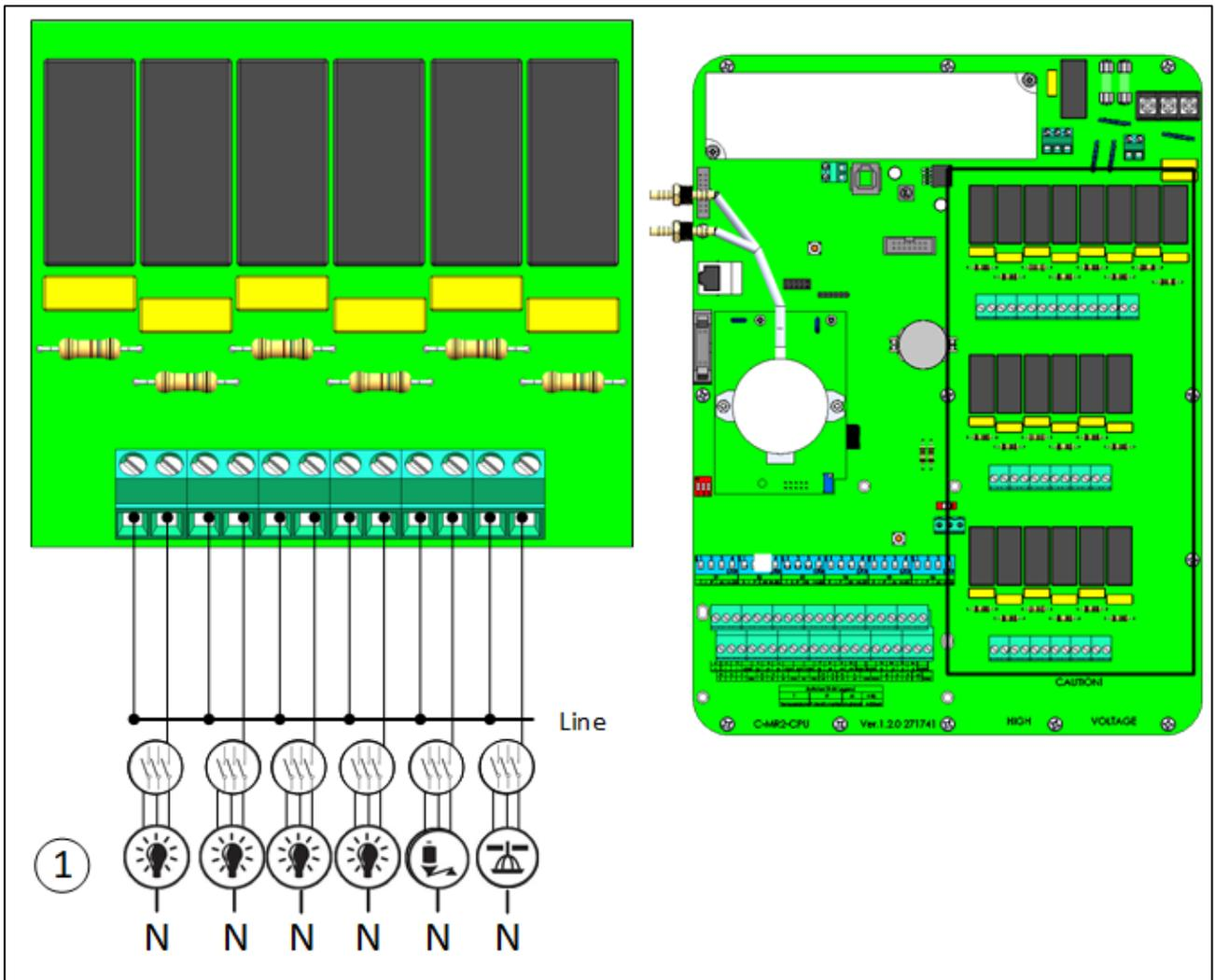

Figure 4: High voltage devices (examples)

| | |
|---|--------------------|
| 1 | Example of devices |
|---|--------------------|

NOTE The relays control motors and heating devices via contactors, not directly.

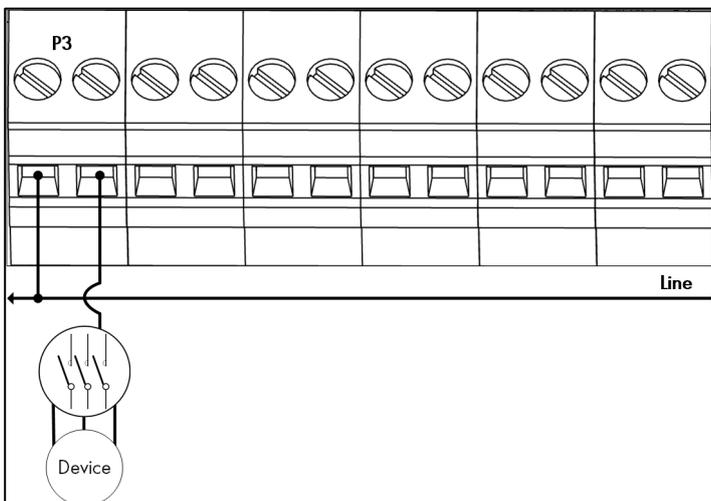

Figure 5: Relay wiring detailed view

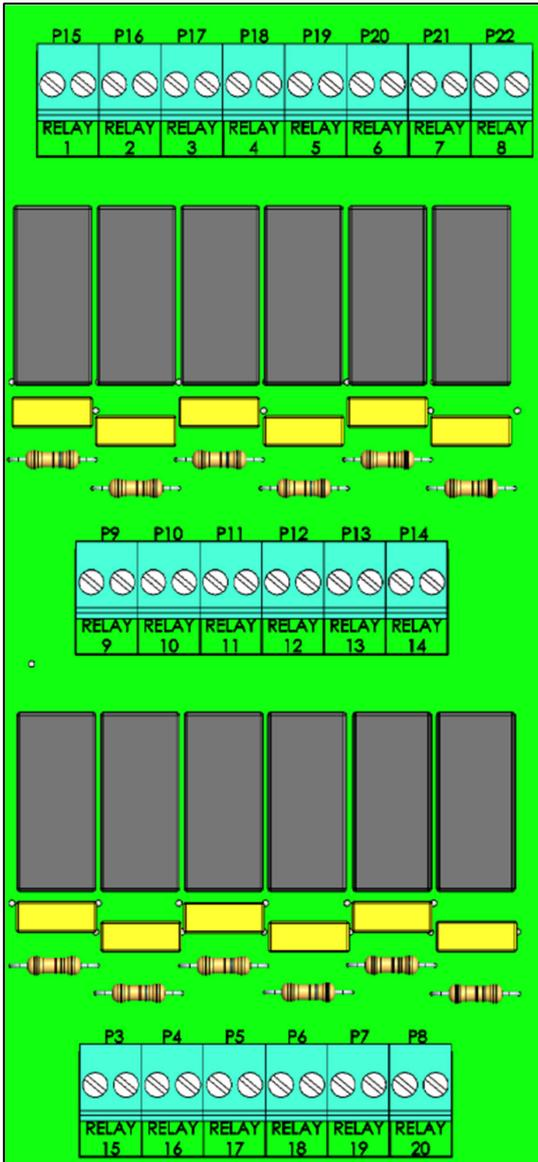

Figure 6: Relay and port numbering

4.4.2 ALARMS AND POWER

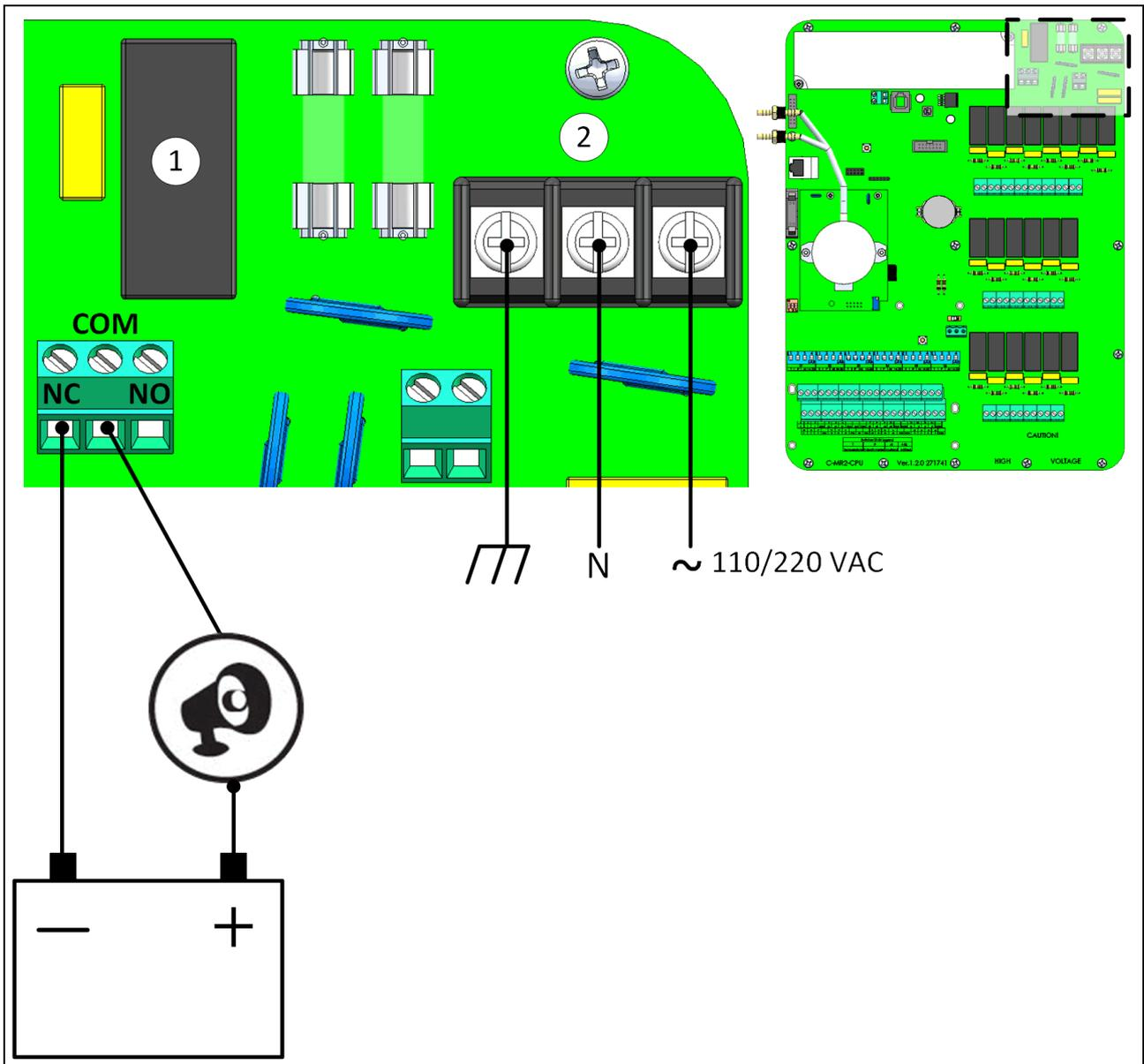

Figure 7: Alarm relay and power ports

| | |
|---|-------------|
| 1 | Alarm relay |
| 2 | Power ports |

- Connect the light or siren device to the alarm relay.

4.4.3 INTERNET CONNECTION

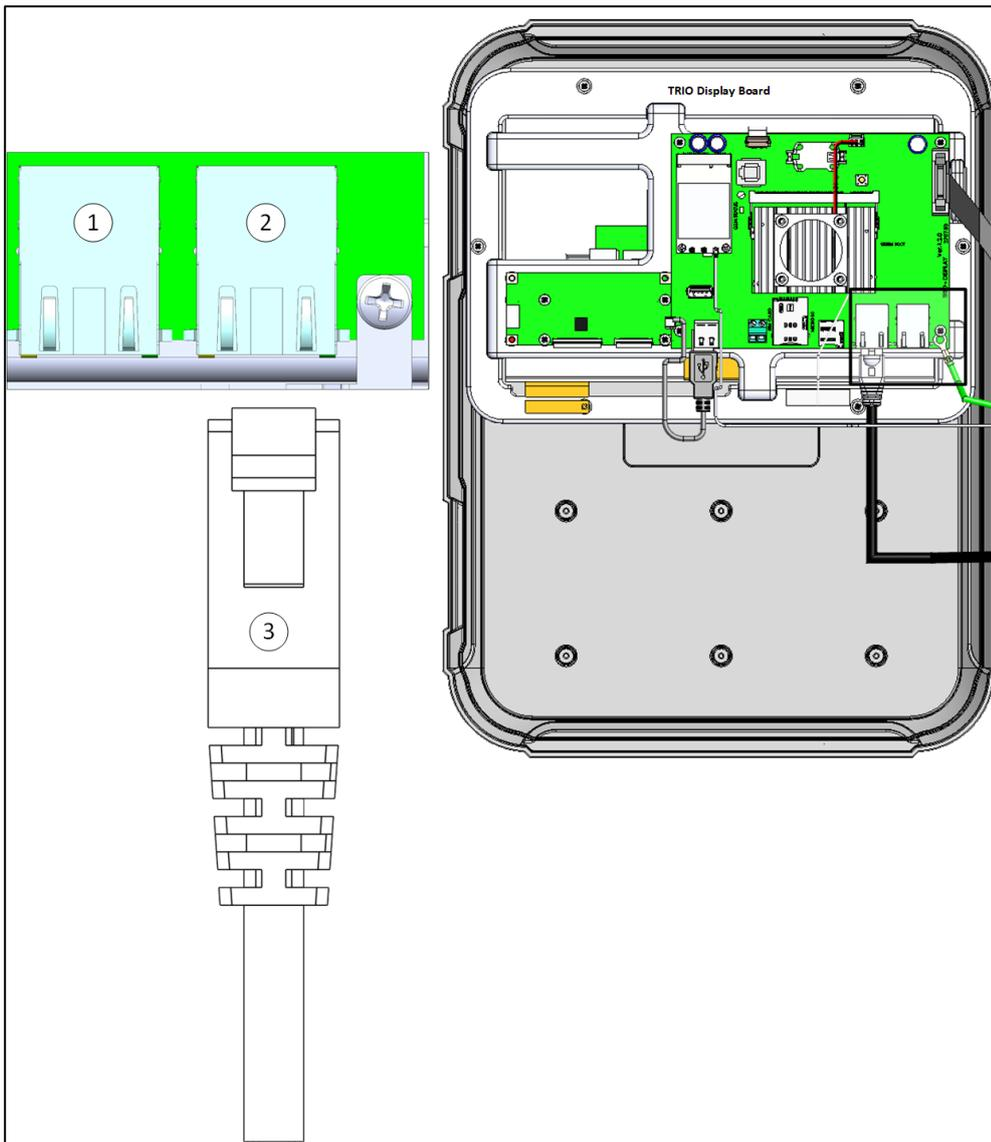

Figure 8: Ethernet port

CAUTION Connect the internet cable to port 2. Do not connect the cable to port 1.

| | |
|---|--------------------------------------|
| 1 | Internal port (do not use this port) |
| 2 | Ethernet port |
| 3 | RJ-45 cable |

4.4.4 ANALOG OUTPUT DEVICES

Trio supports analog control over a variety of devices.

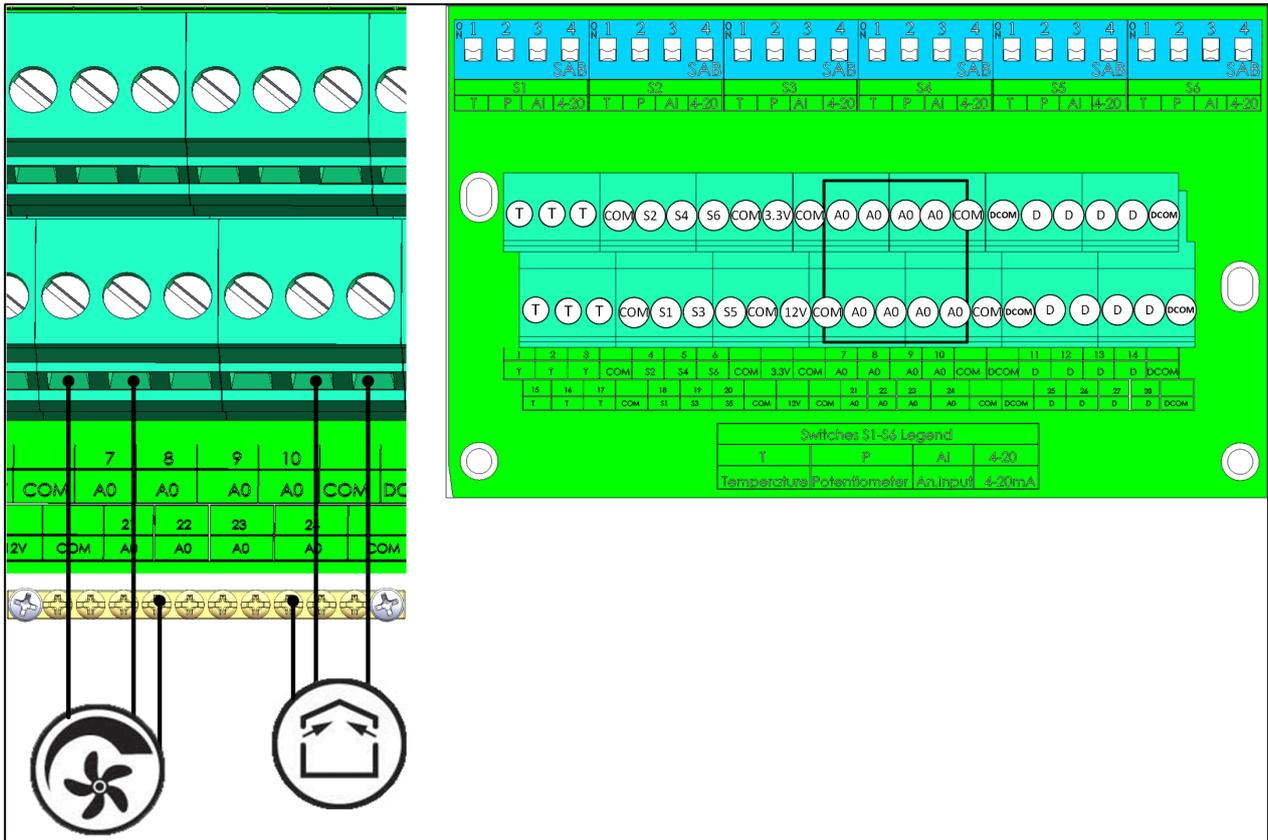

Figure 9: Analog Output devices (examples)

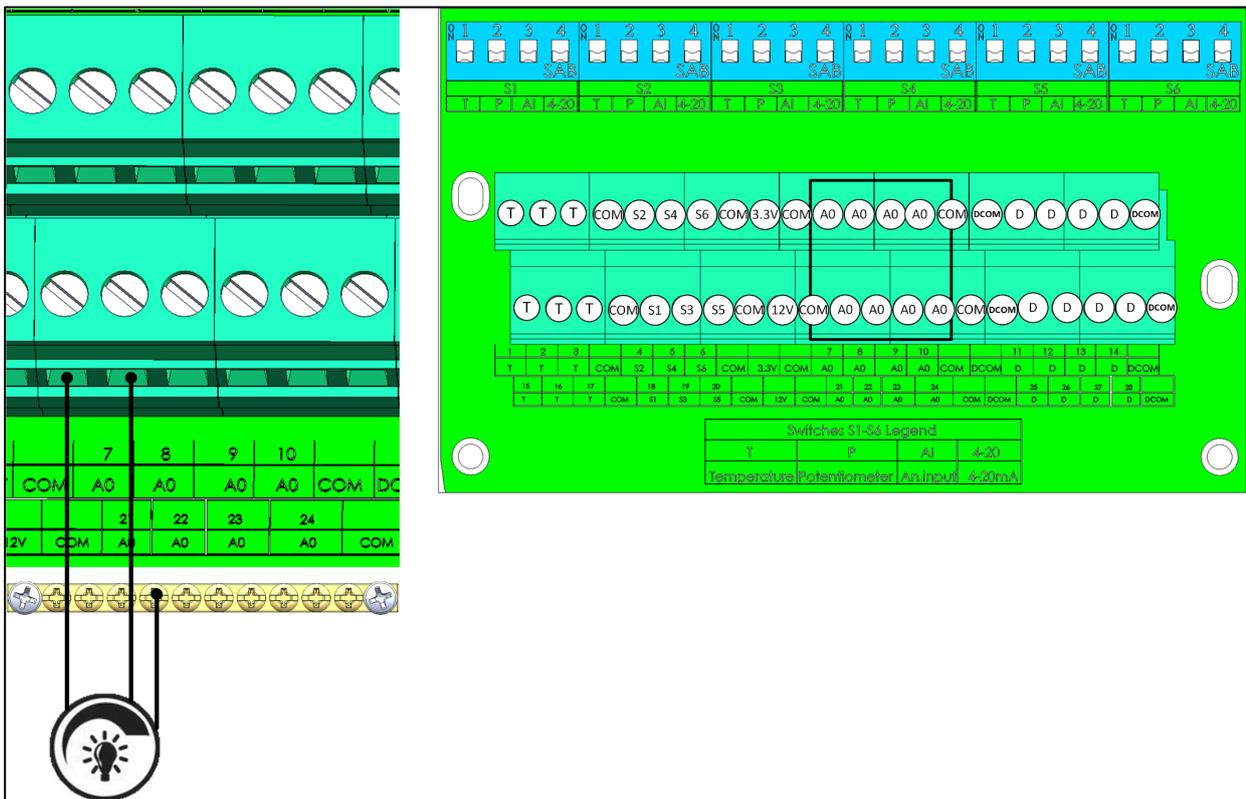

Figure 10: Light Dimmer devices

Connect analog output devices to an AO and a COM port. Ground these devices!

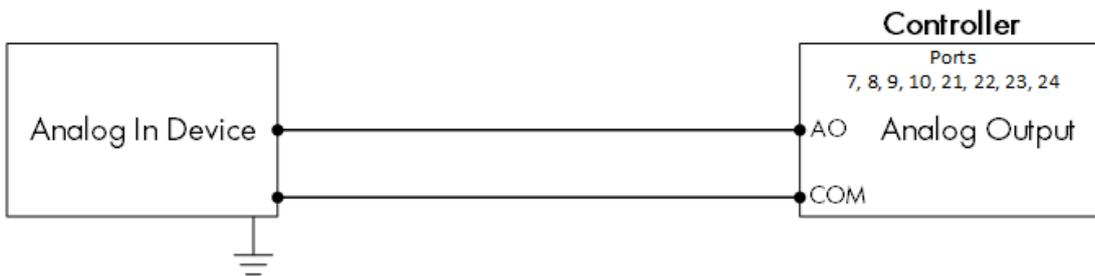

Figure 11: Analog Device Wiring Schematic

4.4.5 DIGITAL DEVICES

Trio supports water meters and auxiliary inputs.

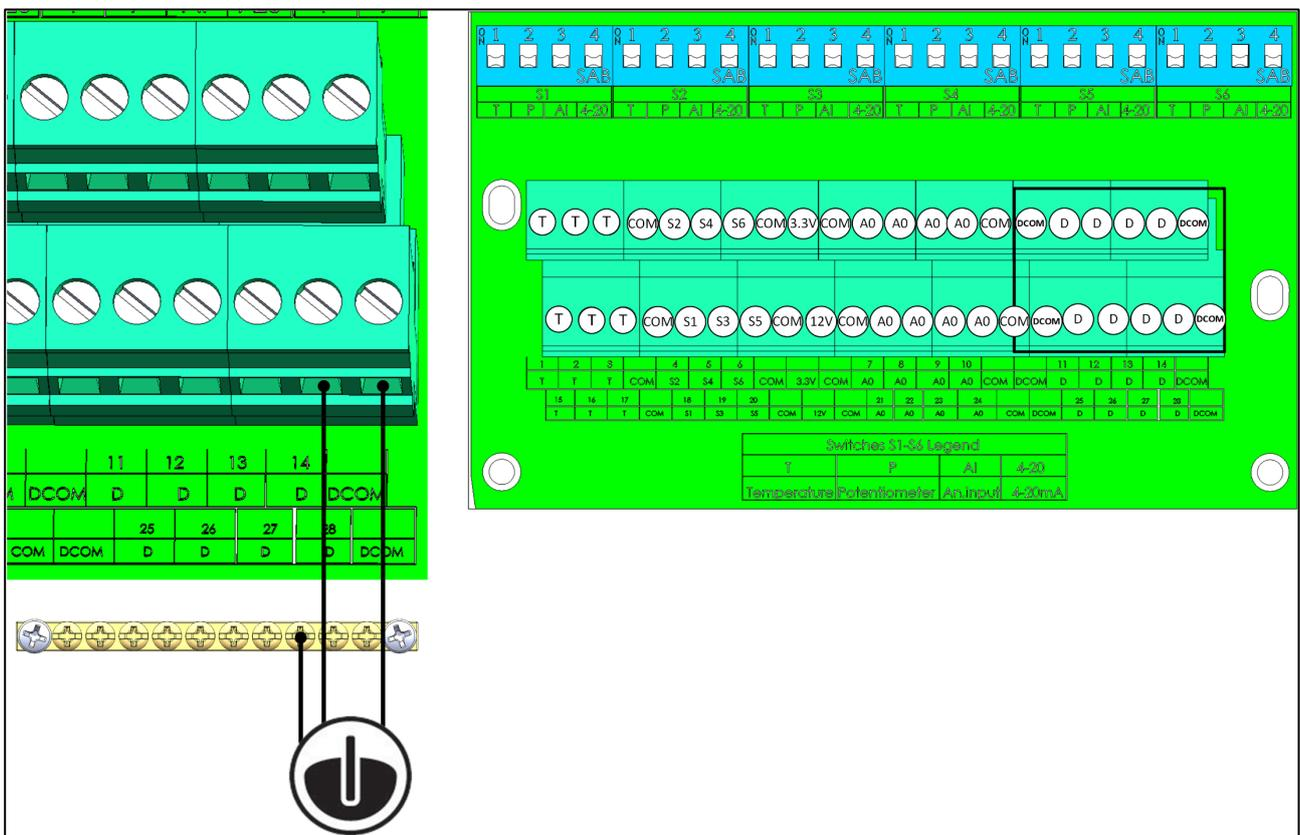

Figure 12: Digital Input devices (examples)

- Connect digital devices to a D port and a DCOM port.

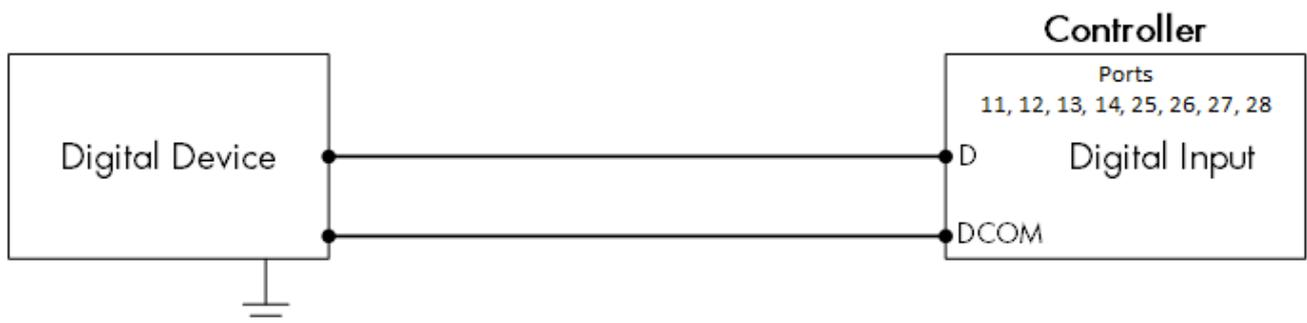

Figure 13: Digital Device Wiring Schematic

4.4.6 ANALOG INPUT DEVICES

- CO2 Sensor Wiring
- Temperature Sensor Wiring
- Humidity Sensor Wiring
- Potentiometer Wiring
- Ammonia Sensor Wiring
- Light Sensor Wiring

4.4.6.1 CO2 Sensor Wiring

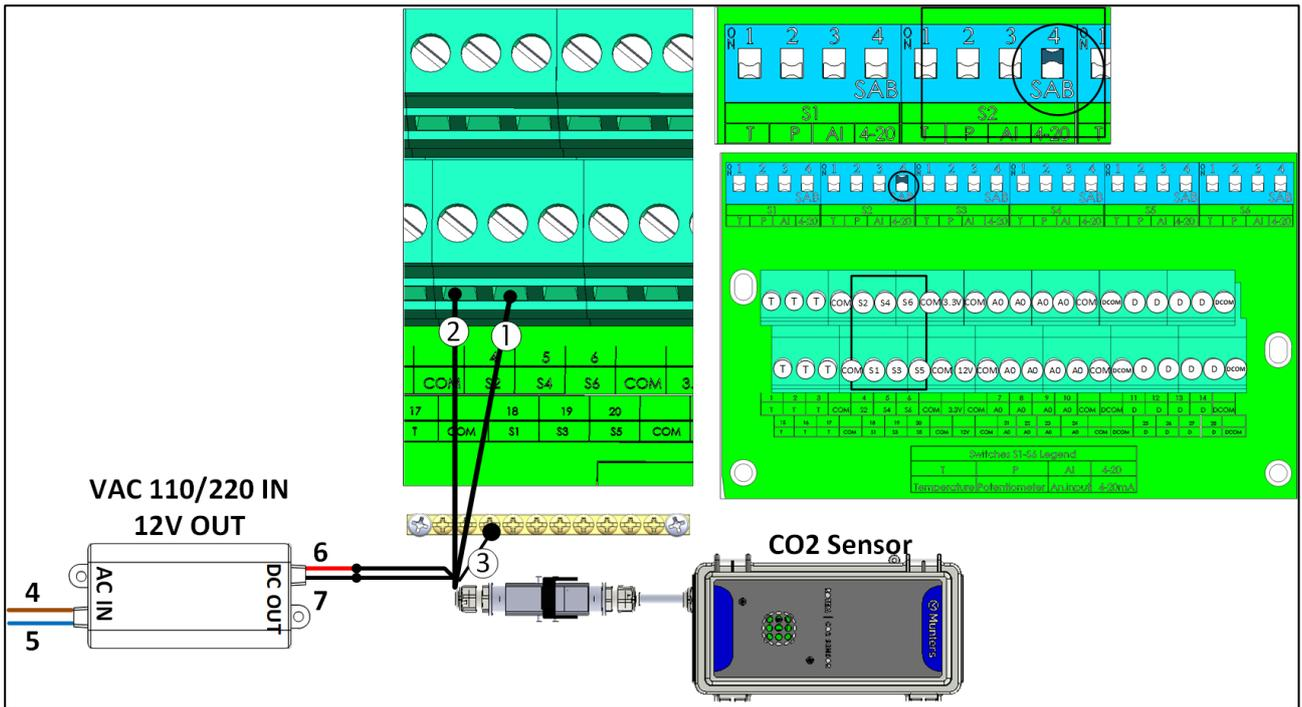

Figure 14: CO2 Sensor Wiring

| Number | Function |
|--------|--------------------|
| 1 | S port |
| 2 | COM port |
| 3 | Shield wire |
| 4 | Brown wire: phase |
| 5 | Blue wire: neutral |
| 6 | Red wire: +12VDC |
| 7 | Black wire: -12VDC |

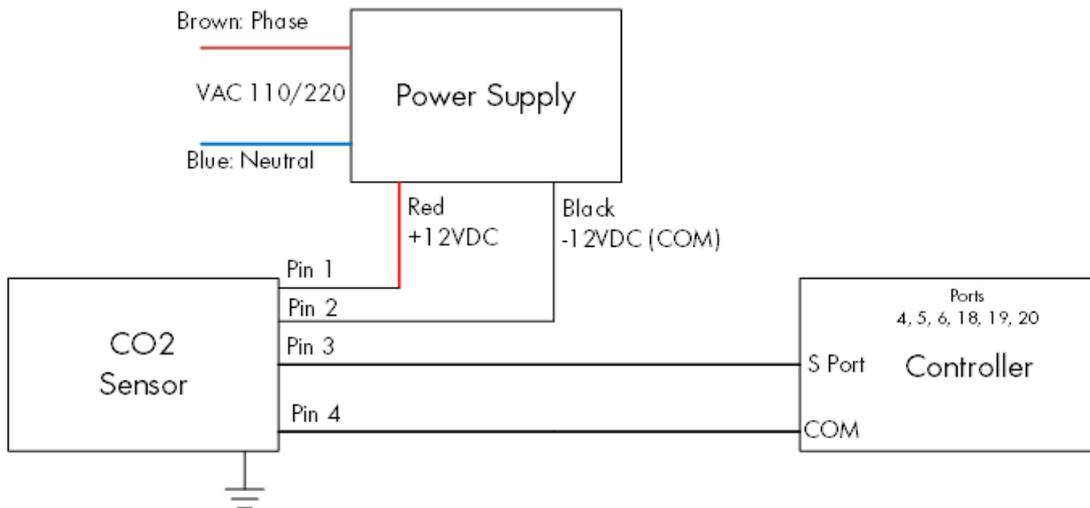

Figure 15: CO2 Sensor Wiring Schematic

- Connect the CO2 device to:
 - Controller:
 - S port. In the corresponding dipswitch, raise dipswitch 4 (4-20 mA).
 - COM port
 - Power supply
 - +12V
 - -12V

4.4.6.2 Temperature Sensor Wiring

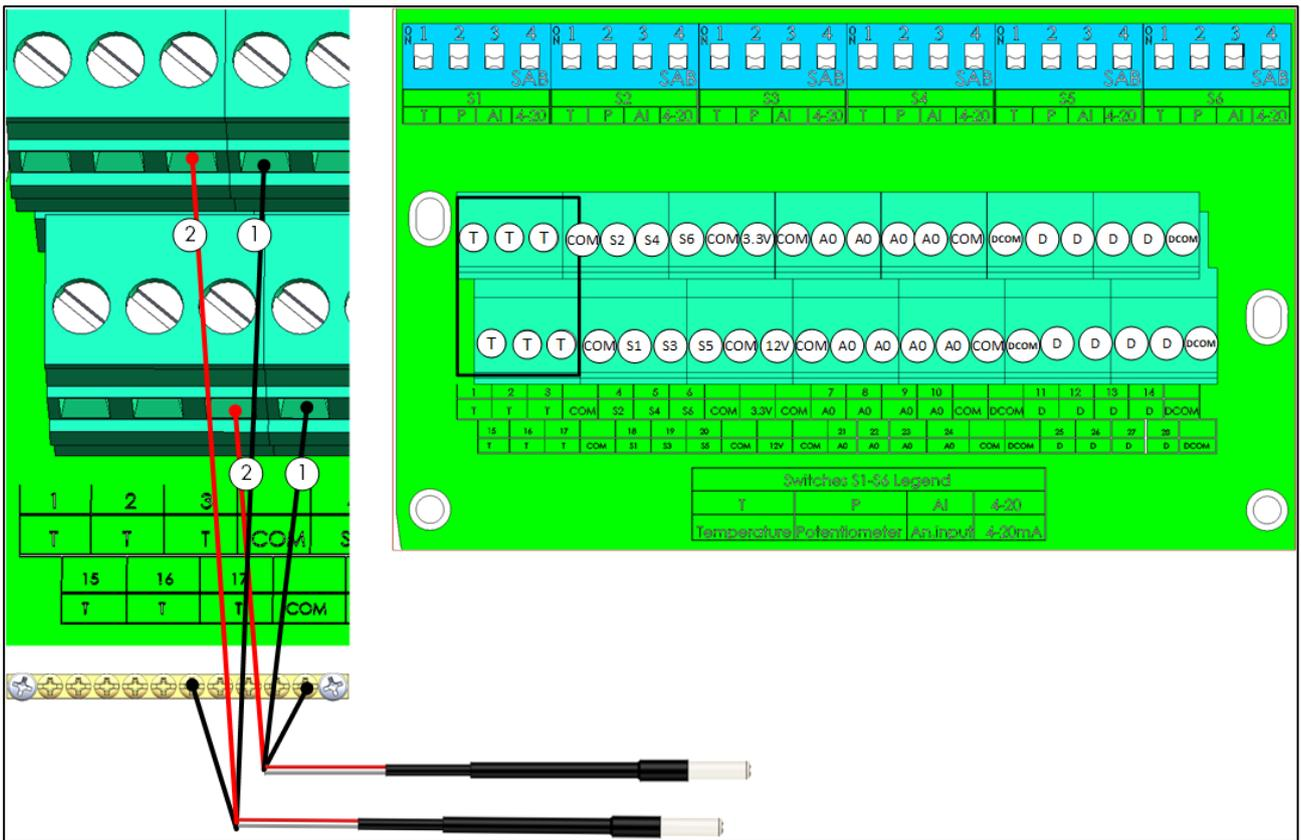

Figure 16: RTS Wiring

| Number | Function |
|--------|-----------------------|
| 1 | COM port (black wire) |
| 2 | T port (red wire) |

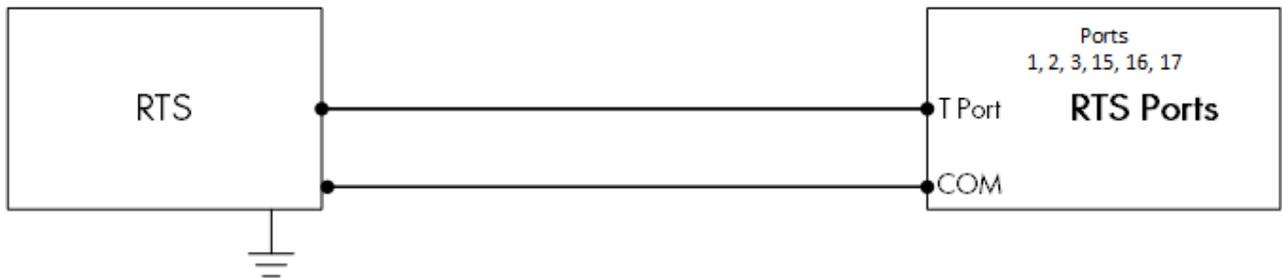

Figure 17: RTS Wiring Schematic

- Connect each RTS sensor to a:
 - T port
 - COM port
 - Grounding strip!

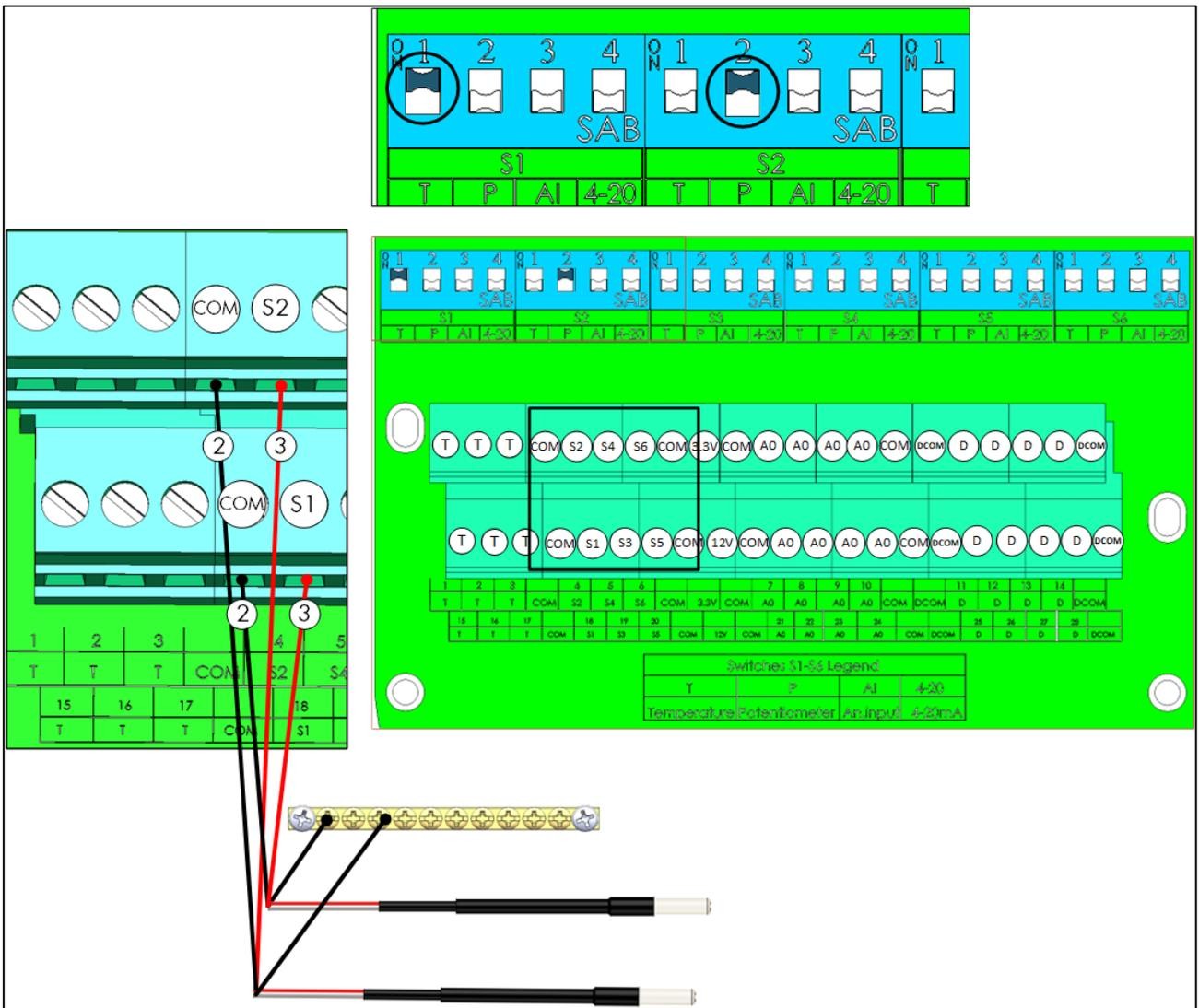

Figure 18: RTS S Port Wiring

| Number | Function |
|--------|-----------------------|
| 2 | COM port (black wire) |
| 3 | S port (red wire) |

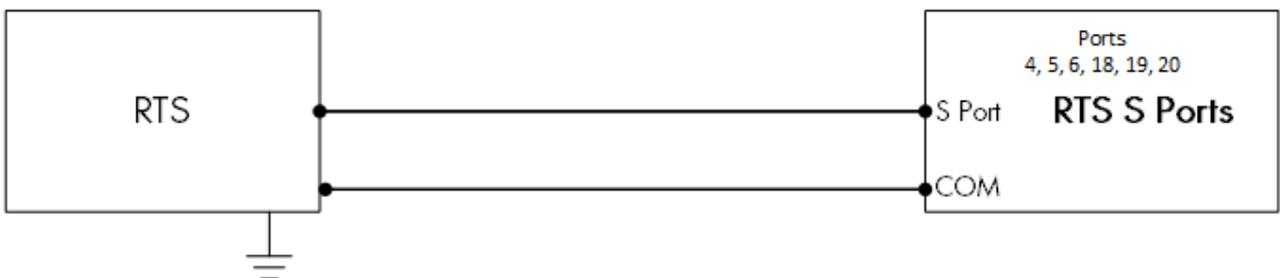

Figure 19: RTS S Port Wiring Schematic

- Connect each RTS sensor to a:
 - S port. In the corresponding dipswitch, raise dipswitch 1 (temp)
 - COM port
 - Grounding strip!

4.4.6.3 Humidity Sensor Wiring

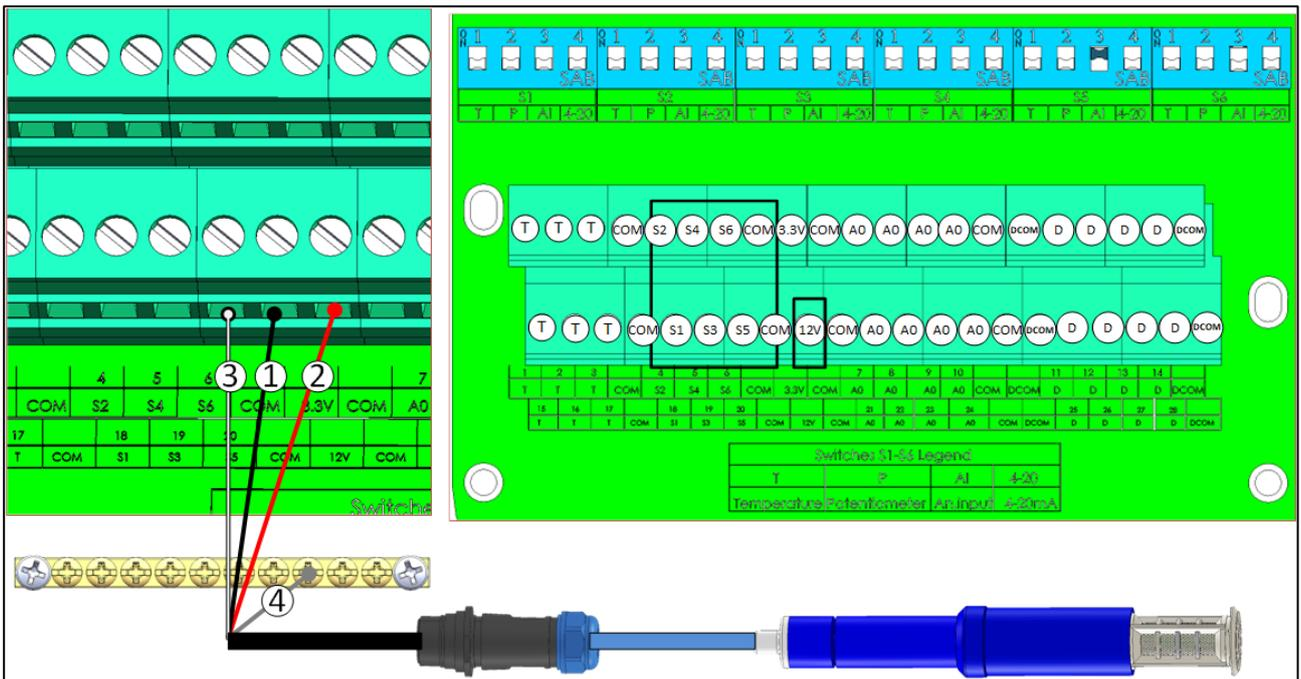

Figure 20: RHS+ Wiring

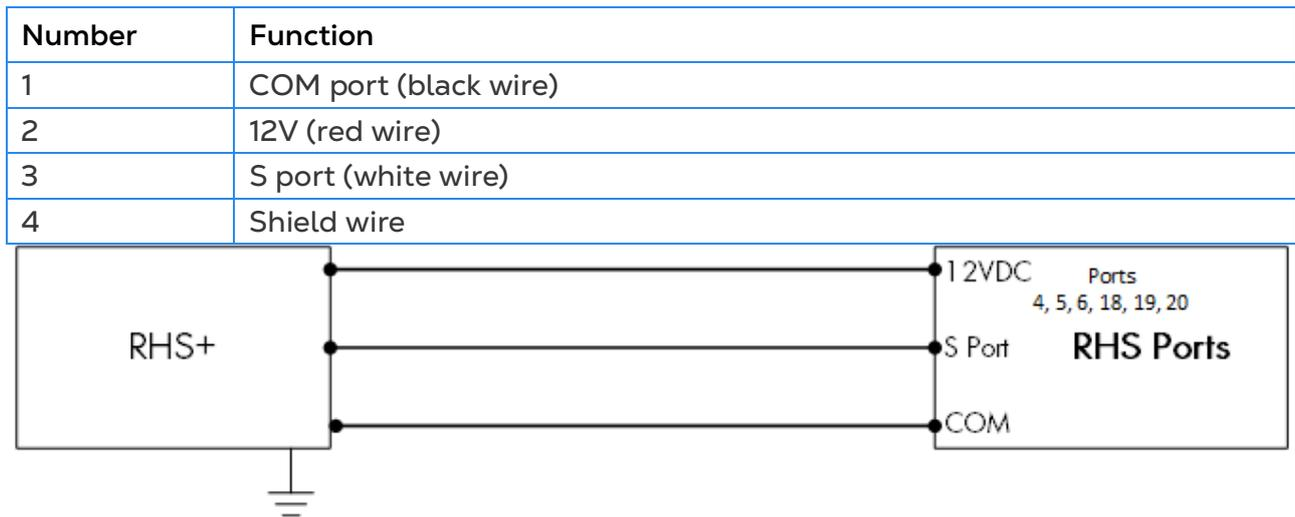

Figure 21: RHS+ Sensor Wiring Schematic

- Connect each RHS+ sensor to a:
 - S port. In the corresponding dipswitch, raise dipswitch 3 (analog input).
 - COM port.
 - 12VDC port.
 - Grounding strip!

4.4.6.4 Potentiometer Wiring

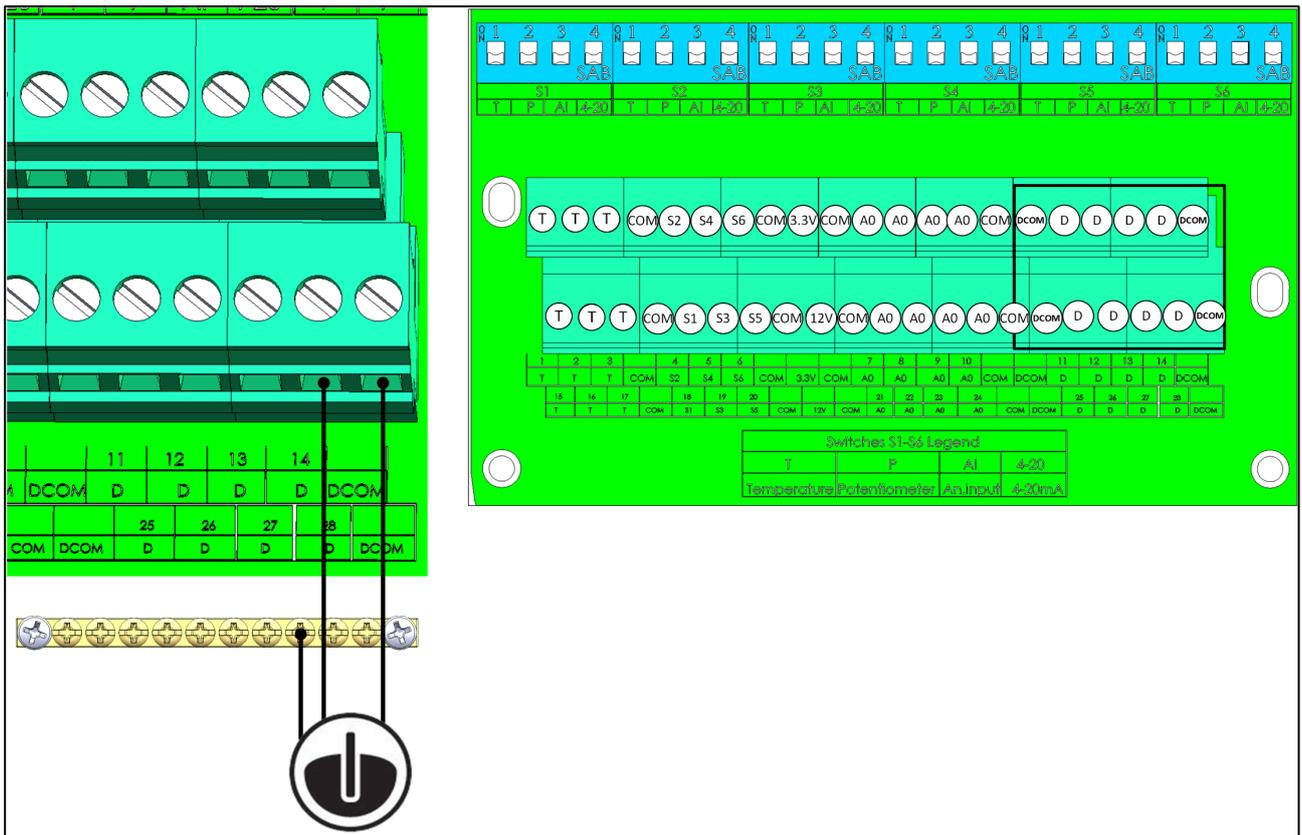

Figure 22: Potentiometer Wiring

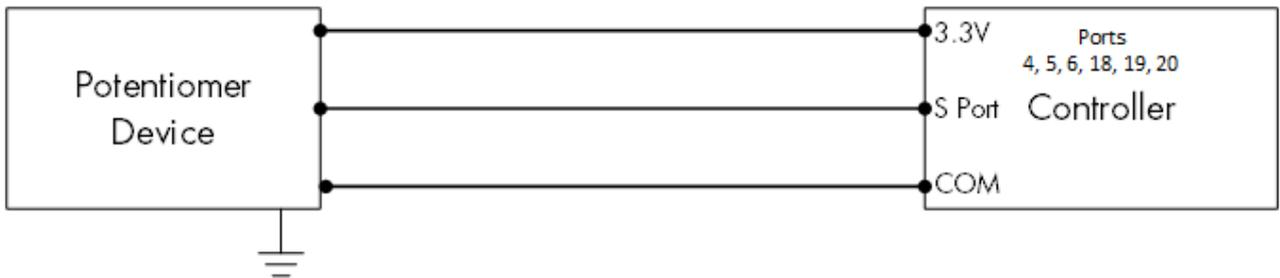

Figure 23: Potentiometer Wiring Schematic

- Connect each potentiometer to a:
 - S port. In the corresponding dipswitch, raise dipswitch 2 (potentiometer).
 - COM port.
 - 3.3V port.

4.4.6.5 Ammonia Sensor Wiring

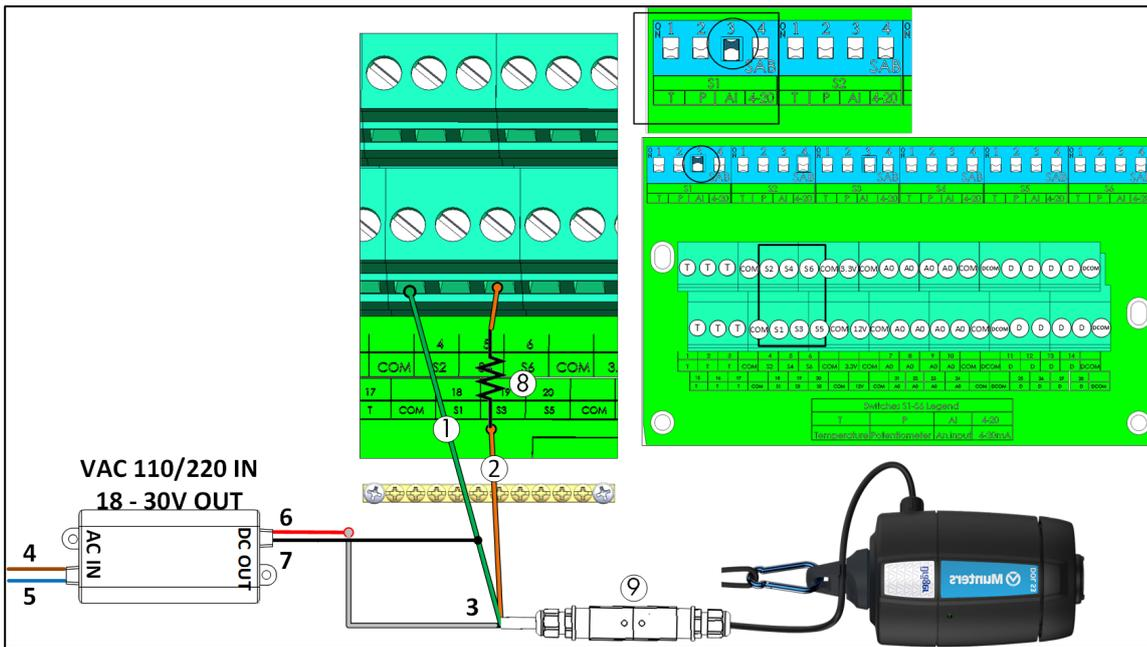

Figure 24: Ammonia Sensor Wiring

| No. | Function |
|-----|--|
| 1 | COM port (Green wire) |
| 2 | S port (Brown wire) |
| 3 | White wire |
| 4 | Phase (Brown wire) |
| 5 | Neutral (Blue wire) |
| 6 | 18-30VDC (Red wire) |
| 7 | COM (Black wire) |
| 8 | 20.3 kohm resistor (Note: The resistor comes supplied with the sensor but must be installed on-site) |
| 9 | Quick connector |

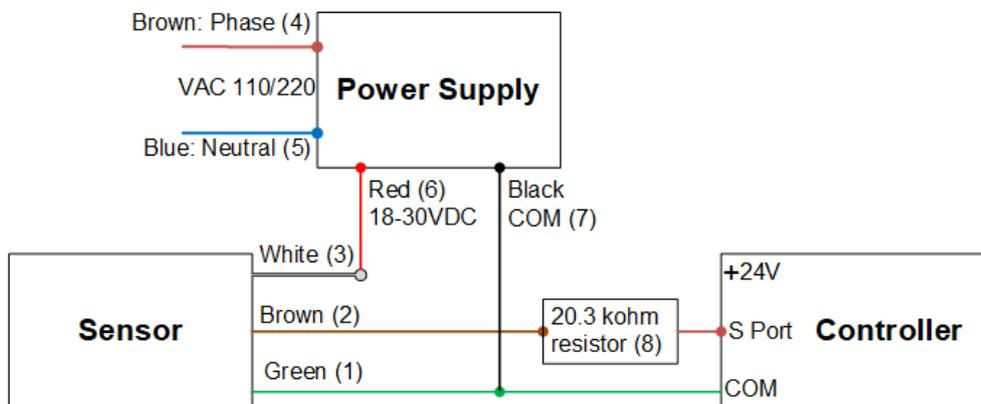

Figure 25: Ammonia Wiring Schematic

- Connect an ammonia sensor to a:
 - S port. In the corresponding dipswitch, raise dipswitch 3 (analog input).

- COM port.

4.4.6.6 Light Sensor Wiring

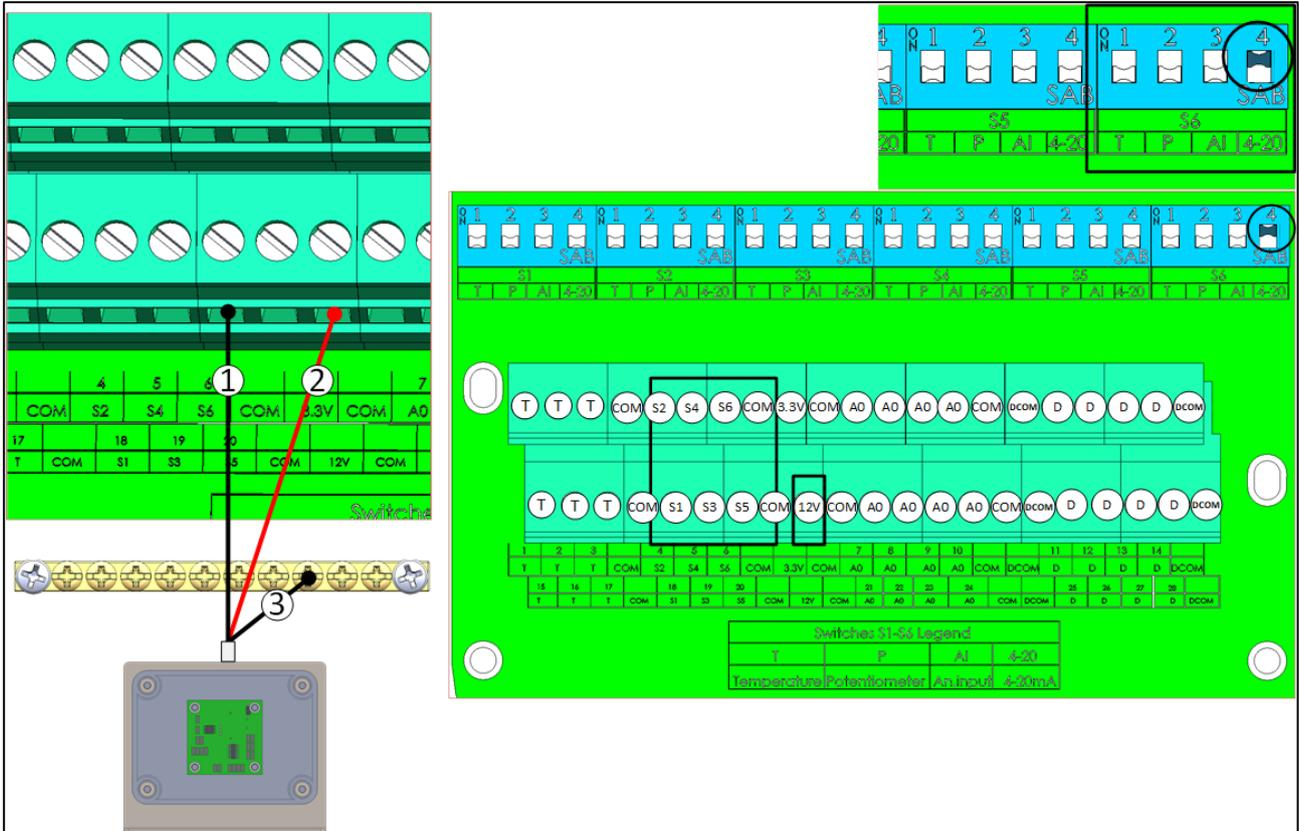
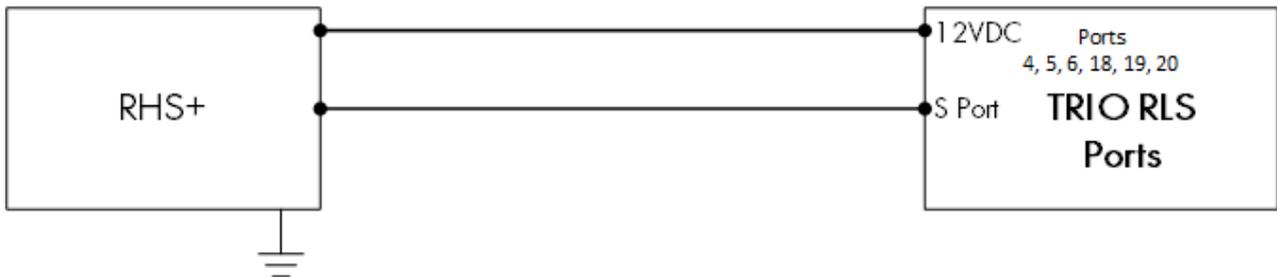

Figure 26: Light Sensor Wiring

| Number | Function |
|--------|---------------------|
| 1 | S port (black wire) |
| 2 | 12V (red wire) |
| 3 | Shield wire |

- Connect each RLS sensor to a:
 - S port. In the corresponding dipswitch, raise dipswitch 4 (4 -20 mA).
 - 12VDC port.
 - Grounding strip!



4.4.7 TRIO RPS

Trio RPS serves as a second static pressure sensor for the Trio Controller. The following section details the installation.

Trio supports up to two static pressure sensors, one built in and one external. Install the RPS in the second room.

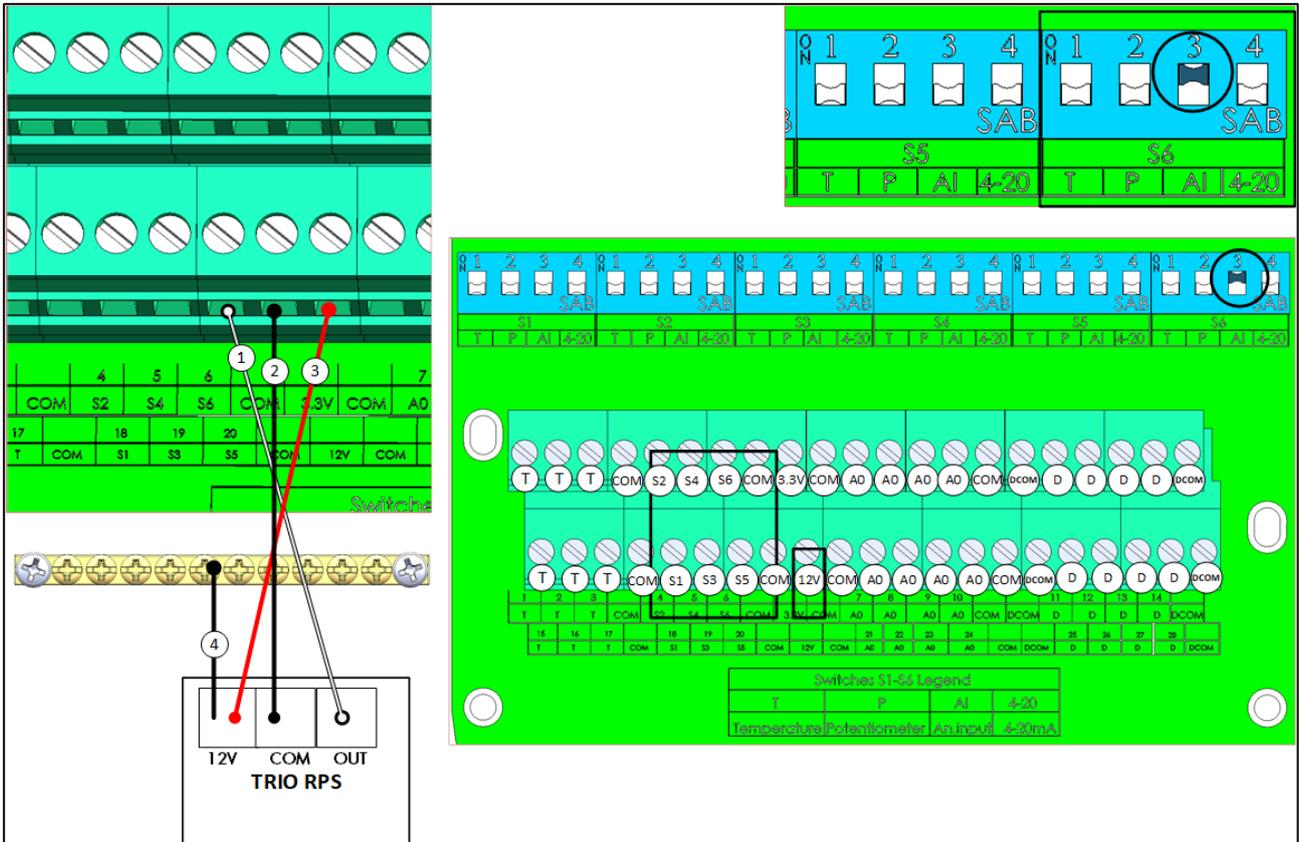

Figure 27: RPS Wiring

| Number | Function |
|--------|---|
| 1 | S port. Raise the corresponding S3 dipswitch. |
| 2 | COM port |
| 3 | 12V |
| 4 | Shield wire |

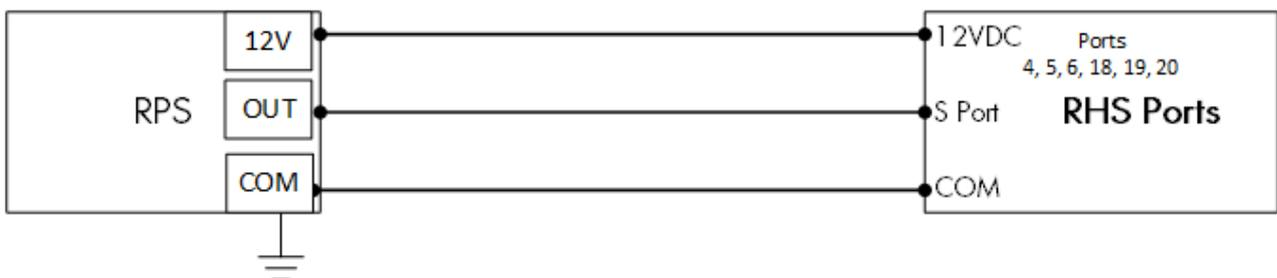

Figure 28: RPS Wiring Schematic

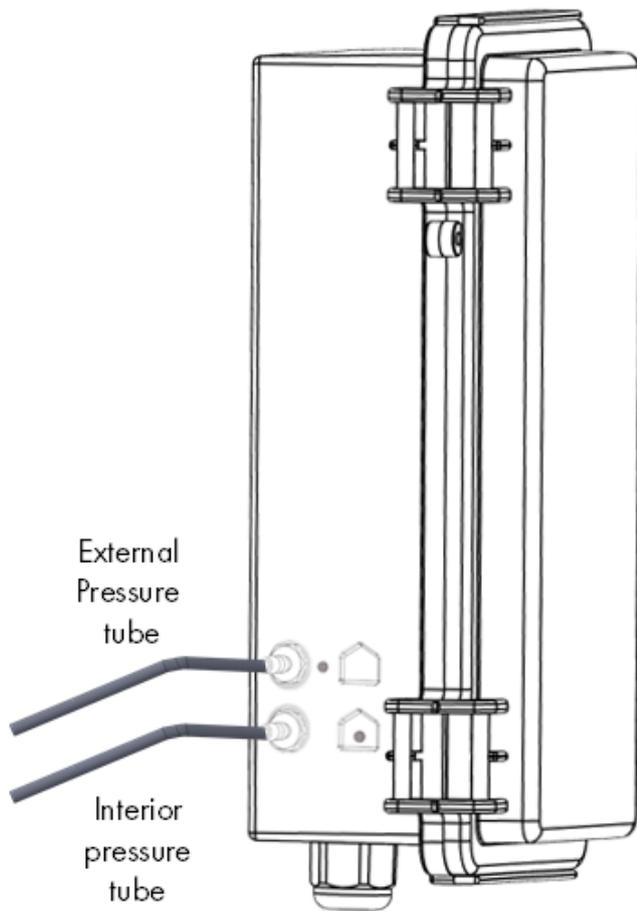

Figure 29: Static pressure tubes

NOTE After installing the RPS, no Cold Start is required.

4.4.8 BIRD SCALE CARD

If you install a scale card, perform a cold start. Refer to the User Manual.

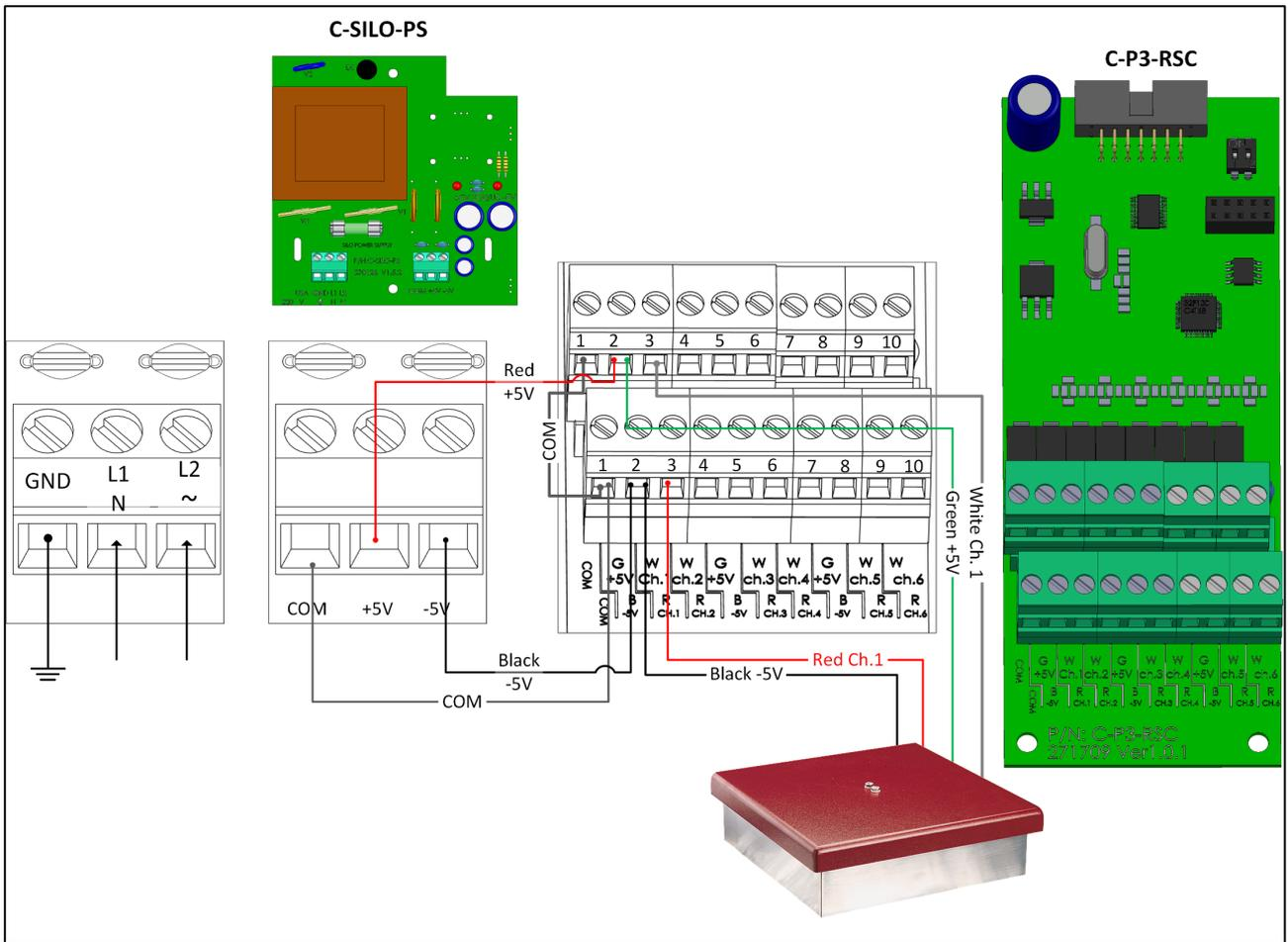

Figure 30: Scale Card wiring to Power Supply and Bird Scale

4.4.9 SILO WIRING

Wire the Trio to an RJB Junction Box and power supply. For details on how to wire the Junction Box to the load cells, refer to the RJB manual.

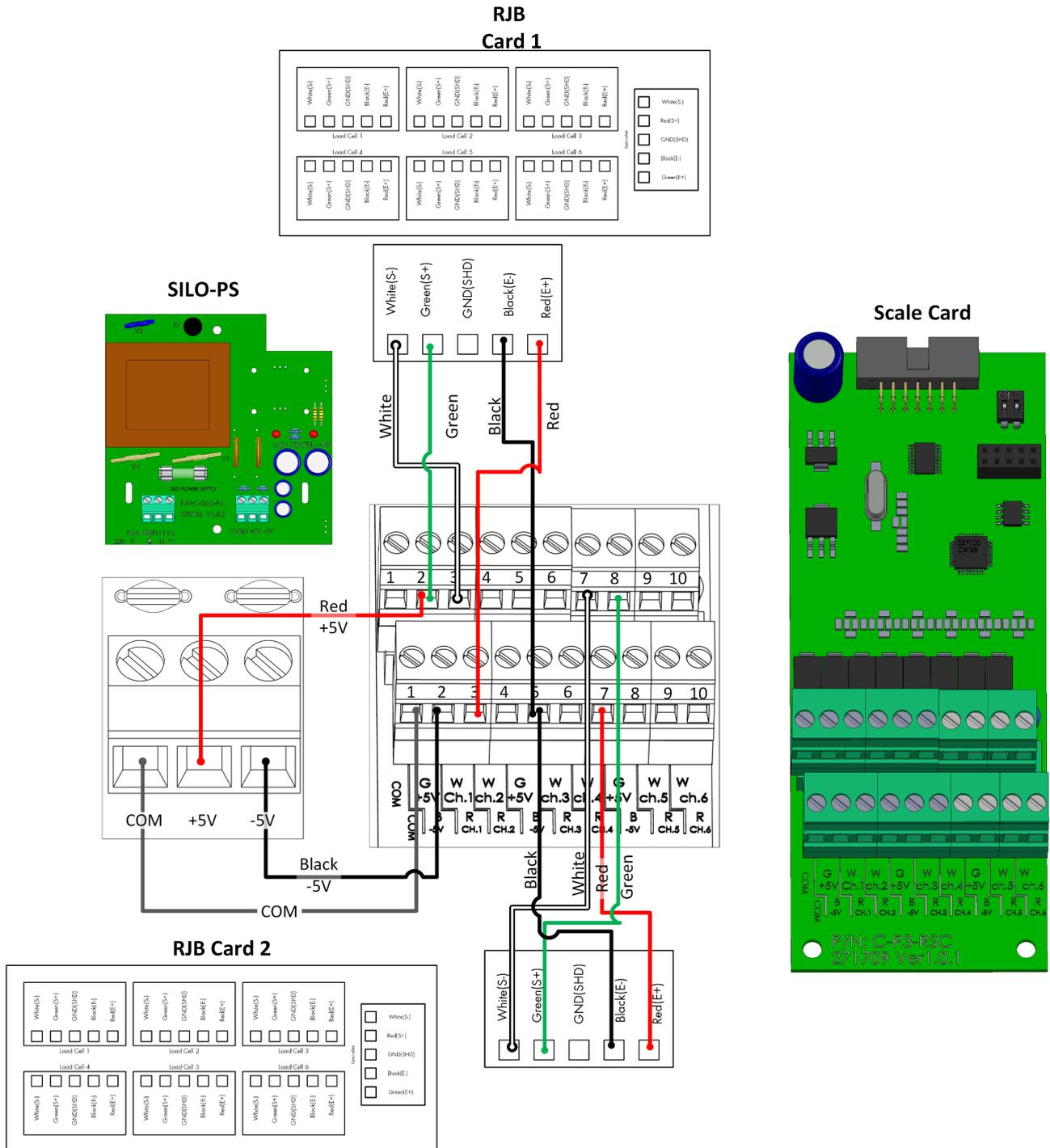

Figure 31: Scale Card wiring to Trio

| RJB Wire | RSC Ports | |
|----------|---------------------------|--|
| Green | 2, 5, 8 (Upper) | |
| Black | 2, 5, 8 (Lower) | |
| White | 3, 4, 6, 7, 9, 10 (Upper) | Note: Connect each RJB white and red wire to matching ports. For example White Ch.1 and Red Ch.1 |
| Red | 3, 4, 6, 7, 9, 10 (Lower) | |

4.4.10 RSU WIRING

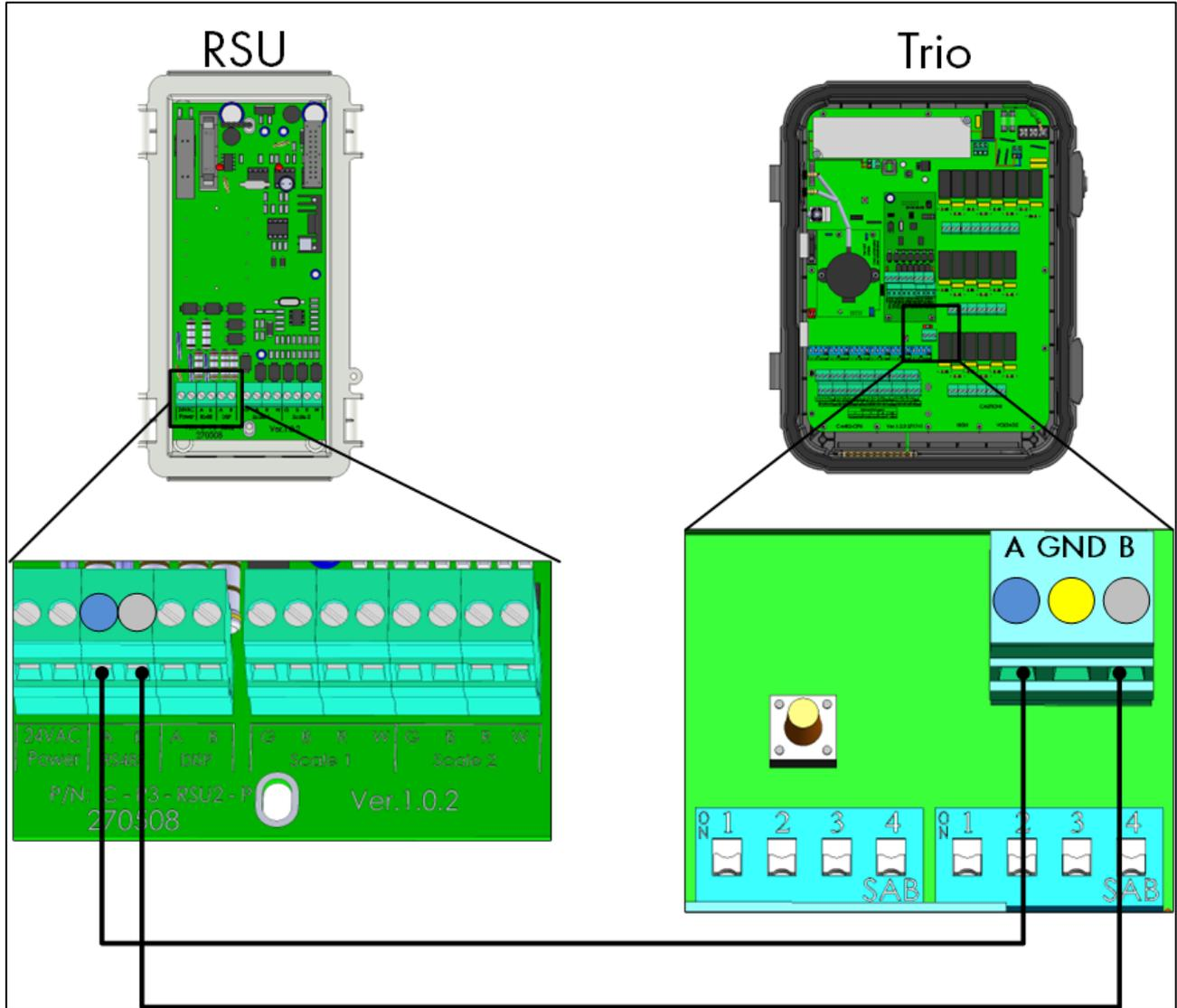

Figure 32: Trio – RSU Wiring

4.5 Pressure Sensor Hoses

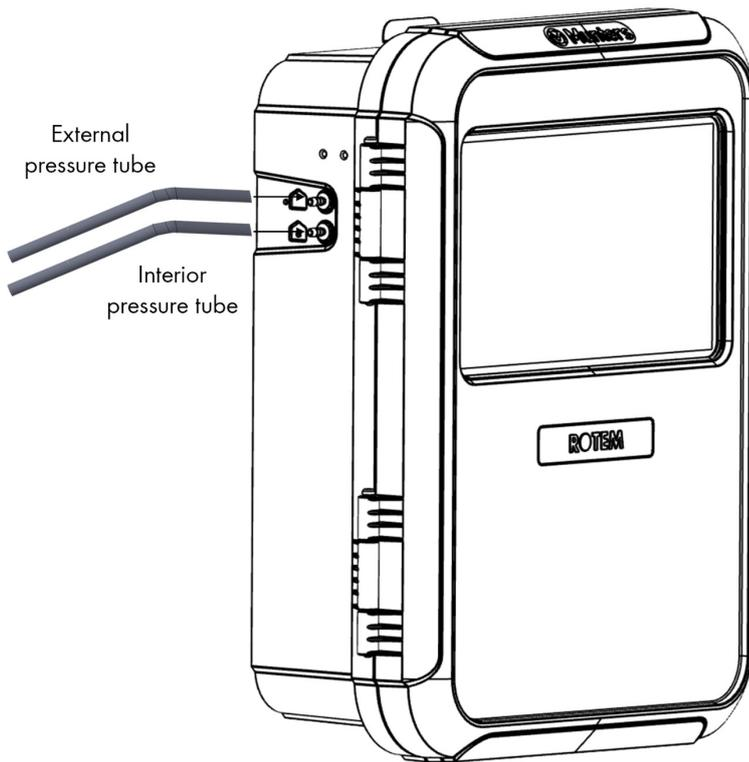

Figure 33: Static pressure hoses

4.6 Key

Ensure that the unit remains locked to prevent unauthorized access to internal components.

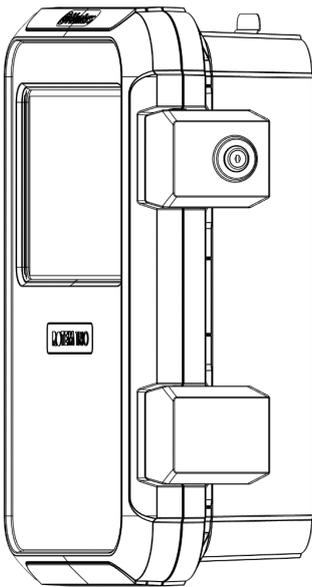

Figure 34: Trio Lock

4.7 Product Symbols

The following labels appear on your controller:



: Caution! Hazardous voltage



: Caution: Refer to the manual



: Main Protective Earthing Terminal

CAUTION IF THE UNIT IS USED IN A MANNER NOT SPECIFIED BY THE MANUFACTURER, THE PROTECTION PROVIDED BY THE EQUIPMENT MAY BE IMPAIRED.

5 TrioAir

Refer to the TrioAir manual for further information.

5.1 Trio Air Accounts

To manage and control your farm, including all Trio units in these farms, set up an account on the trioair.net website. Once an account is setup, you can manage the farms and users from this site or from the TrioAir app. The process is similar to any standard account opening.

1. Go to www.trioair.net or open the app.

NOTE Munters strongly recommends using Google Chrome when using the www.trio.net page.

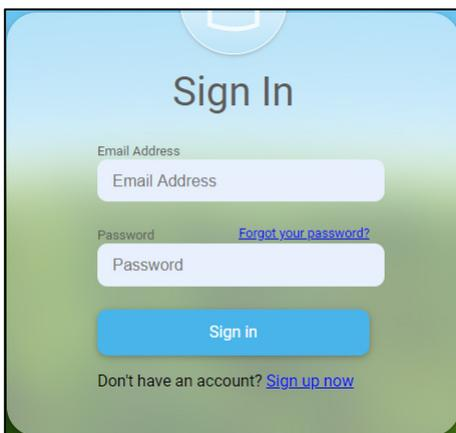

The screenshot shows a mobile application interface for signing in. At the top, there is a white smiley face icon. Below it, the text "Sign In" is displayed in a large, bold font. There are two input fields: "Email Address" and "Password". The "Email Address" field has a light blue border and contains the text "Email Address". The "Password" field also has a light blue border and contains the text "Password". To the right of the "Password" field, there is a blue link that says "Forgot your password?". Below the input fields is a blue button with the text "Sign in". At the bottom of the screen, there is a link that says "Don't have an account? Sign up now".

2. Click Sign Up Now.

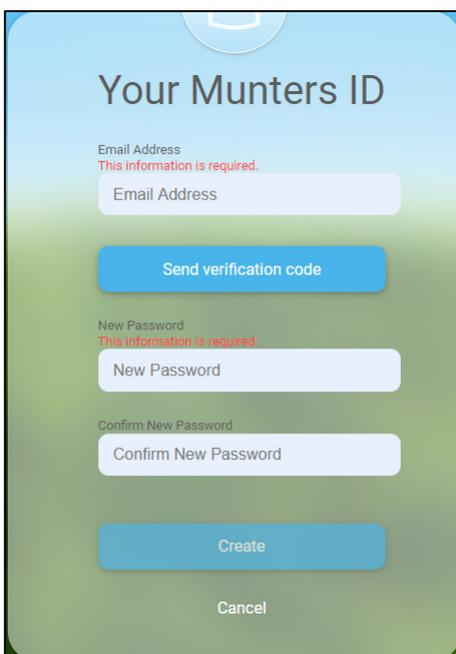

The screenshot shows a mobile application interface for creating a new account. At the top, there is a white smiley face icon. Below it, the text "Your Munters ID" is displayed in a large, bold font. There are three input fields: "Email Address", "New Password", and "Confirm New Password". The "Email Address" field has a light blue border and contains the text "Email Address". Above the "Email Address" field, there is a red error message that says "This information is required.". Below the "Email Address" field is a blue button with the text "Send verification code". The "New Password" field has a light blue border and contains the text "New Password". Above the "New Password" field, there is a red error message that says "This information is required.". Below the "New Password" field is another "New Password" field with a light blue border and the text "Confirm New Password". Below the "Confirm New Password" field is a blue button with the text "Create". At the bottom of the screen, there is a link that says "Cancel".

3. Type in your email address and click **Send verification code**. A code is sent to the email address.
4. Type in the verification code and click **Confirm**.
5. Type in and confirm your password.
6. Click **Create**.

An account is created.

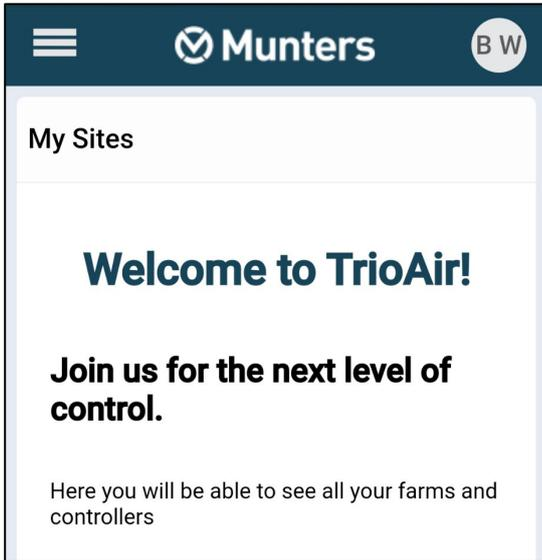

5.2 Pairing a Trio

Pairing a Trio unit to an account enables connecting to the unit via the web/app and managing it remotely. Each Trio unit has a unique ID code (a QR code). This code is used to register the device and pair it to an account. This procedure explains how to pair the device to an account.

NOTE Before attempting to register a Trio, verify that the time and date are correctly set (refer to General Settings > User). In the event that the time and date are incorrect, registration is disabled and an error message appears if attempted.

1. Go to System > General Settings > Network



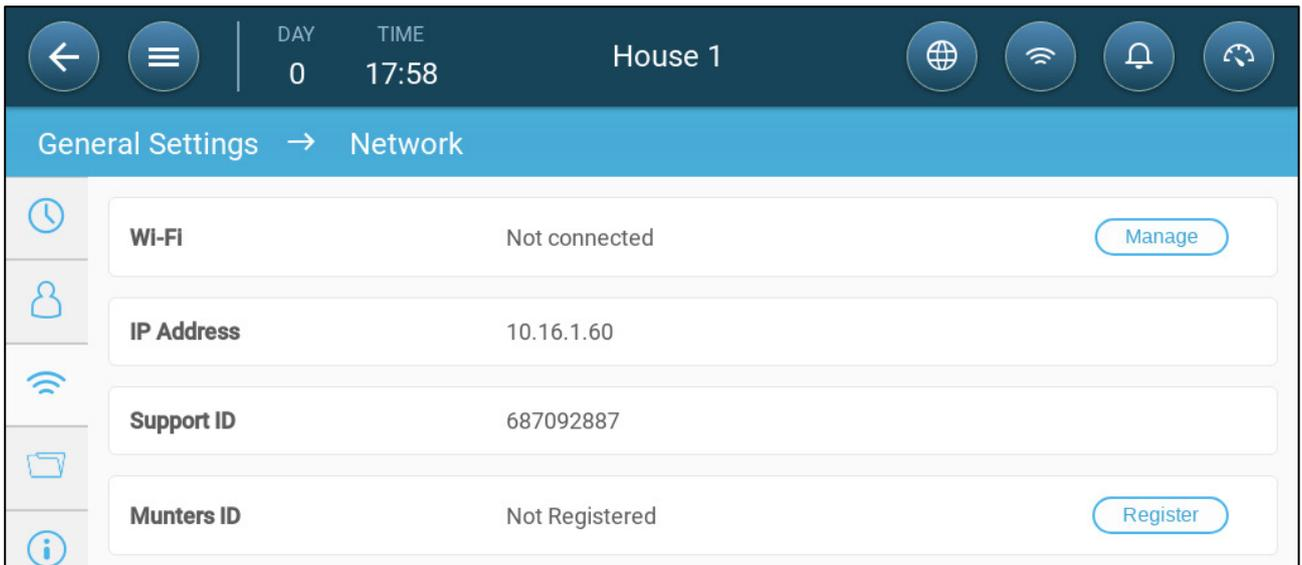

2. Click Register.

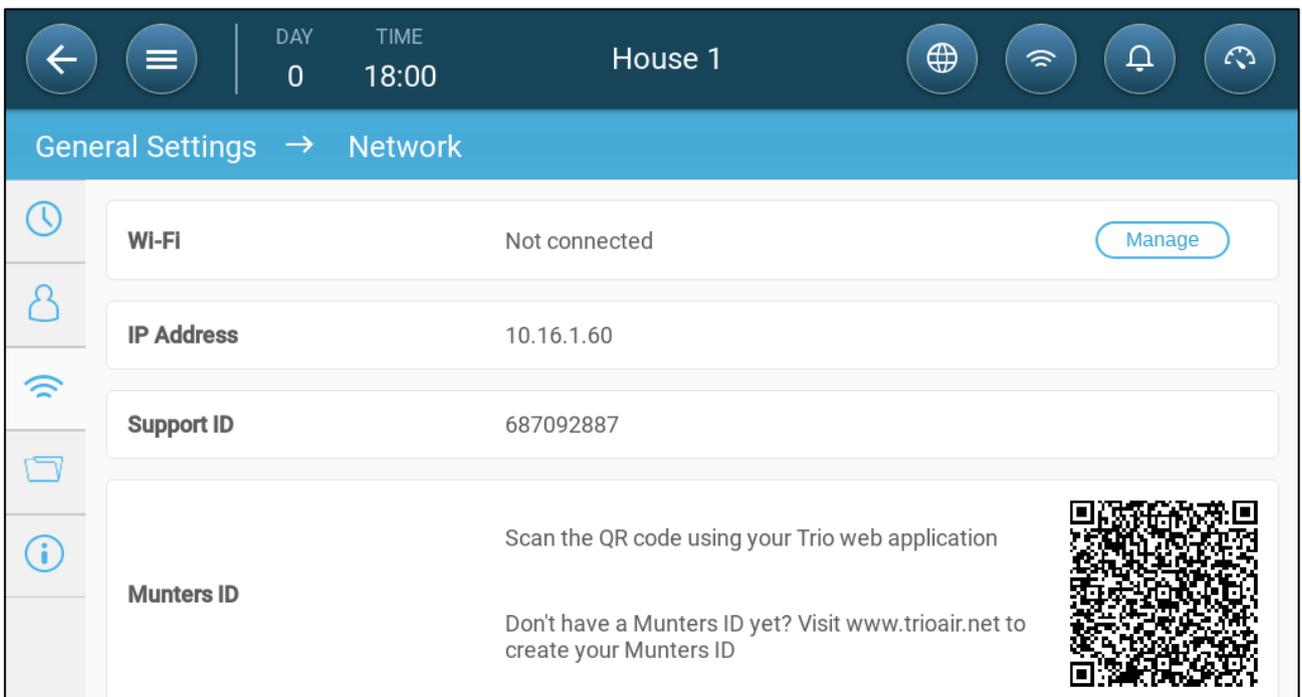

3. Using the TrioAir App (Scan New Device) or a QR reader, scan the QR code. The Trio AIR sign in page appears.

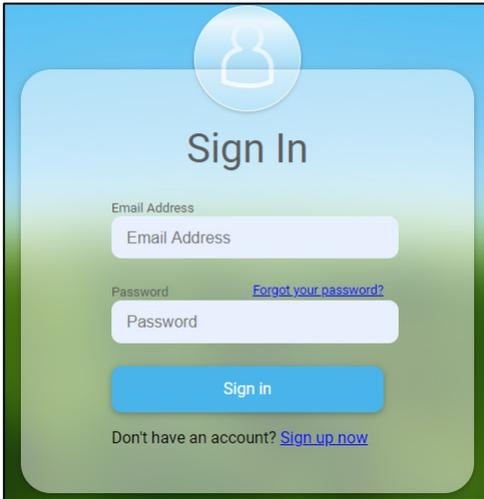

4. Following the online instructions, sign in or create a new account. After signing in, the Trio Air app or web site opens.

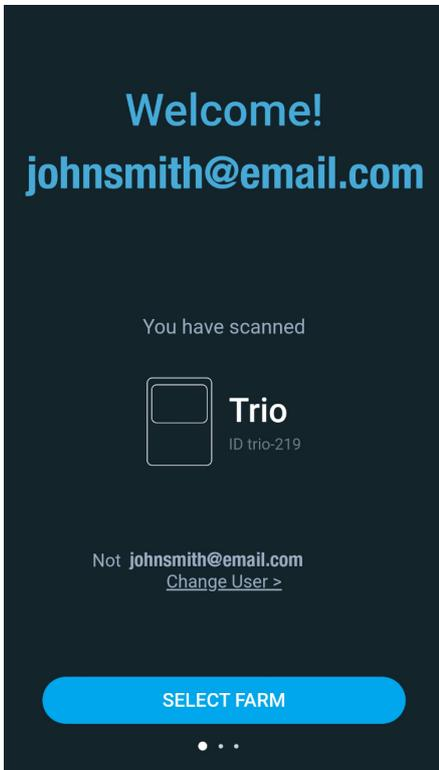

5. Click Select Farm.

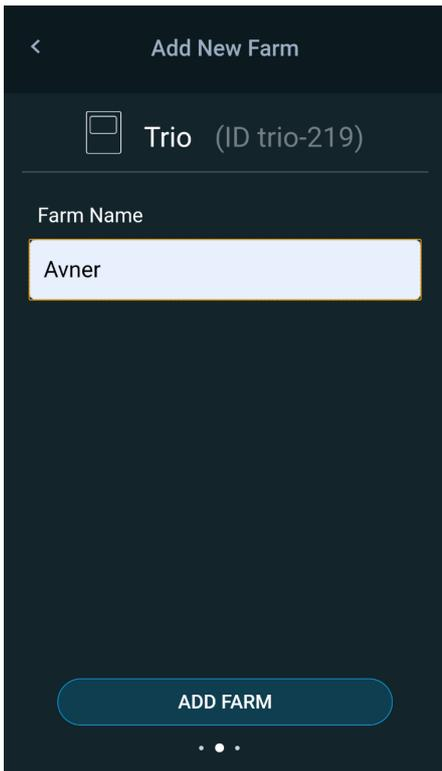

6. Click on an existing account (if there are) or click Add New Farm (follow the online instructions for creating a new farm).

NOTE The person who creates a new farm is automatically defined as the owner. Munters recommends that the person responsible for the farm create the account, and then invite and assign roles to other people.

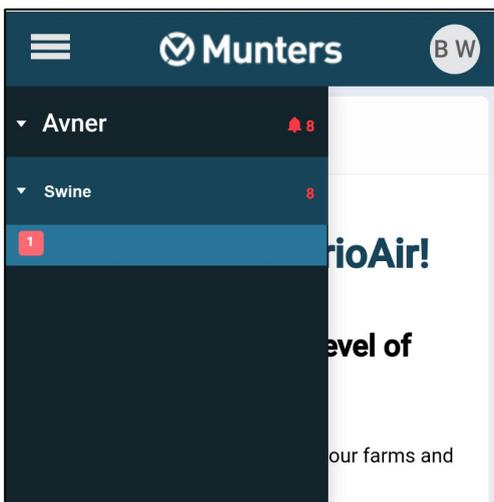

7. Click Register. The Trio unit is now paired with an account.

Controller Registration



Munters ID S M has assigned this device to its account

OK

6 Specifications

| Description | Specification |
|---|--|
| Input Power Voltage | <ul style="list-style-type: none"> • 100 – 240 VAC • 50/60 Hz |
| Input AC Power | 0.75A (at full load (meaning Wi-Fi, internet, cell phone and 20 relays ON)) |
| Relays | 1 Amp. Up to 60% of the relays can operate at any given time. |
| <i>Note: Running relays at the above current levels provides between 50,000 – 100,000 switching operations.</i> | |
| Analog Inputs | 0 – 3.3 Volts |
| Analog Output | 0 – 10 Volts; maximum load: 20 mA |
| Digital Inputs | 3.3 Volts, 1.5 mA, dry contact |
| Communication | <ul style="list-style-type: none"> • LAN – Standard 10/100 BaseT • Expansion – RS-485: 115 Kbps, 8 bit, even parity |
| Operating and Storage Temperature Range | -10° to +50° C (+14° to +125° F) |
| Environmental Specifications | <ul style="list-style-type: none"> • Altitude: -400 m to 2000 m • Relative Humidity: 20% - 70% • Main supply voltage fluctuation up to 5% • Overvoltage category II |
| Enclosure | <ul style="list-style-type: none"> • Water and dust tight • Indoor use only |
| Dimensions (H/W/D) | 403 x 324 x 141 mm/16 x 13 x 5.6 inches |
| Fuses | Fuse F2 on PS card: 3.15A, 250V |
| Certification |     |

- **Disconnection device/overcurrent protection:** In the building installation, use a certified 2-pole circuit breaker rated 10A, certified in accordance with the IEC standard 60947-2 (in the US and Canada use a Listed Branch Circuit protective circuit breaker). This step is required to provide overcurrent protection and mains disconnection. The circuit breaker must be easily accessible and marked as the controller disconnect device.
- **Main Supply Voltage:** Permanently connect the controller to the mains in accordance with the relevant national code. Provide fixed wiring inside a flexible conduit. Relays must be suitably protected against overcurrent, using a circuit breaker rated at 10A.

7 Using the Trio Touch Screen

|  | |
|---|---|
|  | Go back to the previous screen |
|  | View the Main menus |
|  | Choose language |
|  | Network settings |
|  | View alarms |
|  | Go back to the main screen |
|  | Settings icon |
|  | Edit parameters |
|  | Replace the dashboard battery with a standard 3V battery. |
| Phone App | |
|  | Click the circle containing the user name to edit personal preferences such as the language, units, name, and more. |

 Send To All

When a Trio controls two or more rooms or there are two or more houses on a farm, Send to All enables editing certain select functions in more than one room or house. Edit the setting, click Send to All, and select the required Trios. The select rooms' or houses' settings are updated. Note: Send to All does not appear on every screen.

8 Mapping and Defining the Input Output Devices

NOTE Munters recommends that a trained technician perform the following operations.

- Mapping Devices
- Temperature Sensors
- Ventilation Devices
- Sensors
- Heating Devices
- Defining the Cooling Devices
- Inlets, Tunnel Doors, Outlets
- Defining the Same As Relays
- Defining the Same As Analog Ports
- Defining the Timer
- Defining the Auxiliary Input
- Lighting Devices
- Feeding Devices
- Defining the Silos
- Defining the Bird Scales
- Defining the RSU
- Defining the Trio RPS

8.1 Mapping Devices

After wiring devices to the Trio, each device must be mapped and then defined. Mapping and defining devices enable the system software to control each device's functionality.

CAUTION *Mapping MUST match the physical wiring! An error message appears if the physical device is not wired to the relay or port as defined on the mapping screen..*

To map the devices:

1. Go to System > Device and Sensors.

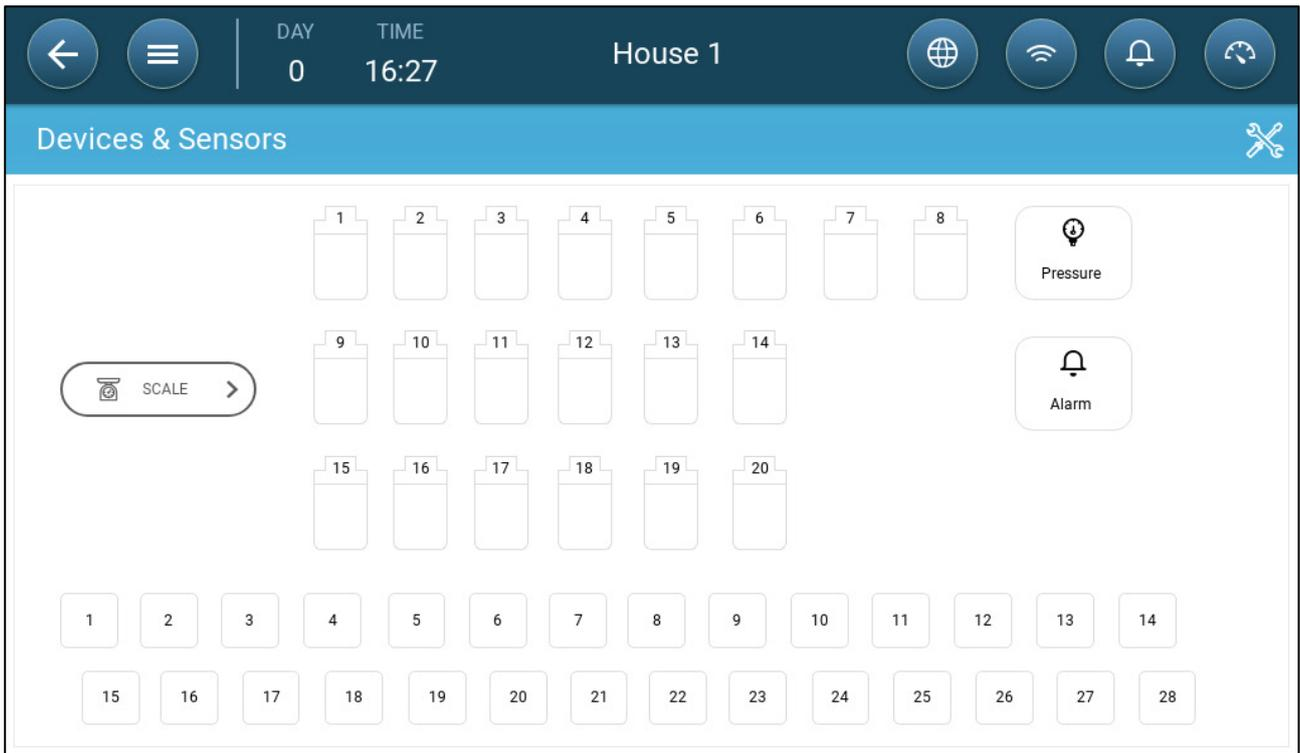

This screen displays the relays and analog/digital ports. At this point, all icons are undefined.

2. Click .

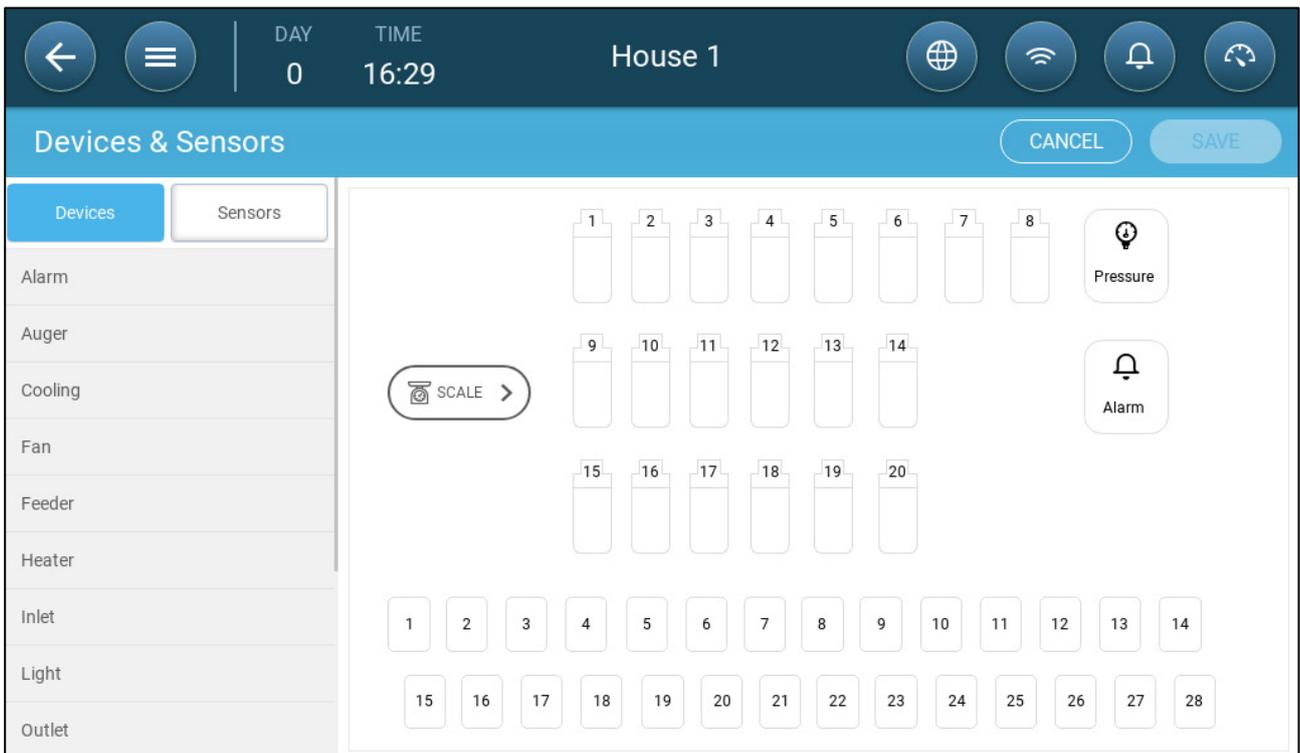

- Click **Devices** to map cooling devices, heaters, inlets, fans, stir fans, timers, tunnel doors, outlets, or the alarm relay.
 - Click **Sensors** to map auxiliary inputs, sensors (humidity, pressure, temperature, CO2, ammonia), water meter, and potentiometers.
3. Under Devices or Sensors, click the type of device that you want to map. In the following example, Heater is selected. The screen displays the relays and ports that can be defined as heaters.

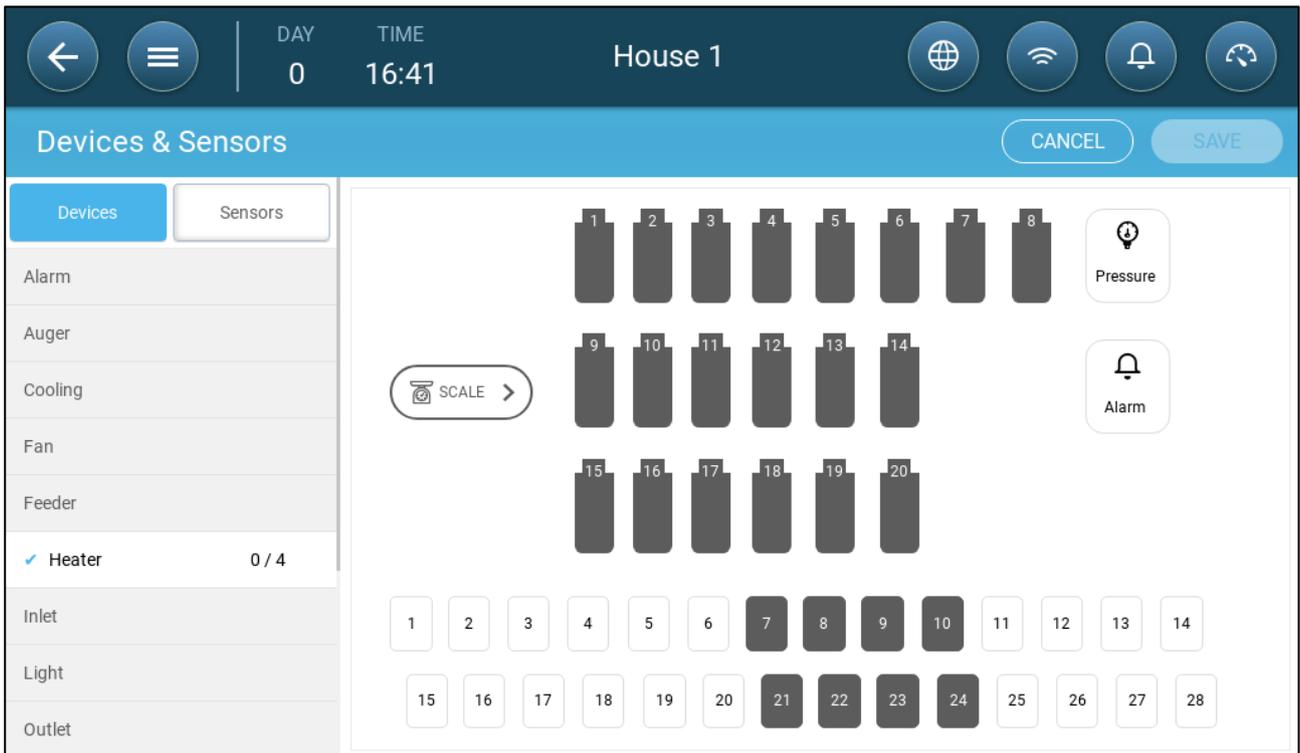

4. Click on the relays and/or ports that you wired to heaters.
- Trio automatically numbers the devices.
 - Trio enables selecting up to the maximum number of each device.
 - Devices having opening and closing relays require mapping both relays.
5. Repeat steps 3 and 4 for all the connected devices.

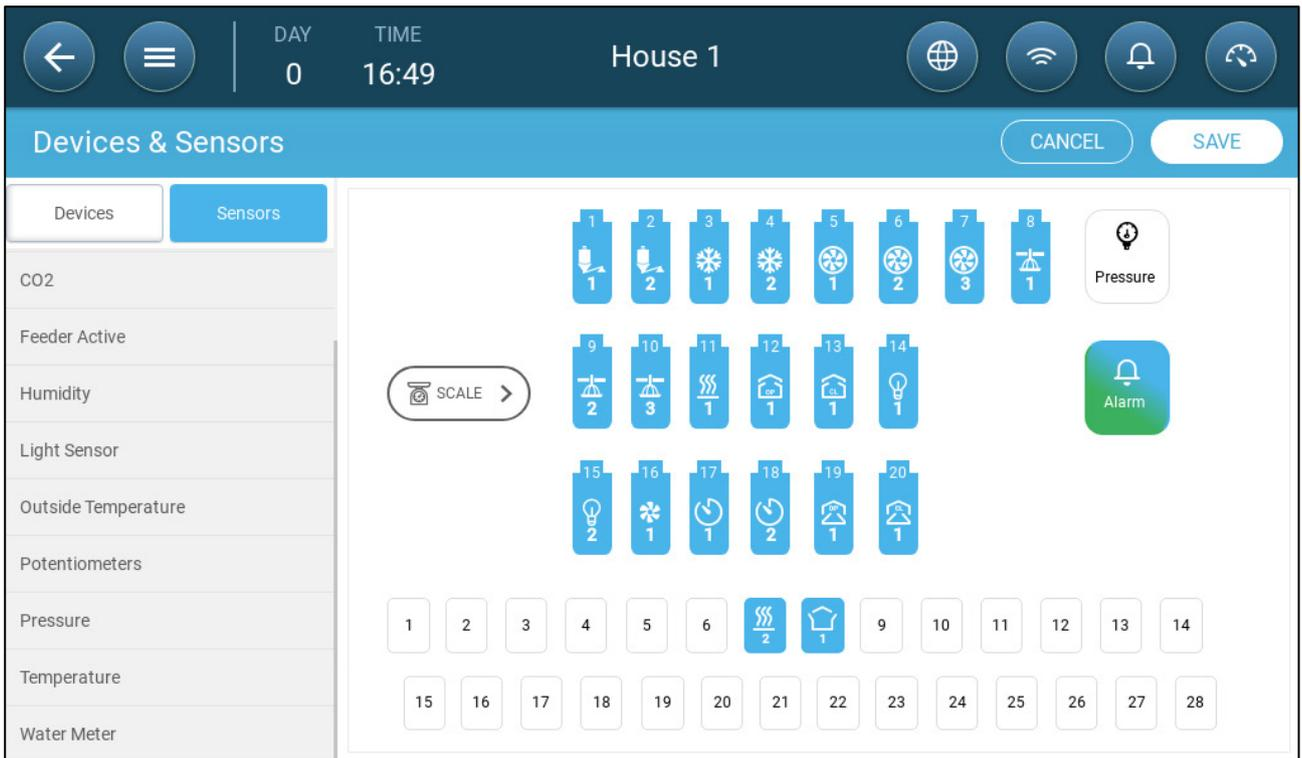

6. After mapping all installed devices, click **SAVE**.

NOTE To un-map a device, click on the required device and hold the icon down.

NOTE If you map a sensor that is not physically connected to the Trio, an error symbol appears on the designated analog port.

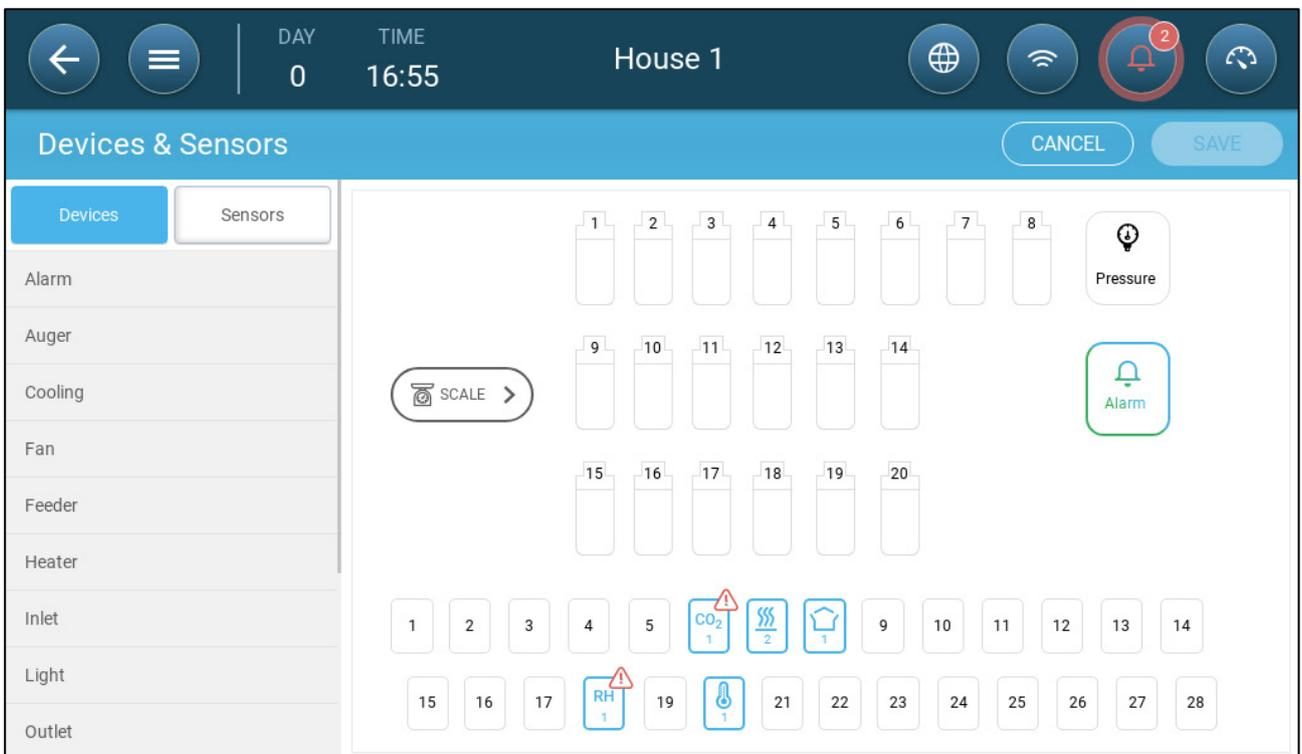

8.2 Temperature Sensors

- Defining the Temperature Sensors
- Mapping the Temperature Sensors
- Enabling a Weather Station

8.2.1 DEFINING THE TEMPERATURE SENSORS

- Define up to 12 analog input ports as temperature sensors (and one port as an outside temperature sensor) (refer to Mapping Devices).

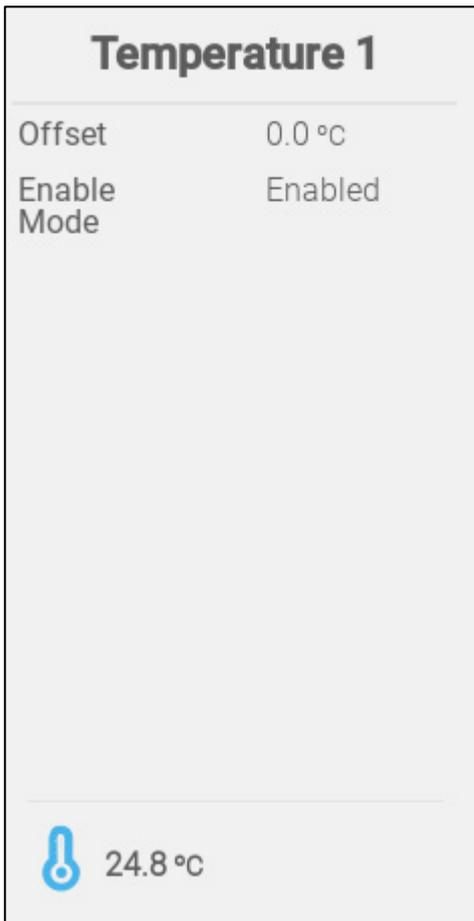

- Define:
 - Offset: This is an optional correction for the temperature sensor. Range: -10° C to +10° C
 - Enabled: enable/disable the sensor.
- The temperature reading shows the measured temperature, including the offset.

8.2.2 MAPPING THE TEMPERATURE SENSORS

Calculating the temperature data, Trio takes the following into consideration:

- Tunnel temperature: Select a sensor or a group of sensors to determine the tunnel temperature readings or select if the tunnel runs according to the average temperature reading.
- Average temperature: Data from multiple sensors can be averaged. If a sensor fails, the sensor's data is removed from any calculations.

- Device temperature: A sensor (or sensors) can be mapped to a specific device.
- Outside temperature: The temperature sensor defined as an outside temperature is not included in any average calculation.

Map specific temperature sensors to specific devices.

- Go to System > Temperature Definition.

| Device | Avg. | Temperature Sensors | Outside |
|------------|------|---------------------|---------|
| Full House | | 1 3 | |
| Cooling 1 | ✓ | | |
| Timer 1 | | 1 | |
| Timer 2 | | | ✓ |
| Timer 3 | | 2 | |

- Map the sensors to devices.
 - Define which sensors are used to calculate the average temperature.
 - If an outside temperature sensor is enabled, map timers to it (if required).

NOTE Uninstalling a device in the Relay Layout, Analog Output or TRIAC tables removes the device from this screen.

8.2.3 ENABLING A WEATHER STATION

To save costs on temperature sensors, one outdoor temperature sensor can provide data to the entire Trio network.

NOTE Install and map one outdoor sensor only.

1. In System > Device and Sensors, define one sensor as Outside Temperature.

2. Go to System > Control Strategy > Weather Station .

| Control Strategy | Weather Station |
|---------------------------------|-----------------|
| Receive Outside Temp. Broadcast | Enabled |

3. Enable Receive Outside Temp. Broadcast.

8.3 Ventilation Devices

- Defining the Fans
- Defining the Stir Fan

8.3.1 DEFINING THE FANS

The following sections detail how to configure fans.

NOTE These settings should be configured by a technician familiar with the fan and inlet/curtain specifications.

Fan air capacity defines how much air is provided when the fans run at full speed. These numbers are used to calculate minimum air requirements.

- In General Settings > User define the measurement unit.
- Define up to 20 relays or analog output ports as On/Off or 0 – 10 V fans, respectively (refer to Mapping Devices, page 48).
 - On-Off Fans
 - 0 – 10 Volt Fans

8.3.1.1 On-Off Fans

1. On the Device and Sensors screen, click a fan relay.



2. Click .

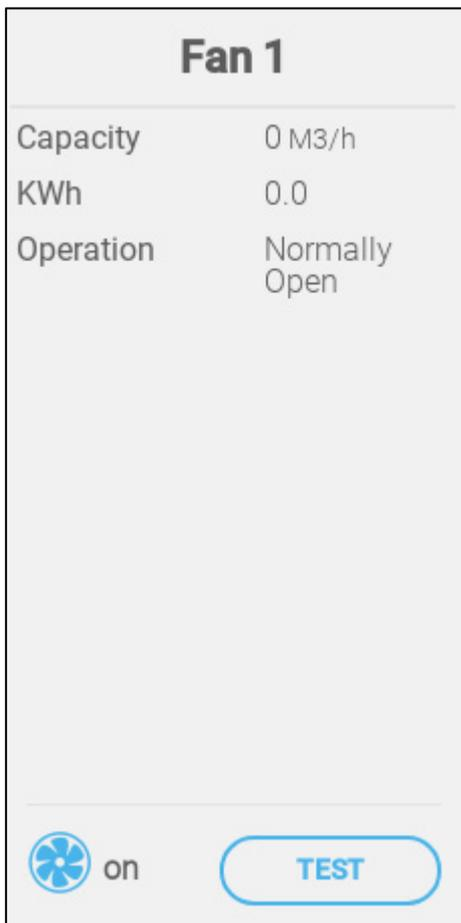

3. Edit the parameters.
 - Capacity: Enter the fan capacity.
 - KWh: This field displays the amount of kilowatts used. Read-only.
 - Operation: Select if the relay is normally open or normally close.
4. Click Save.

8.3.1.2 0 – 10 Volt Fans

1. On the Device and Sensors screen, click a fan analog output port.



2. Click

Fan 1

| | |
|-------------------|--------|
| Min. Voltage (V) | 0.0 |
| Max. Voltage (V) | 10.0 |
| Capacity | 0 M3/h |
| KWh | 0.0 |
| Boost Time (sec.) | 5 |

0.0

TEST

3. Edit the parameters.
 - Minimum/Maximum Voltage: Enter the minimal and maximal voltage used to calibrate the fan speed. For example, if the minimum voltage is set to 2V and the maximum to 8V the controller applies the calculated 0-100% output over a 2V-8V signal.
 - Capacity: Enter the fan capacity.
 - KWh: This field displays the amount of kilowatts used. Read-only.
 - Boost Time: During this amount of time, the controller applies full power to the fan motor (100%).
4. Click Save.
5. To test in the minimal and maximum voltages, click Test.

8.3.2 DEFINING THE STIR FAN

- Define one relay or port as a stir fan (refer to Mapping Devices, page 48).
 - On Off Stir Fan
 - 0 – 10 Volt Stir Fan

8.3.2.1 On Off Stir Fan

Stir Fan 1

| | |
|-----------|------------------|
| KWh | 0.0 |
| Operation | Normally Open |

 off TEST

- Define:
 - KWh: This field displays the amount of kilowatts used. Read-only.
 - Operation: Define the relay mode.
- The status shows if the stir fan is currently operating.

8.3.2.20 – 10 Volt Stir Fan

| Stir Fan 1 | |
|--------------|------|
| Min. Voltage | 0.0 |
| Max. Voltage | 10.0 |
| KWh | 0.0 |

 0.0 TEST

- Minimum/Maximum Voltage: Enter the minimal and maximal voltage used to calibrate the fan speed.
- KWh: This field displays the amount of kilowatts used. Read-only.

8.4 Sensors

- Defining the Ammonia Sensor
- Defining the CO2 Sensor
- Defining the Humidity Sensor
- Defining the Water Meter Sensor
- Defining the Gas Meter Sensors

8.4.1 DEFINING THE AMMONIA SENSOR

- Define one analog input port as an ammonia sensor (refer to Mapping Devices, page 48).

| Ammonia 1 | |
|-------------|---------|
| Offset | 0 |
| Enable Mode | Enabled |

NH₃ 20

- Define:
 - Offset: This is an optional correction for the ammonia sensor. Range: -10 to +10 ppm
 - Enable Mode: Enable/disable the sensor.
- The ammonia reading shows the measured amount, including the offset.

8.4.2 DEFINING THE CO2 SENSOR

- Define one analog input port as a CO2 port (refer to Mapping Devices, page 48).

| CO2 1 | |
|--------------------------|---------|
| Offset | 0 |
| Enable Mode | Enabled |
| <hr/> | |
| CO ₂ 1,8740.0 | |

- Define:
 - Offset: This is an optional correction for the CO2 sensor. Range: -500 to +500 ppm
 - Enable Mode: Enables/disables the sensor.
- The CO2 reading shows the measured amount, including the offset.

8.4.3 DEFINING THE HUMIDITY SENSORS

➤ Define (refer to Mapping Devices, page 48):

- One or two analog input ports as a humidity sensor
- One analog input port as an outside humidity sensor

| Humidity 1 | |
|-------------|---------|
| Offset | 0 |
| Enable Mode | Enabled |
| <hr/> | |
| RH 53.0 | |

| Outside Humidity 1 | |
|--------------------|-------------------------------------|
| Offset | 0 |
| Enable Mode | <input checked="" type="checkbox"/> |
| <hr/> | |
| RH N/A | |

- Define:
 - Offset: This is an optional correction for the humidity sensor. Range: -10 to +10%
 - Enable Mode: Enables/disables the sensor.
- The humidity reading shows the measured level, including the offset.

8.4.4 DEFINING THE WATER METER SENSORS

- Define up to four (4) digital input ports as a water meter (refer to Mapping Devices, page 48).

| Water Meter 1 | |
|---------------|----------------|
| Quan./Pulse | 1.0 |
| Meter Input | Drinking Water |
| Enable Mode | Enabled |

 off

- Define:
 - Quan/Pulse: Set the water meter's water flow per pulse. Range: 0.0 to 99.9 (unit depends on the General Settings > User.)
 - Meter input: Chose drinking water or cooling.
 - Enable Mode: Enable/disable the sensor.

8.4.5 DEFINING THE GAS METER SENSORS

- Define up to three digital input ports as a gas meter (refer to Mapping Devices, page 48).

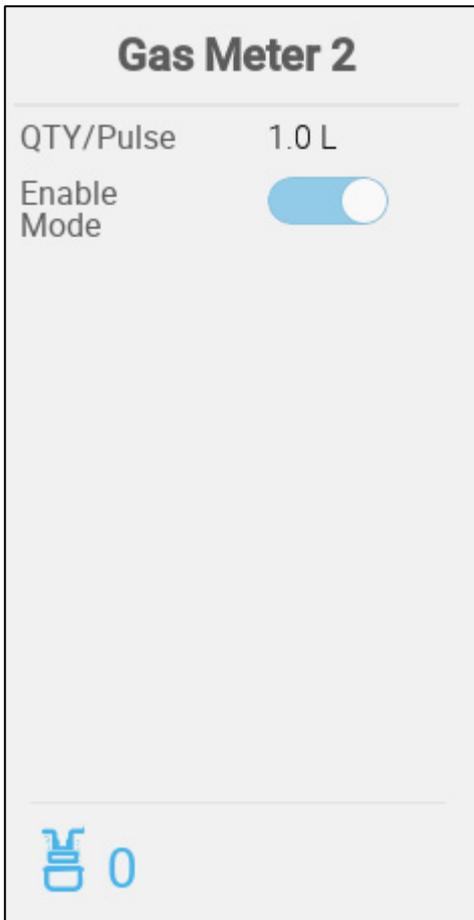

Gas Meter 2

QTY/Pulse 1.0 L

Enable Mode

 0

- **Quan/Pulse:** Set the gas meter's flow per pulse. Range: 0.0 to 999 (unit depends on the General Settings > User.)
- **Enable Mode:** Enable/disable the sensor.

8.5 Heating Devices

➤ Define up to six relays and/or analogue output ports as heaters (refer to Mapping Devices, page 48).

- Defining the On/Off Heaters
- Defining the Variable Heaters

8.5.1 DEFINING THE ON/OFF HEATERS

The screenshot shows the configuration page for 'Heater 1'. It features a title 'Heater 1' at the top. Below the title, there are four main configuration sections: 'Zone Heater' with a toggle switch currently turned off; 'KWh' with a text input field containing '0.0'; 'Operation' with a dropdown menu set to 'Normally Open'; and another 'Operation' dropdown menu set to 'Continues'. The word 'Mode' is listed at the bottom of the configuration area but has no associated controls visible.

- Define:
 - Zone Heater:
 - Disable (default): Central Heaters, the heater output is related to the target temperature, these heaters operate according to the average temperature (no temperature sensors can be assigned to it).
 - Enable: Zone Heater, the heater output has its own target set-point and its own sensors assigned to it. Zone heater will enable the assignment of temperature sensor/s in temperature definition.
 - Operation: Define the relay mode.
 - Operation Modes
 - Continues (default): The heater starts to operate continuously.
 - Cycle: This option enables the operation of heater in cycles.

8.5.2 DEFINING THE VARIABLE HEATERS

Heater 2

Min. Voltage

Max. Voltage

Zone Heater

KWh

- Define:
 - Min./Max Voltage: Define the voltage in the analogue output port that corresponds to the 0% and 100% output, respectively.
 - Zone Heater:
 - Disable (default): Central Heaters, the heater output is related to the target temperature, these heaters operate according to the average temperature (no temperature sensors can be assigned to it).
 - Enable: Zone Heater, the heater output has its own target set-point and its own sensors assigned to it. Zone heater enables the assignment of temperature sensor/s in temperature definition.
 - KWh: This field displays the amount of kilowatts used. Read-only.

8.6 Defining the Cooling Devices

➡ Define up to two relays as cooling devices (refer to Mapping Devices, page 48).

Cooling 1

KWh 0.0

Operation Normally
 Open

❄ off TEST

- Define:
 - KWh: This field displays the amount of kilowatts used. Read-only.
 - Operation: Define the relay mode.
- The status shows if the cooling device is currently operating.

8.7 Inlets, Tunnel Doors, Outlets

- Mapping the Potentiometers
- Defining the Inlets/Tunnel Doors
- Defining the Outlet

8.7.1 MAPPING THE POTENTIOMETERS

➡ Define up to four analogue ports as potentiometers.

As an option, potentiometers enable exact positioning of relay-controlled inlets\tunnel doors when calibrating. If:

- potentiometers are not employed or
- there is a potentiometer failure

opening and closing times are used to calibrate the inlets/tunnel doors.

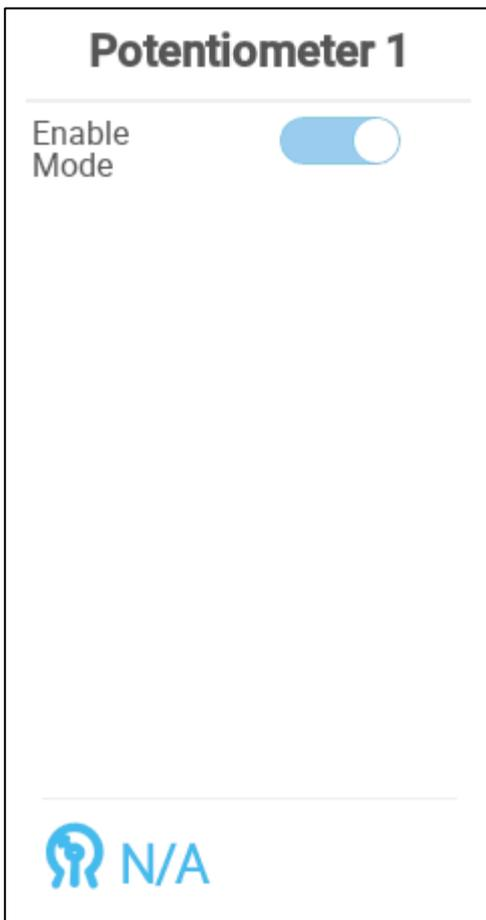

- Enable/disable the potentiometer.

8.7.2 DEFINING THE INLETS/TUNNEL DOORS

- Define up to four relays or analog output ports as inlets or tunnel doors (each device requires two relays or one analogue port) (refer to Mapping Devices, page 48).

| Inlet 2 | | Tunnel Door 1 | |
|--|-------------------------------------|--|-------------------------------------|
| Position | By Time | Position | By Pot. 1 |
| Auto Calib. | <input checked="" type="checkbox"/> | Auto Calib. | <input checked="" type="checkbox"/> |
| Power-up Calib. | <input type="checkbox"/> | Power-up Calib. | <input checked="" type="checkbox"/> |
| Open Time (sec.) | 60 | Open Time (sec.) | 60 |
| Close Time (sec.) | 60 | Close Time (sec.) | 60 |
| Open Relay Normal State | Normally Open | Open Relay Normal State | Normally Open |
| Close Relay Normal State | Normally Open | Close Relay Normal State | Normally Open |
| | | <input type="button" value="CALIBRATE"/> | |
| <input type="button" value="Close"/> <input type="button" value="TEST"/> | | <input type="button" value="Close"/> <input type="button" value="TEST"/> | |

- Define:
 - Normal State
 - Position: Define how the inlet opening is controlled:
 - By time
 - Potentiometer. (relay-controlled inlets or tunnel doors only). Map each inlet/tunnel door to a potentiometer. This option appears only if potentiometers are mapped.
 - Auto Calib.: Enable automatic calibration.
 - Power up calibration: Enable this parameter to calibrate inlets each time that Trio is turned on.
 - Open/Close Time: Enter the amount of time required to fully open or fully close the inlet. These parameters are only enabled when Position/By Time is selected.
 - Calibrate: Manually calibrate inlets/tunnel doors positioned by a potentiometer. Potentiometer-controlled calibration only.

8.7.2.1 Potentiometer Calibration

If used, a potentiometer can control the opening and closing with a high degree of precision. When there is no potentiometer, positioning accuracy tends to degrade after the inlets go through several opening and closing cycles.

In order to calibrate the inlets/vents using a potentiometer:

- Install and map at least one potentiometer.
- Calibrate the potentiometer. Calibration must be successful.

In for any reason potentiometer calibration does not function:

- calibration is by time (auto and/or at power up). Time calibration does not fail.
- A potentiometer alarm is generated (if alarms are enabled) . The alarm must be reset to enable potentiometer calibration to function.

8.7.2.2 Calibrating the Inlets/Tunnel Door

During installation, the user enables auto-calibration or power up calibration in digital output (relay) inlets. Calibration automatically takes place after the number of inlet movements equals the number of movements required to start calibration or at Trio power up.

Only one inlet or tunnel curtain can be calibrated at a time.

- Relay open occurs when the target position is 100%.
- Relay close occurs when the target position is 0%.

1. Go to System > Control Strategy > Ventilation .

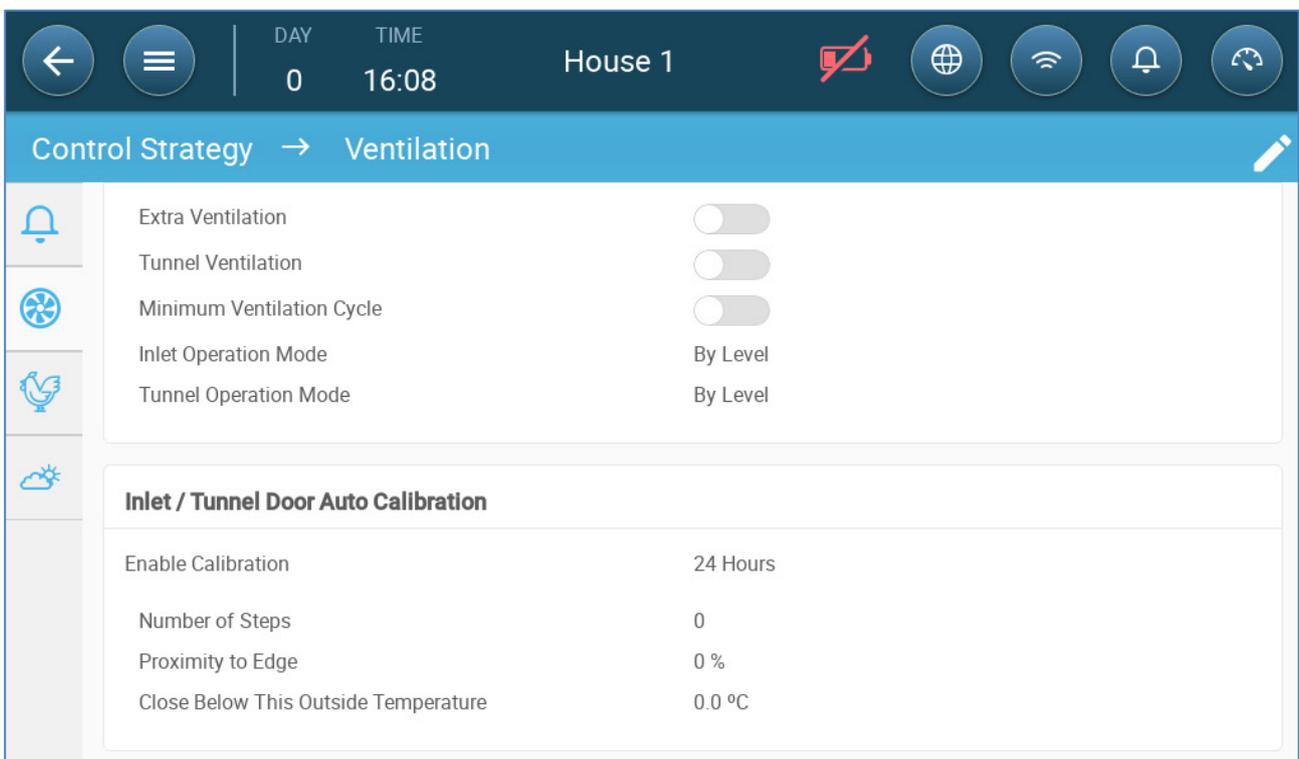

2. Click .

3. Define:

- Enable Calibration: Select 24 hours a day or define a specific time frame.
- Number of steps: Set up the number of steps (number of movements).
- Proximity to Edge: Inlets will open or close based on this proximity to the edge. For example, when set to 10%, the curtain closes when the opening is less than 10% and opens completely when the opening is greater than 90%.
- Close Below This Temp. (out): Inlets close when the outside temperature reaches this point.
- **Potentiometer-controlled calibration failure:** If calibration fails (during auto or power up calibration) in a potentiometer-controlled calibration, an error symbol appears in the Devices and Sensor screen.

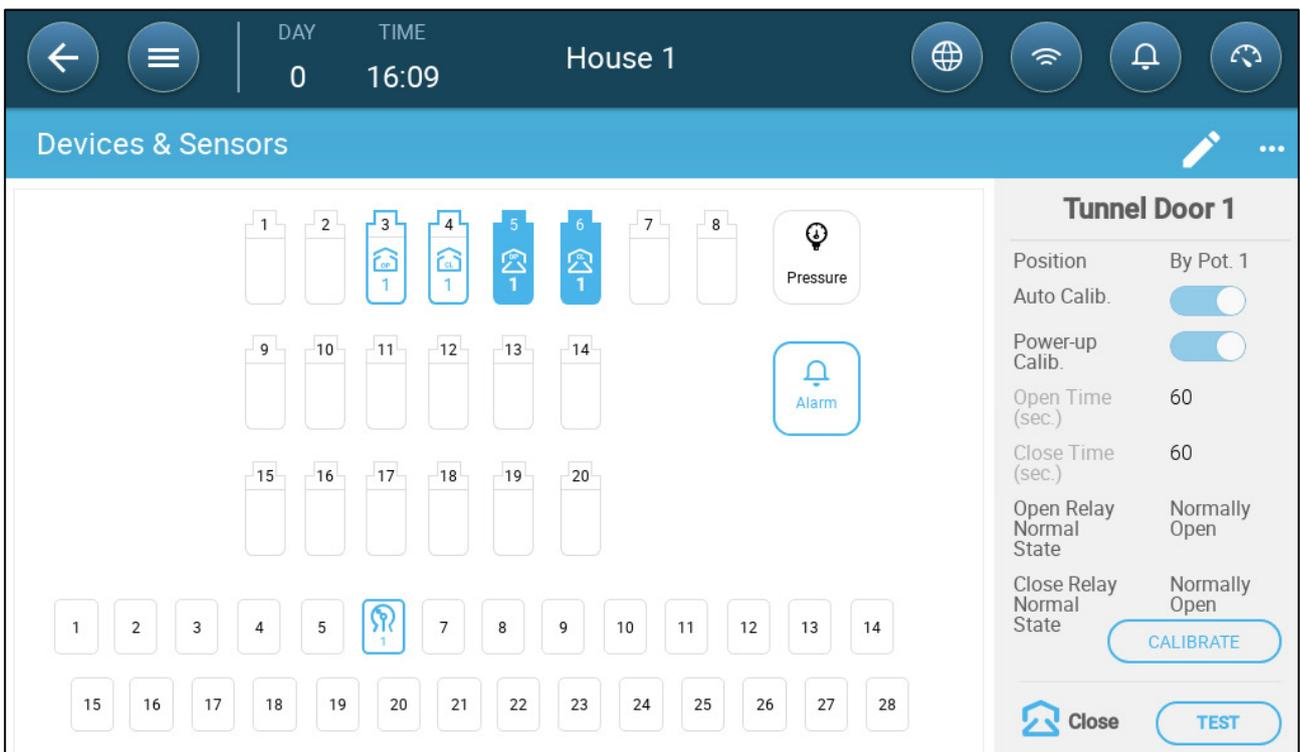

In this situation, click **Calibrate** to run the Calibration Wizard. If the calibration fails again, check:

- Potentiometer wiring
- Potentiometer
- Inlets' and curtains' opening and closing position. There must be a minimum distance between the two, equivalent to 300 A2D points.

8.7.3 DEFINING THE OUTLET

➤ Define one analog output port as an outlet (refer to Mapping Devices, page 48).

Outlet 1

| | |
|--------------|------|
| Min. Voltage | 0.0 |
| Max. Voltage | 10.0 |
| Open Time | 60 |
| Close Time | 60 |

🏠 10.0 TEST

- Define:
 - Min./Max Voltage: Define the voltage in the analogue output port that corresponds to the 0% and 100% output, respectively.
 - Open/Close Time: Enter the amount of time required to fully open or fully close the inlet.

8.8 Defining the Same As Relays

➡ Define up to 20 relays as Same as Relay (refer to Mapping Devices, page 48).

This function enables defining a relay to operate using the parameters defined for another relay. A relay can be tied to any other relay.

Same As Relay --

| | |
|-----------------|---------------|
| Related Channel | 0 |
| KWh | 0.0 |
| Operation | Normally Open |

 off TEST

- Define:
 - Related: Define which relay number to follow. Range: 1 – 20
 - KWh: This field displays the amount of kilowatts used. Read-only.
 - Operation: Define the relay mode.

8.9 Defining the Same As Analog Ports

- Define up to eight relays as Same as Analog Ports (refer to Mapping Devices, page 48).

This function enables defining a relay to operate using the parameters defined for a corresponding analog port. Relays can be mapped to eight specific ports only.

Same As Analog --

Related Channel None

KWh 0.0

Operation Normally Open

 off
TEST

- Define:
 - Related Chanel: Define which port number to follow.

| Port Number | Related Channel |
|-------------|-----------------|
| 7 | 1 |
| 8 | 2 |
| 9 | 3 |
| 10 | 4 |
| 21 | 5 |
| 22 | 6 |
| 23 | 7 |
| 24 | 8 |

- KWh: This field displays the amount of kilowatts used. Read-only.
- Operation: Define the relay mode.

8.10 Defining the Timer

➡ Define up to five relays as timers (refer to Mapping Devices, page 48).

Timer 1

KWh 0.0

Operation Normally
 Open

off **TEST**

- Define:
 - KWh: This field displays the amount of kilowatts used. Read-only.
 - Operation: Define the relay mode.

8.11 Defining the Auxiliary Input

- Define up to four digital inputs as auxiliary inputs (refer to Mapping Devices, page 48).

| Auxiliary Input 1 | |
|-------------------|---------------|
| Operation | Normally Open |
| Enable Mode | Enabled |

AUX off

- Define:
 - Operation: Define the relay mode.
 - Enable Mode: Enable/disable the input.

8.12 Lighting Devices

➤ Define up to four relays or analog ports as light relays and one sensor as a light sensor (refer to Mapping Devices, page 48).

- Defining the On/Off Lights
- Defining the Variable Lights
- Defining the Light Sensor

8.12.1 DEFINING THE ON/OFF LIGHTS

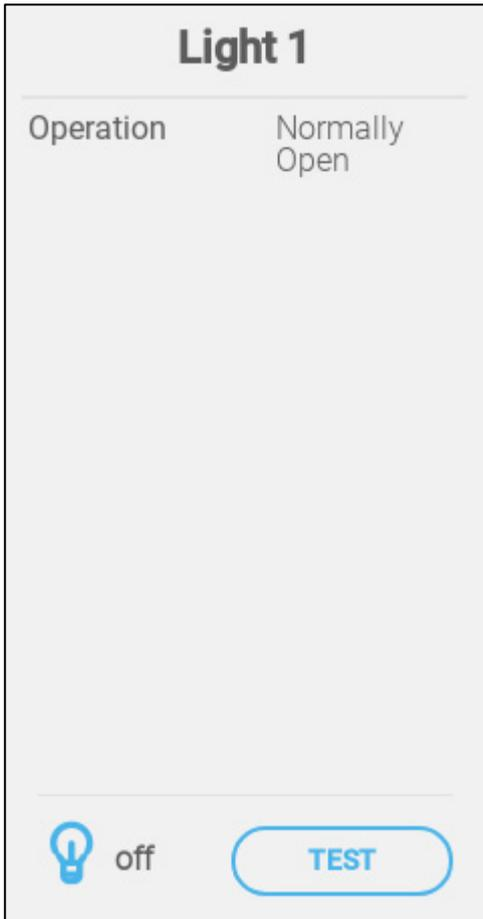

- Define:
 - Operation: Define the relay mode.

8.12.2 DEFINING THE VARIABLE LIGHTS

Light 4

| | |
|--------------|------|
| Min. Voltage | 0.0 |
| Max. Voltage | 10.0 |

 0.0

- Minimum/Maximum Voltage: Enter the minimal and maximal voltage used to calibrate the light strength.

8.12.3 DEFINING THE LIGHT SENSOR

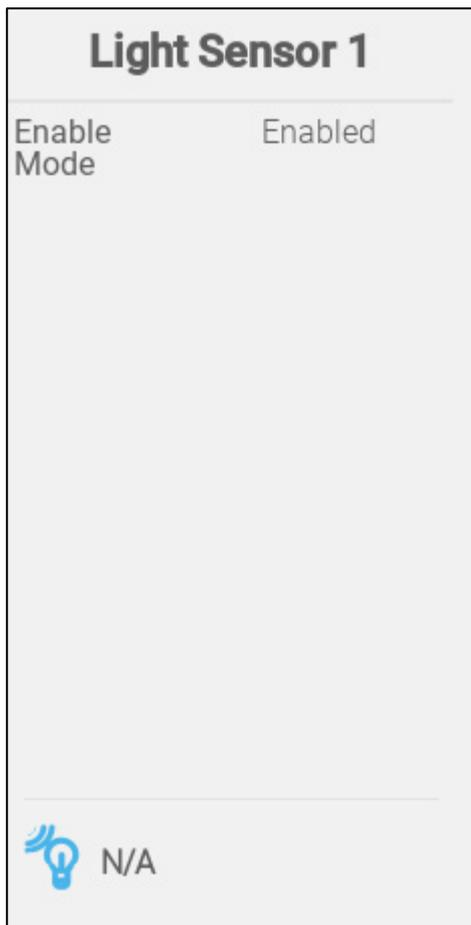

- Define:
 - Enable Mode: Enable/disable the sensor.

8.13 Feeding Devices

Setting up a feed system requires auger relays and sensors, and feeder relays and sensors. Define:

- Auger and feed relays to control the auger/feeder lines.
- Auger digital sensors to detect auger overtime issues: silo is empty, feed lines are stuck, or other mechanical issue.
 - Auger 1 is automatically associated with Augur Active Sensor 1. Auger 2 is automatically associated with Augur Active Sensor 2.
 - Feeder 1 active is associated to feeder 1 relay, feeder 2 active to feeder 2 relay, etc.
- Defining the Auger Relays
- Defining the Auger Active Sensors
- Defining the Feeder Relays
- Defining the Feeder Active Sensors

8.13.1 DEFINING THE AUGER RELAYS

➡ Define up to two relays as augers (refer to Mapping Devices, page 48).

Auger 1

| | |
|-----------|---------------|
| KWh | 0.0 |
| Operation | Normally Open |

 off TEST

- Define:
 - KWh: This field displays the amount of kilowatts used. Read-only.
 - Operation: Define the relay mode.

8.13.2 DEFINING THE AUGER ACTIVE SENSORS

➤ Define up to two digital ports as auger active (refer to Mapping Devices, page 48).

| Auger Active 1 | |
|---------------------|---------------|
| Operation | Normally Open |
| Quantity Per Minute | 0.0 |
| Enable Mode | Enabled |

 off

- Define:
 - Operation: Select if the relay is normally open or normally close.
 - Quantity Per Minute: Define the amount (weight per minute) of feed to be distributed.
 - Enable Mode: Enable or disable this sensor.

8.13.3 DEFINING THE FEEDER RELAYS

➤ Define up to four relays as feeders (refer to Mapping Devices, page 48).

Feeder 1

| | |
|-----------|---------------|
| KWh | 0.0 |
| Operation | Normally Open |

 off TEST

- KWh: This field displays the amount of kilowatts used. Read-only.
- Operation: Select if the relay is normally open or normally close.

8.13.4 DEFINING THE FEEDER ACTIVE SENSORS

- Define up to four digital input ports as feeder active (refer to Mapping Devices, page 48).

Feeder Active 1

| | |
|-------------|---------------|
| Operation | Normally Open |
| Enable Mode | Enabled |

 off

- Operation: Select if the relay is normally open or normally close.
- Enable Mode: Enable/disable the sensor.

8.14 Defining the Silos

- Mapping the Silo Scales
- Configuring the Silo Scale

8.14.1 MAPPING THE SILO SCALES

Trio can support up to two silo scales.

➔ This function requires a scale card.

1. On the Devices & Sensors screen, click Silo. The Scale icon turns brown.

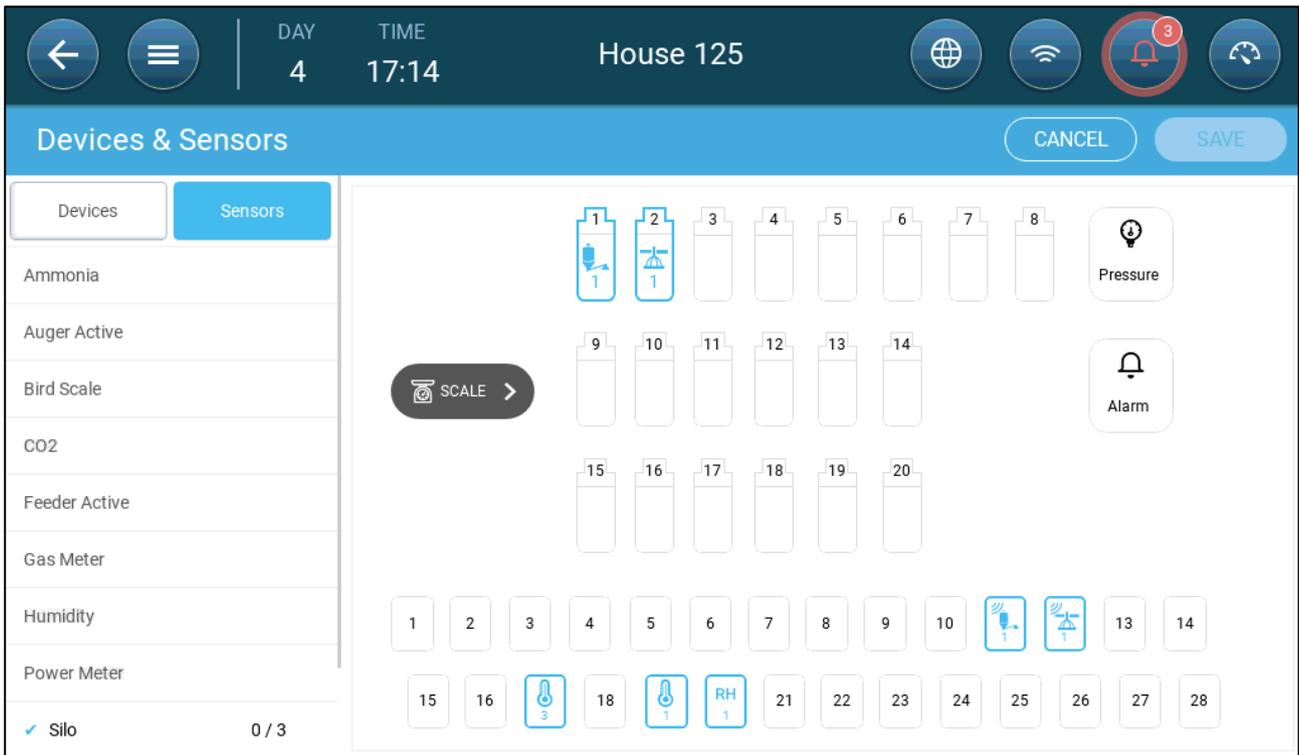

2. Click the Scale icon.
3. Select up to two channels and click Save.

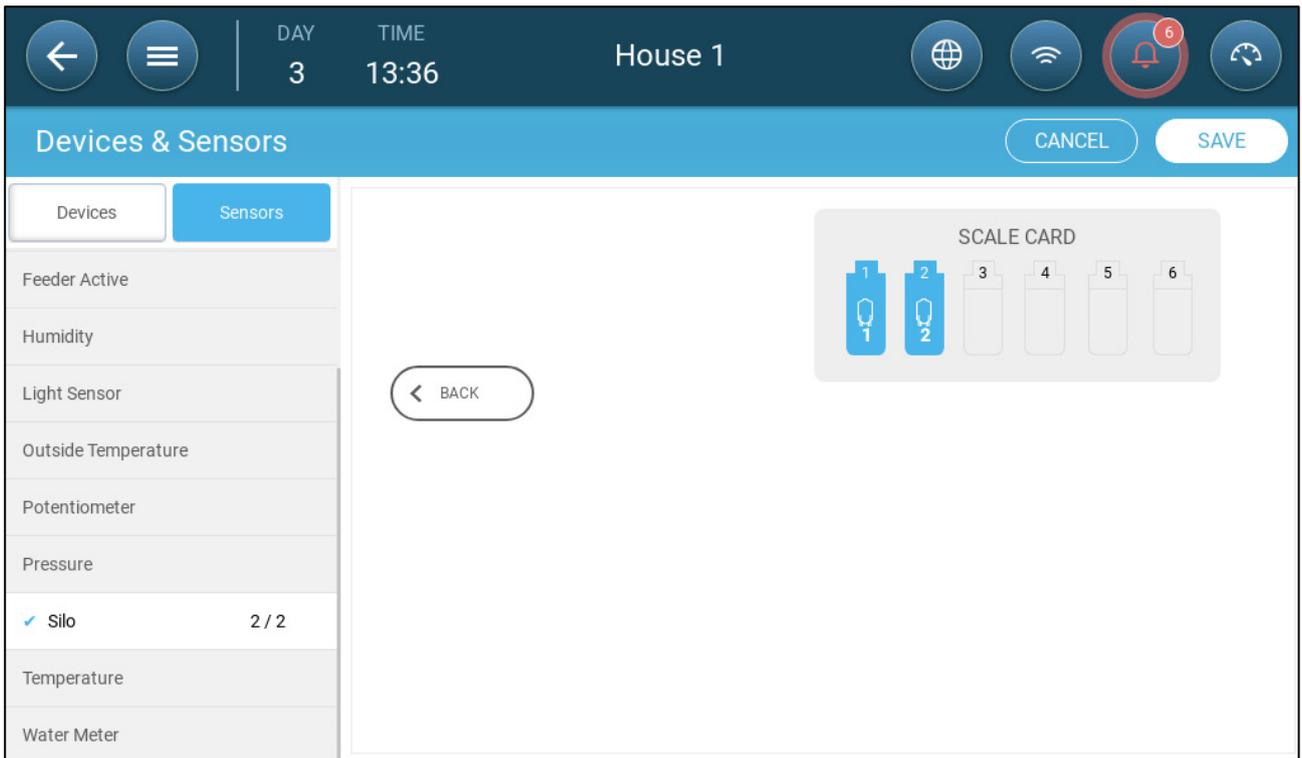

4. Click on each channel.

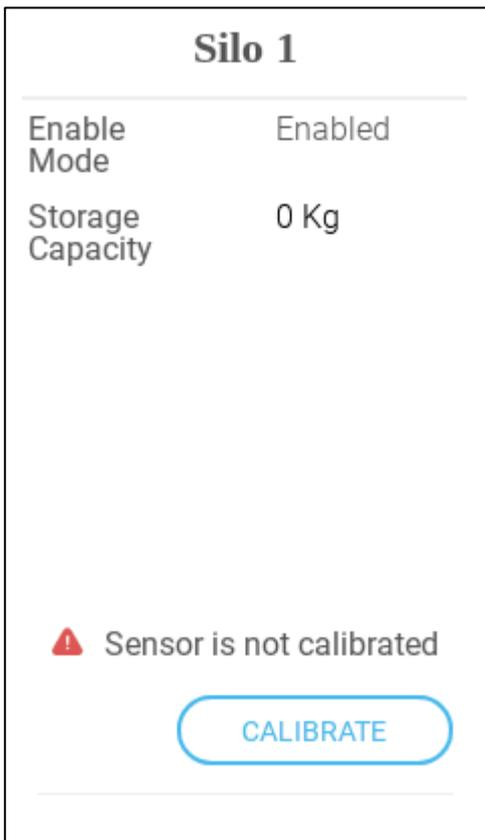

5. Define:

- Enable Mode: Enable/disable the channel.
- Storage Capacity: Define the quantity of feed that each silo can contain.
- Calibrate: Refer to the next section.

8.14.2 CONFIGURING THE SILO SCALE

The following procedure details how to “zero out” the Trio silo scales. Zeroing out is a way to ensure that the unit’s A2D number is accurate (shown in the Silo Icon; 430 in the picture below). To summarize the procedure:

- The user enters the correct amount of feed in the silo while calibrating the silo scale. In the Silo management screen, the user enters “0” (zero). Trio then defines the current A2D signal to be the A2D signal for an empty bin.

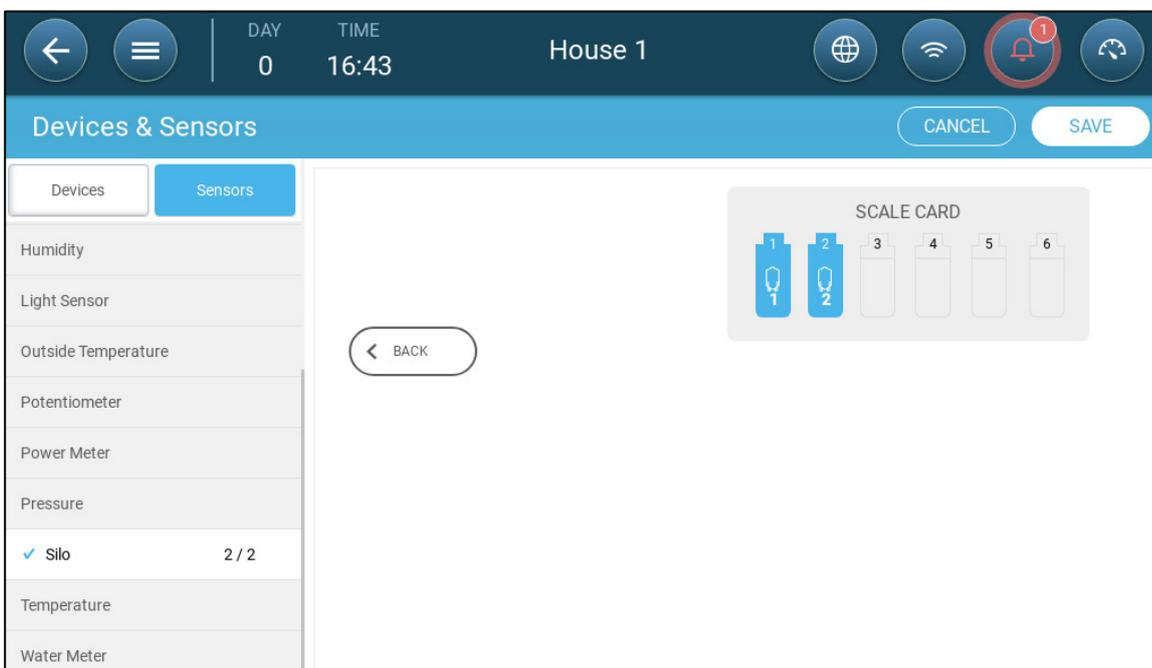
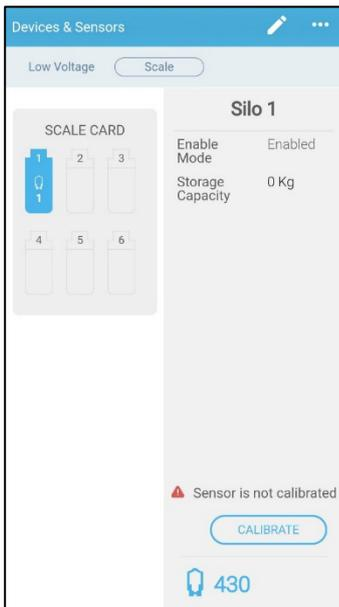

1. Define each silo’s storage capacity.
2. Click on the silo icon and click **Calibrate**. The following screen appears:

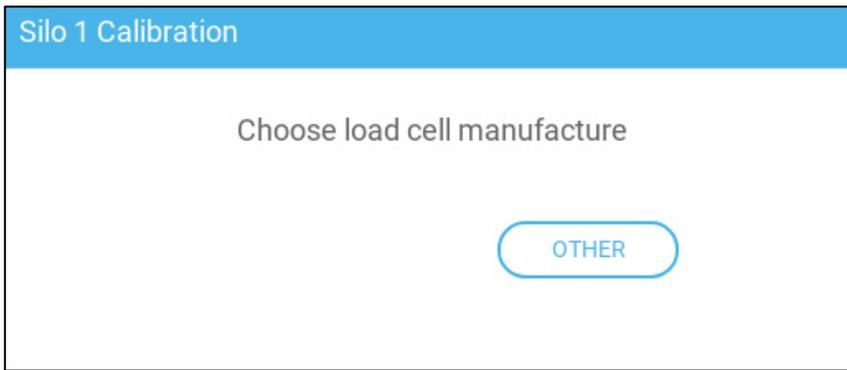

3. Click Other.

4. Fill up the silo with a known amount of feed. In this example, the silo contains 100 kilos of feed.

5. Enter the amount of feed in the silo and press Continue.

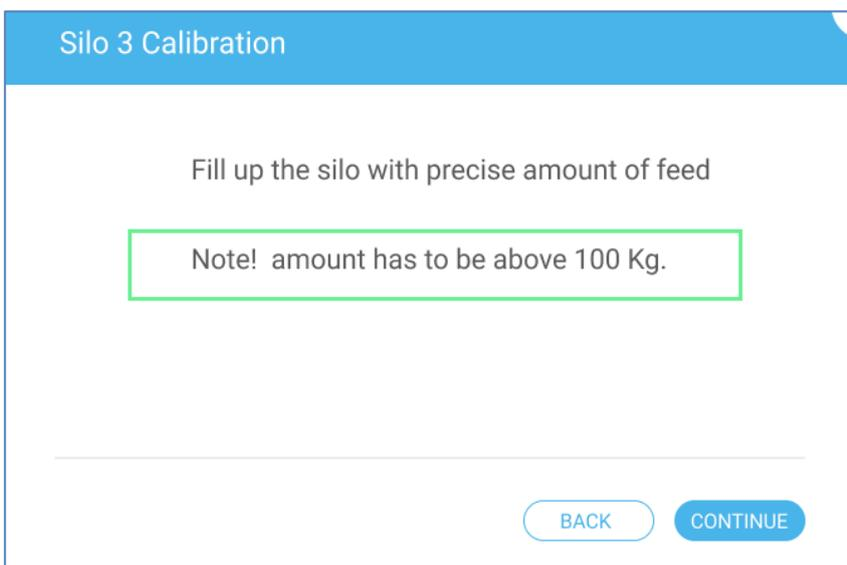

The following screen should appear.

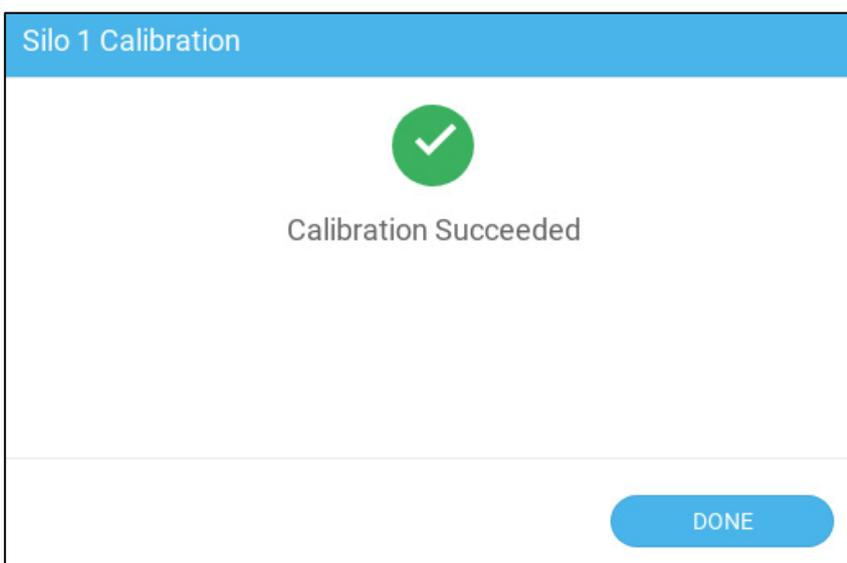

6. Go to Flock > Silo Management.

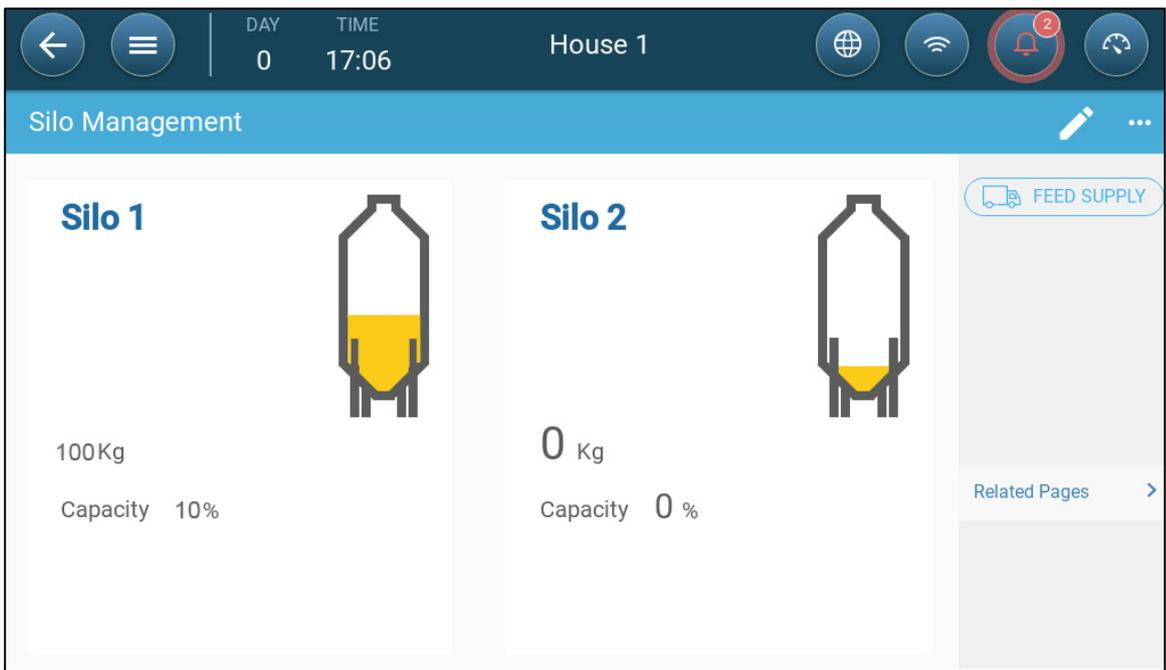

7. Click  and change the feed weight to 0.



8. Click **Save**.

The Trio now displays an accurate A2D number on the silo icon screen.

Silo 1

Enable Mode Enabled

Storage Capacity 1,000 Kg

CALIBRATE

 469

8.15 Defining the Bird Scales

- Mapping the Bird Scales
- Calibrating the Bird Scales
- Testing the Bird Scale

Trio can support up to four bird scales.

8.15.1 MAPPING THE BIRD SCALES

➡ Install a scale card.

1. On the Devices & Sensors screen, click Bird Scale. The Scale icon turns brown.

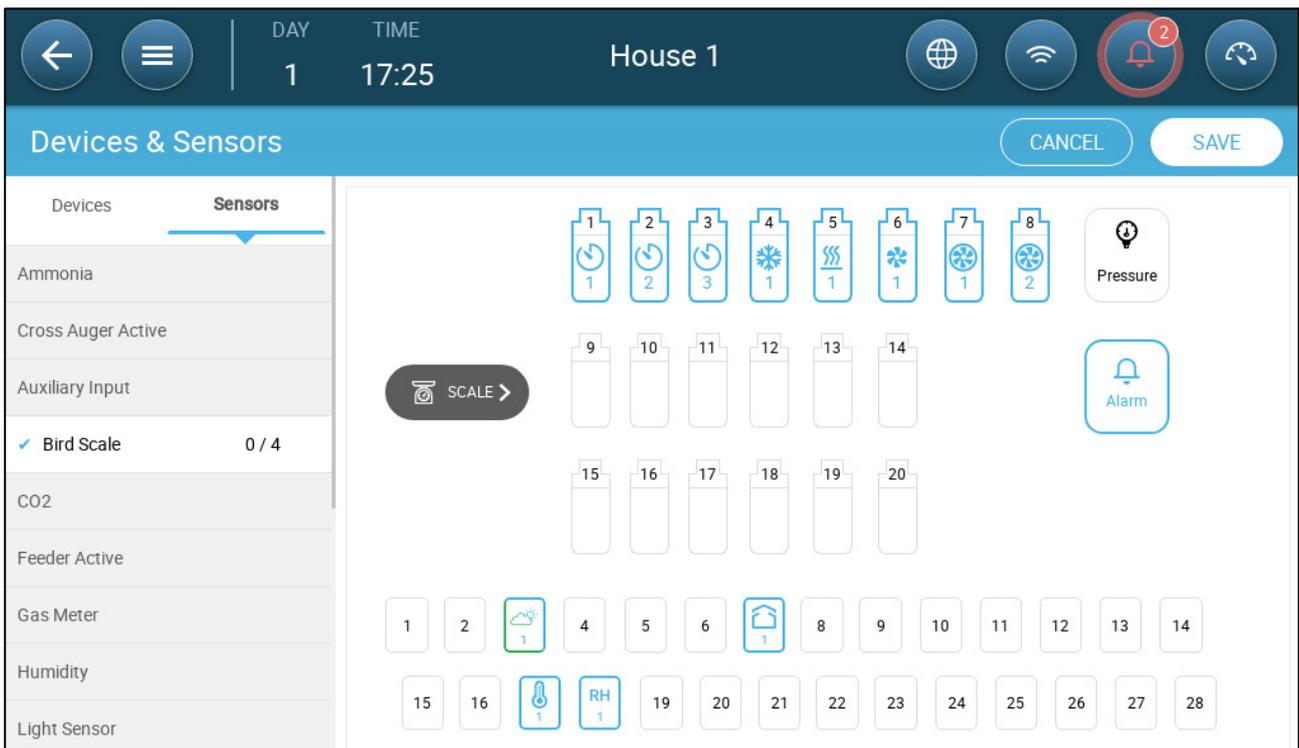

2. Click the Scale icon.

3. Define up to four channels as scales and click Save.

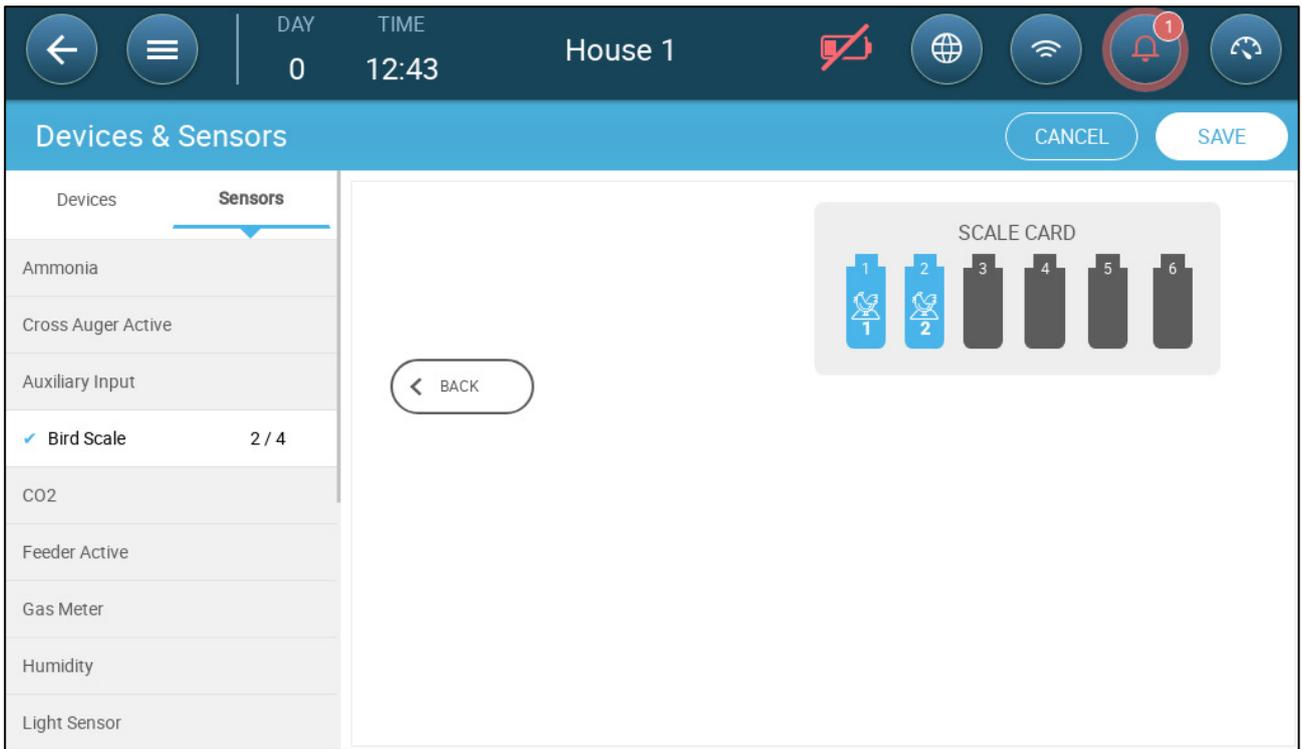

4. Verify that each channel is enabled.

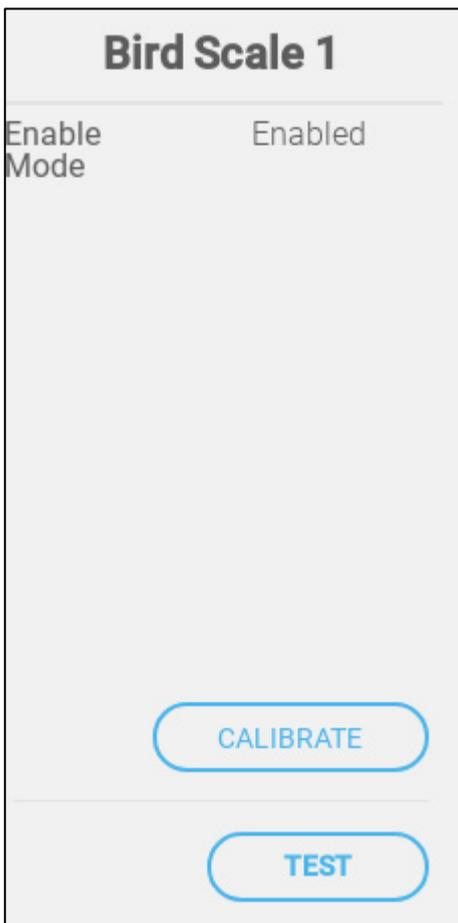

8.15.2 CALIBRATING THE BIRD SCALES

1. Click on a bird scale icon and click **Calibrate**. The following screen appears:

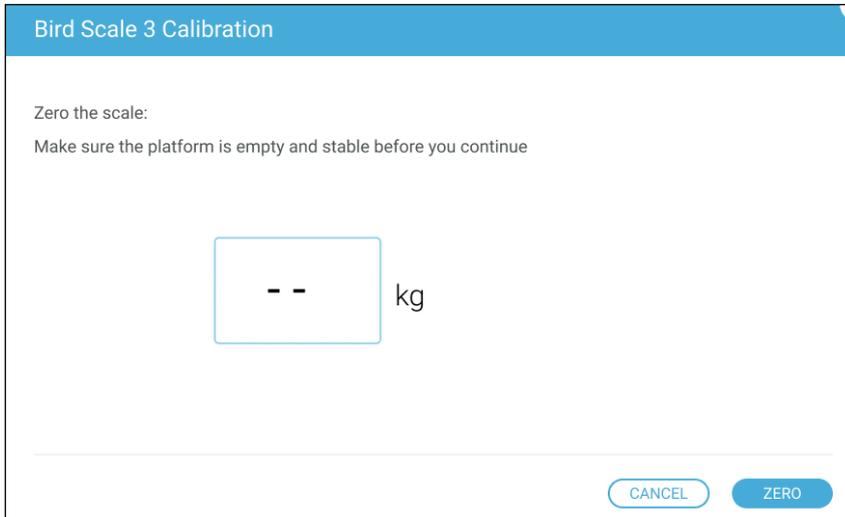

Bird Scale 3 Calibration

Zero the scale:
Make sure the platform is empty and stable before you continue

-- kg

CANCEL ZERO

This screenshot shows the 'Bird Scale 3 Calibration' interface. At the top, it says 'Bird Scale 3 Calibration'. Below that, it instructs the user to 'Zero the scale' and to 'Make sure the platform is empty and stable before you continue'. In the center, there is a digital display showing two dashes '--' followed by 'kg'. At the bottom right, there are two buttons: 'CANCEL' and 'ZERO'.

2. Remove everything from the scale and press **Zero**. In the following screen enter the weight being used to calibrate the scale; minimum is 1.0 kilogram. Click **Next**.

CAUTION The scale must be free of any objects before pressing **Next!**

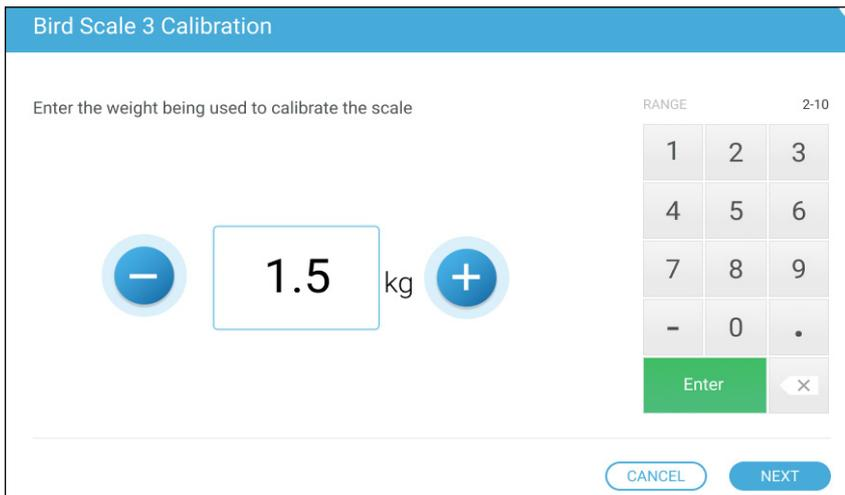

Bird Scale 3 Calibration

Enter the weight being used to calibrate the scale

RANGE 2-10

1 2 3
4 5 6
7 8 9
- 0 .
Enter X

- 1.5 kg +

CANCEL NEXT

This screenshot shows the 'Bird Scale 3 Calibration' interface. At the top, it says 'Bird Scale 3 Calibration'. Below that, it instructs the user to 'Enter the weight being used to calibrate the scale'. On the right, there is a numeric keypad with a 'RANGE 2-10' label. The keypad has buttons for digits 1-9, a minus sign, 0, and a decimal point. Below the keypad are 'Enter' and 'X' buttons. In the center, there is a digital display showing '1.5' followed by 'kg'. To the left of the display is a minus sign button and to the right is a plus sign button. At the bottom right, there are two buttons: 'CANCEL' and 'NEXT'.

3. Place a known weight on the scale (1.5 kilograms in the below example) and press **Next**.

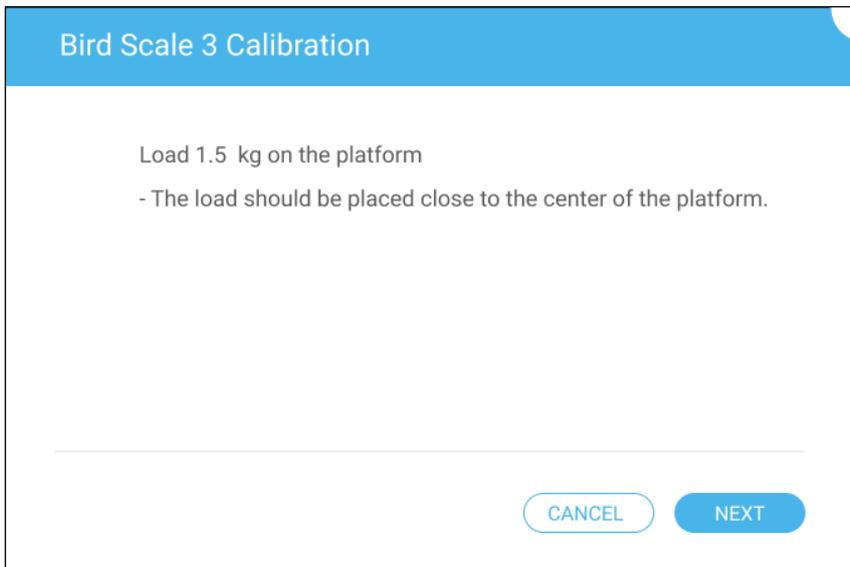

The following screen should appear:

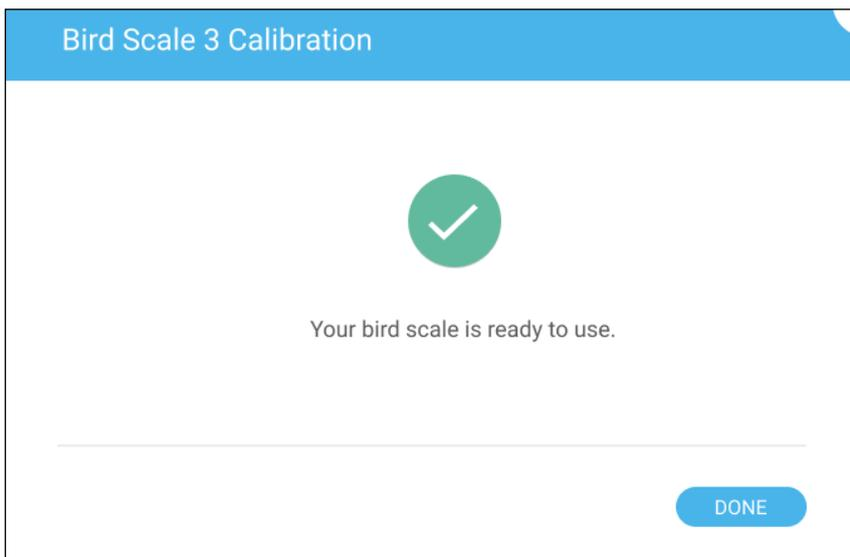

8.15.3 TESTING THE BIRD SCALE

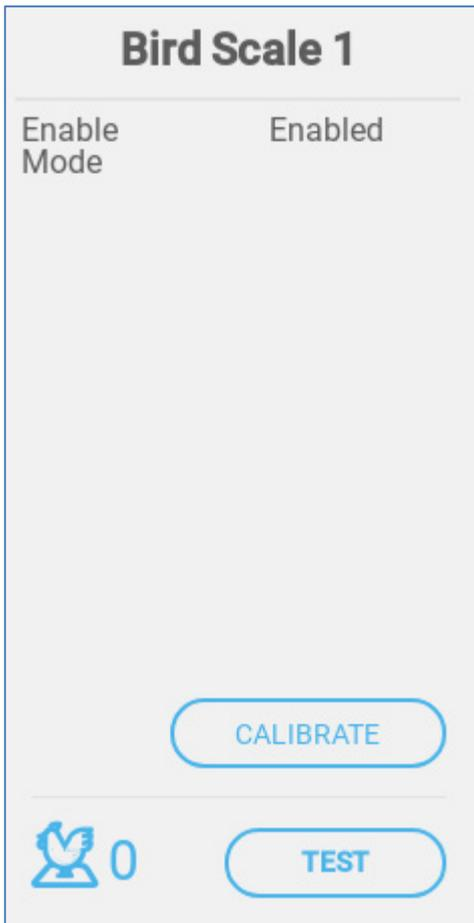

1. Click Test.

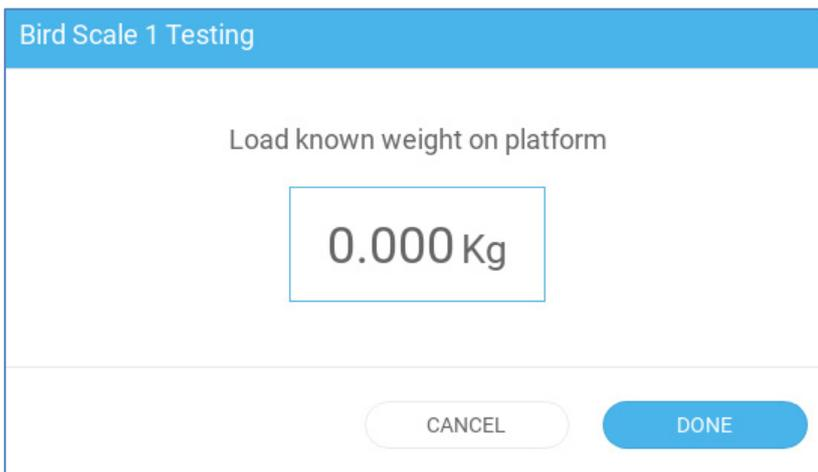

2. Place a known weight on the bird scale and click Done.
The result should be fairly close to the true weight.

8.16 Defining the RSU

The following section details how to define up to two RSU units connected to the Trio (optional). For detailed information on using the RSU, refer to the product manual.

➡ **Wire the RSU to the Trio as shown in Figure 32, page 36.**

1. Reset the Trio, as shown in General Settings > About.
2. Go to Device & Sensors > Installation > Scale.

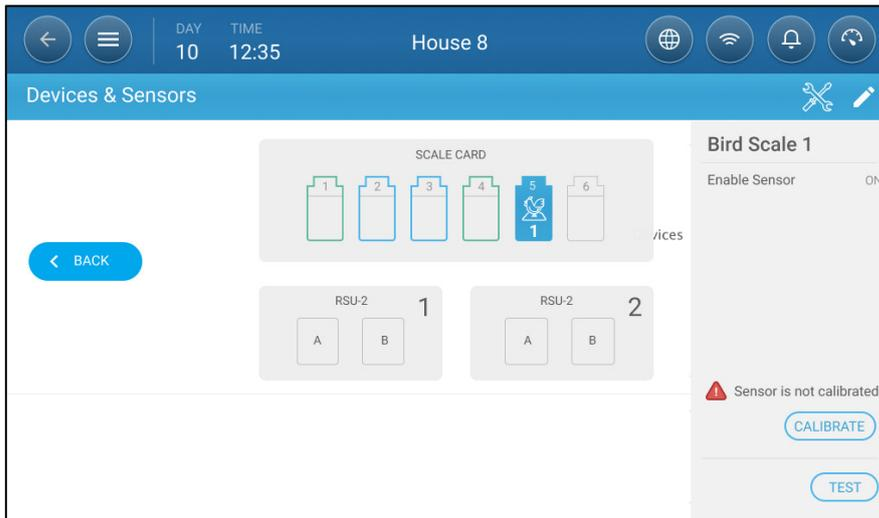

3. Click the RSU icon.
4. Click Calibrate.

Follow the instructions given in Configuring the Silo Scale, page 84.

8.17 Defining the Trio RPS

The following section details how to configure the RPS device.

- Define the Sensor
- Static Pressure Calibration

8.17.1 DEFINE THE SENSOR

1. Go to System > Devices & Sensors.

2. Click . The Devices & Sensor screen appears.

3. Click .

4. Click Pressure.

5. Define an analog input port as the pressure sensor. In the following screen, ports 5 is defined as the pressure sensor.

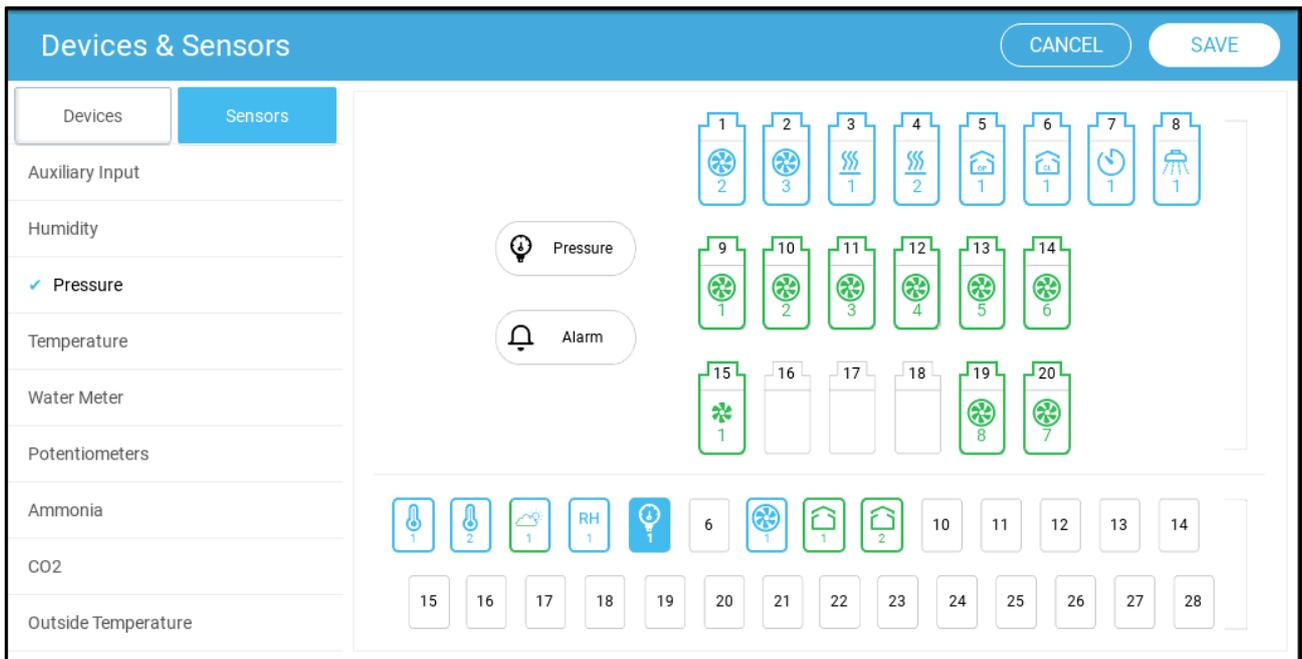

6. Go to Climate > Static Pressure and define the parameters.

8.17.2 STATIC PRESSURE CALIBRATION

CAUTION The Static Pressure sensor is factory calibrated. Only calibrate the sensor if you have reason to believe that they are producing inaccurate results.

The Static Pressure should be 0 when there is no ventilation and the house is closed. When the controller A/D counts is 100, this means that there is zero (0) static pressure.

NOTE: Run the controller for a few hours so that the temperature in the box becomes stable and only then calibrate.

CAUTION DO NOT blow the air into the hose to see if the pressure changes! The sensor is sensitive and blowing air can cause irreparable damage.

To calibrate the Static Pressure Sensor:

1. Disconnect the air hoses.
2. Go to System > Device & Sensors > Pressure.

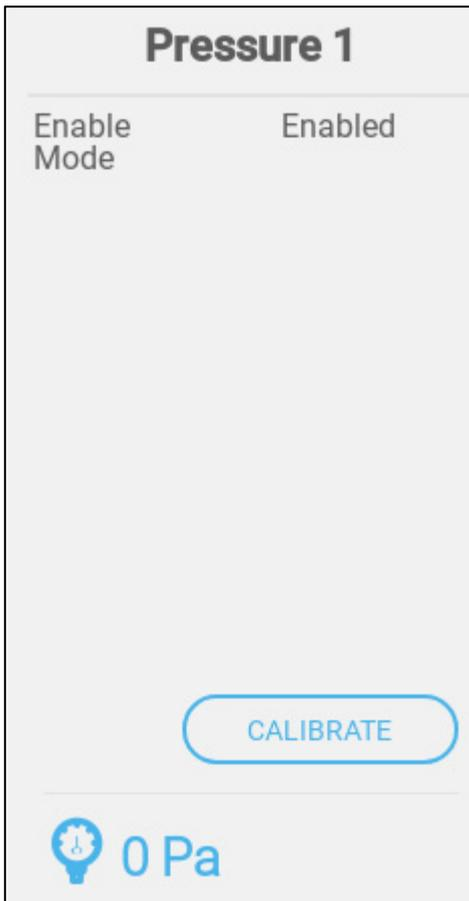

3. Click Calibrate.

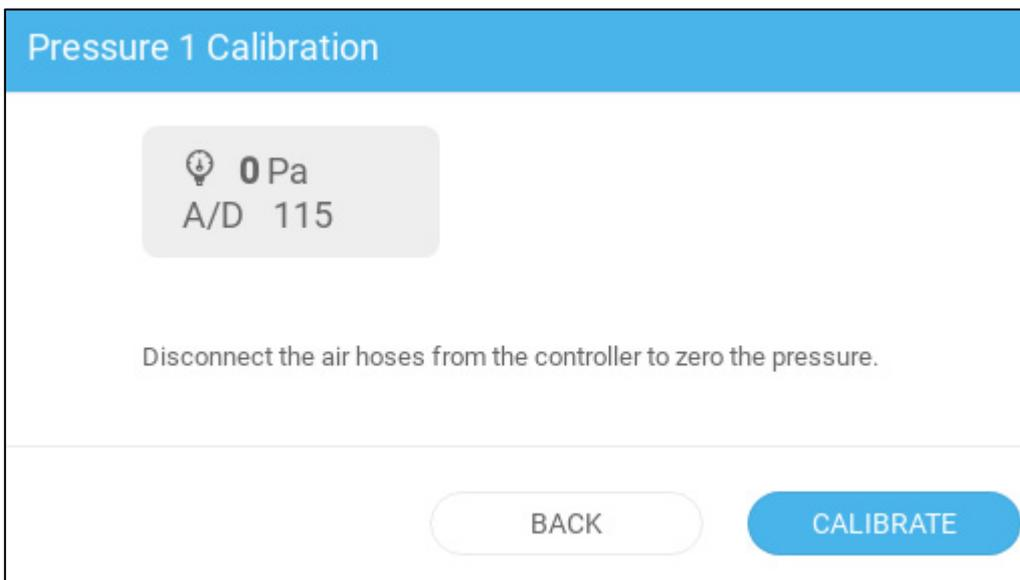

4. If the A/D count is 100 +/- 30 (70 to 130), click **Calibrate**.

5. If the A/D count is less than 70 or greater than 130:

- a. Check for blocked air hoses or wind interference.
- b. Open the Trio. On the Main Board, find the Static Pressure Sensor.

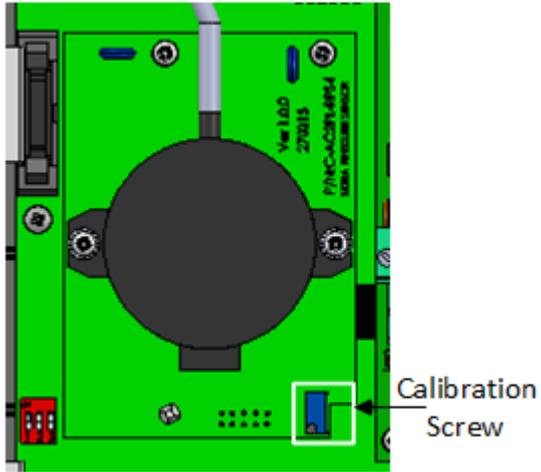

- c. Adjust the zero-pressure reading to approximately 100 by turning the calibration screw.
- d. When the A/D count is within the permitted range, press **Calibrate**.

9 Appendix A: External Devices (Previous Versions)

The following section details the relays and analog/digital ports found in previous software versions.

Table 4: Trio 20 Poultry STD - Version 4

| Name | Output | | | Measurements | |
|-----------------------|--------|-------|-------|--------------|---------|
| | Total | Relay | 0-10V | Analog | Digital |
| Cooling | 2 | 2 | | | |
| Heaters | 6 | 6 | 6 | | |
| Inlets | 2 | 2 | 2 | | |
| Outlets | 1 | NA | 1 | | |
| Tunnel Doors/Curtains | 2 | 2 | 2 | | |
| Fans Exhaust/Tunnel | 20 | 20 | 8 | | |
| Stir Fan | 1 | 1 | 1 | | |
| Timer | 5 | 5 | | | |
| Auger | 2 | 2 | | | |
| Feeder | 4 | 4 | | | |
| Lighting | 4 | 4 | 4 | | |
| As Relay | 30 | 30 | NA | | |
| As Analog Output | 8 | NA | 8 | | |
| Alarm | 1 | 1 | | | |
| Temperature Sensors | | | | 12 | |
| Humidity Sensors IN | | | | 1 | |
| CO2 Sensors | | | | 1 | |
| Ammonia Sensors | | | | 1 | |
| Pressure Sensors | | | | 1 | |
| Potentiometers | | | | 4 | |
| Power Meter | | | | 2 | |
| Gas Meter | | | | 2 | |
| Lux Meter | | | | 1 | |
| Bird Weighing | | | | 2 | |
| Silo Weighing | | | | 2 | |
| Water Meters | | | | | 1 |
| Aux. Input | | | | | 4 |
| Auger Sensor | | | | | 2 |
| Feeder Line Sensor | | | | | 4 |

Table 5: Trio 20 Poultry STD - Version 3

| Name | Output | | | Measurements | |
|-----------------------|--------|-------|-------|--------------|---------|
| | Total | Relay | 0-10V | Analog | Digital |
| Cooling | 2 | 2 | | | |
| Heaters | 4 | 4 | 4 | | |
| Inlets | 2 | 2 | 2 | | |
| Outlets | 1 | NA | 1 | | |
| Tunnel Doors/Curtains | 2 | 2 | 2 | | |
| Fans Exhaust/Tunnel | 12 | 12 | 8 | | |
| Stir Fan | 1 | 1 | 1 | | |
| Timer | 5 | 5 | | | |
| Auger | 2 | 2 | | | |
| Feeder | 4 | 4 | | | |
| Lighting | 4 | 4 | 4 | | |
| As Relay | 20 | 20 | NA | | |
| As Analog Output | 8 | NA | 8 | | |
| Alarm | 1 | 1 | | | |
| Temperature Sensors | | | | 12 | |
| Humidity Sensors IN | | | | 1 | |
| CO2 Sensors | | | | 1 | |
| Ammonia Sensors | | | | 1 | |
| Pressure Sensors | | | | 1 | |
| Potentiometers | | | | 4 | |
| Power Meter | | | | X | |
| Gas Meter | | | | X | |
| Lux Meter | | | | 1 | |
| Bird Weighing | | | | 2 | |
| Silo Weighing | | | | 2 | |
| Water Meters | | | | | 1 |
| Aux. Input | | | | | 4 |
| Auger Sensor | | | | | 2 |
| Feeder Line Sensor | | | | | 4 |

10 Appendix B: Service Manual

- Maintenance
- Trouble Shooting
- Spare Parts

10.1 Maintenance

Perform the following steps to maintain your unit.

- Checking the Battery Level: Check the battery once a year. The output must be 2.7 volts (minimum). Authorized personnel only must replace the battery if the output is below the minimum required level or every five years.
- Visually inspect your unit once a year. Make sure that there are no signs of corrosion or residue on the PCBs. If these issues appear, it means that:
 - the Trio is installed in an environment with high humidity, ammonia content, or some other destructive agent.
 - There is a lack of (silicon) sealing or that the sealing has degraded.
- Make sure that the silicon seal around the PGs installed in the knockouts is not cracked.
- Check that the gasket is not cracked.

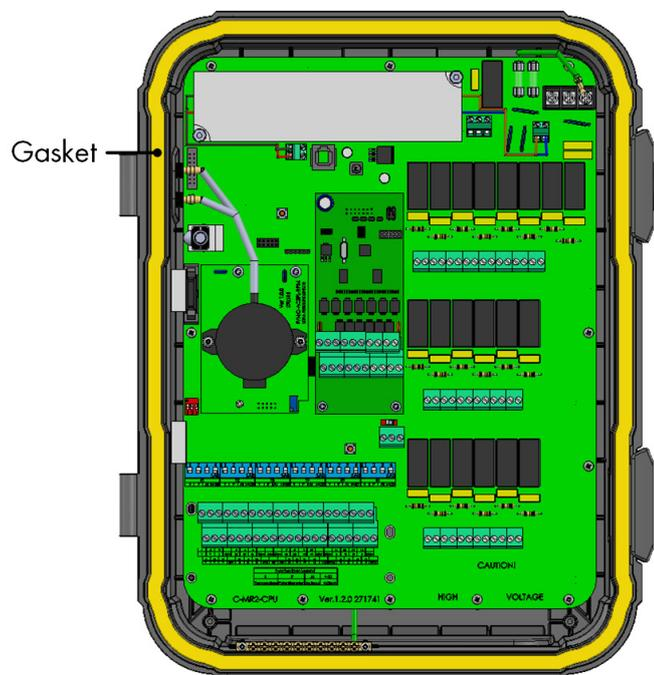

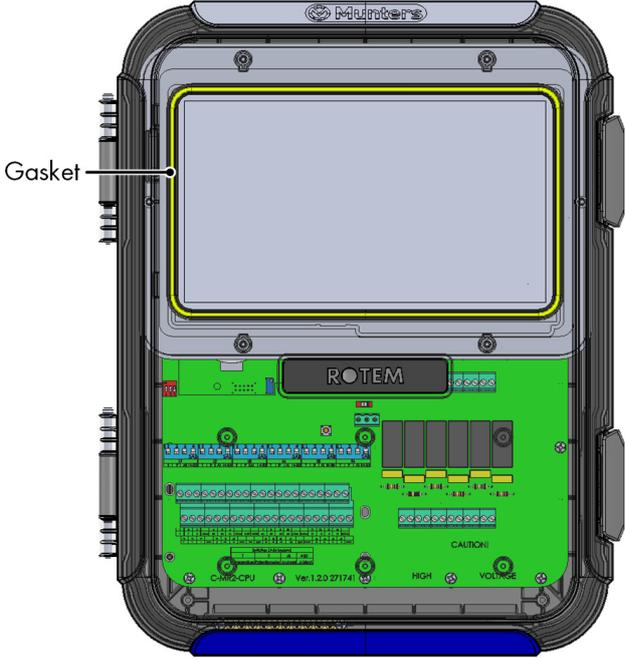
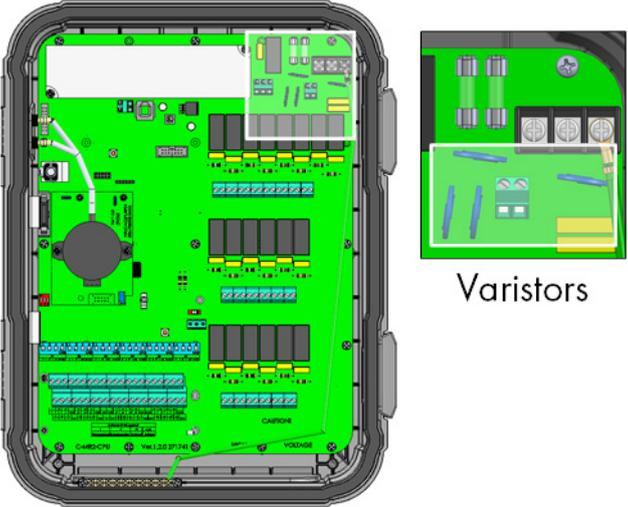
| | |
|--|---|
| <ul style="list-style-type: none"> • Check that the gasket around the touch screen is not cracked. |  |
| <ul style="list-style-type: none"> • Look for any signs of burns or browning around the varistors. |  |
| <ul style="list-style-type: none"> • Inspect the shield wiring and main grounding cable; ensure that they are properly connected to the proper ports. | |

10.2 Trouble Shooting

- Internet
- Electronic Components

10.2.1 INTERNET

The following section describes how to trouble shoot internet problems. In the event that there is no internet connection:

1. Go to System > General Settings > Network Screen. Verify that there is an IP address.
2. Check the cable connections between the switch and the Trio.
3. Verify that the unit is powered.

NOTE If there is no internet connection, the Main Menu Internet icon is marked.



10.2.2 ELECTRONIC COMPONENTS

Problem: The touch screen doesn't turn on up after applying 115/230VAC.

Solution: Open the Trio door and:

1. Check main 115/230VAC 3A fuse F2.
 - If required, replace the fuse.
2. Check the 12V terminal voltage (COM & 12V).
 - If there is no voltage, there is a problem with the Switched Power Supply. Replace the power supply.
3. Verify that the 5V and 3.3V indicative LEDs of the I/O power board are lit.
4. Verify that the flat cable connecting the I/O board and the display board is in place.
5. Verify that the Green Status LED is flashing.
6. On the Trio display board, verify that the:
 - RED Status LED is flashing.
 - Display's flat cable is firmly hooked up to its connector.

Problem: The screen doesn't reflect changes made in the analog inputs.

Solution:

1. Verify that the position of Dip Switch (S1-S6) corresponds with the relevant analog input.
2. Verify that the analog input terminals' mapping corresponds to the actual wiring.
3. Check that the terminal wire connection of Analog Input of interest coincides with the analog input chosen on the touch screen.

Problem: The screen doesn't reflect the changes in digital inputs.

Solution: Verify that the digital input terminals' mapping corresponds to the actual wiring.

Problem: The Alarm Relay doesn't operate.

Solution: Check fuse F4.

- By default, alarm relay contacts "NO-COM" should be closed.

Problem: The analog output voltage doesn't correspond to the voltage defined on the corresponding analog output terminal.

Solution: Check the load value. The maximum analog output load is 15 mA.

Problem: An analog output terminal has no output voltage.

Solution: Verify that the analog output terminals' mapping corresponds to the actual wiring.

Problem: The display screen appears but does not respond to any touch.

Solution: Check the USB cable between the touch screen card and the Trio display card.

Problem: There is no 3.3V output for to power the potentiometer(s).

Solution: There is a PPTC fuse F1 on the 3.3V line. Disconnect the potentiometers and using a DVM, check the resistance on the terminal between the 12V output and common ground (COM). The reading should indicate an open circuit.

- If not, the line is damaged.

Problem: The end user doesn't see changes in the data tables.

Solution:

1. Check the Internet cable, going from RJ-45 connector (marked as Ethernet-2). Verify that the connector's LEDs are flashing.
2. Check the Internet cable, going from the power card to the Trio display's card RJ-45 connector (marked as Ethernet-1). Verify that the connector's LEDs are flashing.

10.3 Spare Parts

- Preliminary Information
- Trio 20 Container Spare Parts
- Trio 20 Door Card Spare Parts
- Trio 20 Main Container Spare Parts
- Additional Options
- Cards

10.3.1 PRELIMINARY INFORMATION

| | Trio 20 |
|----------------------|---------------------|
| Container | A |
| Door Cards | B |
| Main Container Cards | C |
| Cables and Harnesses | D |
| MPN | Munters Part Number |
| DPN | Dealer Part Number |

10.3.2 TRIO 20 CONTAINER SPARE PARTS



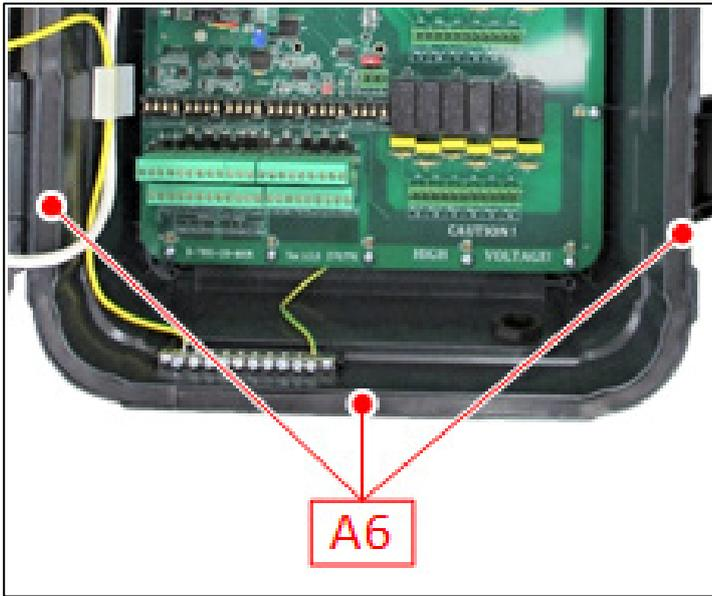

| ID No. | Description | Order Catalog Number | Note |
|-------------|---|---------------------------|------|
| A1.1 | Trio-20 FRONT DOOR TOUCH PLASTIC PART | MPN: 940-99-00005 DPN: | |
| A1.2 | Trio-20 PLASTIC BOX BASE | MPN: 940-99-00007 DPN: | |
| A1.3 | Trio HINGE PLASTIC PIN V1.0.0 (SP-207128) | MPN: 940-99-00019 DPN: | |
| A2.1 | Trio-20 PANEL PLASTIC PART BLUE LOGO MUNTERS + PART BLUE | MPN: 940-99-00001 DPN: | OR |
| A2.2 | Trio PANEL PLASTIC PART RED RAL 3020 NO LOGO (SP-207138) | MPN: 940-99-00045 DPN: | |
| A3.1 | ONE / ONE PRO - LATCH GENERAL LOCK PLASTIC PART + LOCK FOR LATCH | MPN: 900-99-00217 DPN: | |
| A3.2 | GENERAL PLASTIC LATCH | MPN: 900-99-00216 DPN: | |
| A4 | Trio-20 LCD HOLDER V1.0.0 (SP-207125) | MPN: 940-99-00024 DPN: | |
| A5 | P4 SCREEN GASKET SILICONE 35 SHORE 75CM (EXTRUSION PROCESS) (SP-204079) | MPN: 940-99-00020 DPN: | |
| A6 | MID-RANGE MAIN GASKET V1.0.0 (SP-207122) | MPN: 940-99-00021 DPN: | |

10.3.3 TRIO 20 DOOR CARD SPARE PARTS

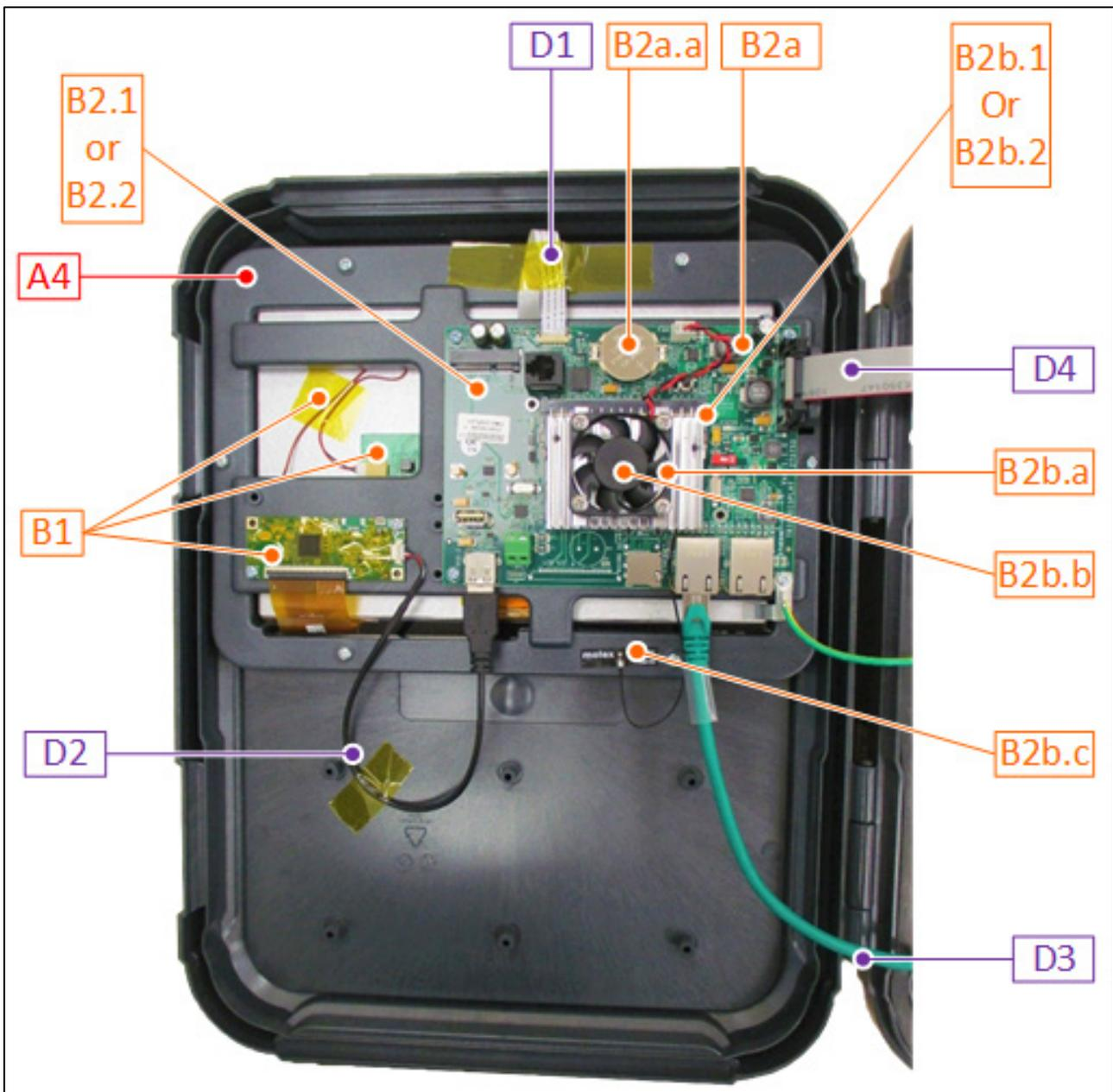

| ID No. | Description | Order Catalog Number | Note |
|--------------|--|----------------------|------------|
| B1 | Trio-20 LCD KIT (DISPLAY + LVDS CARD), [+ USB CABLE *] | MPN: 940-99-00002 | |
| | | DPN: | |
| B2.1 | Trio 20 -POU- DISPLAY CARD AND SOM VARISCITE CARD WITH HEATSINK AND FAN | MPN: 940-99-00034 | OR |
| | | DPN: | |
| B2.2 | Trio 20 -POU-CN- DISPLAY CARD AND SOM VARISCITE CARD WITH HEATSINK AND FAN | MPN: 940-99-00032 | CHINA ONLY |
| | | DPN: | |
| B2a | Trio 20 DISPLAY CARD (Trio-DISPLAY) | MPN: 940-99-00004 | |
| | | DPN: | |
| B2a.a | BAT COIN 3V FOR SOCKET(SP-450009) | MPN: 999-99-00386 | |
| | | DPN: | |
| B2b.1 | Trio 20 -POU- SOM VARISCITE CARD WITH HEATSINK AND FAN | MPN: 940-99-00008 | OR |
| | | DPN: | |
| B2b.2 | Trio 20 -POU-CN- SOM VARISCITE CARD WITH HEATSINK AND FAN | MPN: 940-99-00044 | CHINA ONLY |
| | | DPN: | |
| B2b.a | Trio 20 HEATSINK AND FAN FOR SOM CARD | MPN: 940-99-00026 | |
| | | DPN: | |
| B2b.b | FAN FOR Trio SOM CARD (SP-204152) | MPN: 940-99-00025 | |
| | | DPN: | |
| B2b.c | Trio 20 ANTENNA WIFI MOLEX 15cm CABLE U.FL/I-PEX MHF 2.4GHz 2.8dBi 50ohm (SP-491009) | MPN: 940-99-00035 | |
| | | DPN: | |

| ID No. | Description | Order Catalog Number |
|-----------|--|----------------------|
| D1 | VIDEO FLAT CABLE 0.02" (0.50 mm) Type 1,152.4 mm | MPN: 940-99-00012 |
| | | DPN: |
| D2 | USB CABLE FOR Vitek\Ampire DISPLAY (SP-140672) | MPN: 940-99-00027 |
| | | DPN: |
| D3 | NETWORK CABLE RJ485 (8 WIRES, 0.5 METERS) | MPN: 940-99-00011 |
| | | DPN: |
| D4 | FLAT FF14P 25CM F"D>_V1.0.0 (SP-141161) | MPN: 999-99-00457 |
| | | DPN: |

10.3.4 TRIO 20 MAIN CONTAINER SPARE PARTS

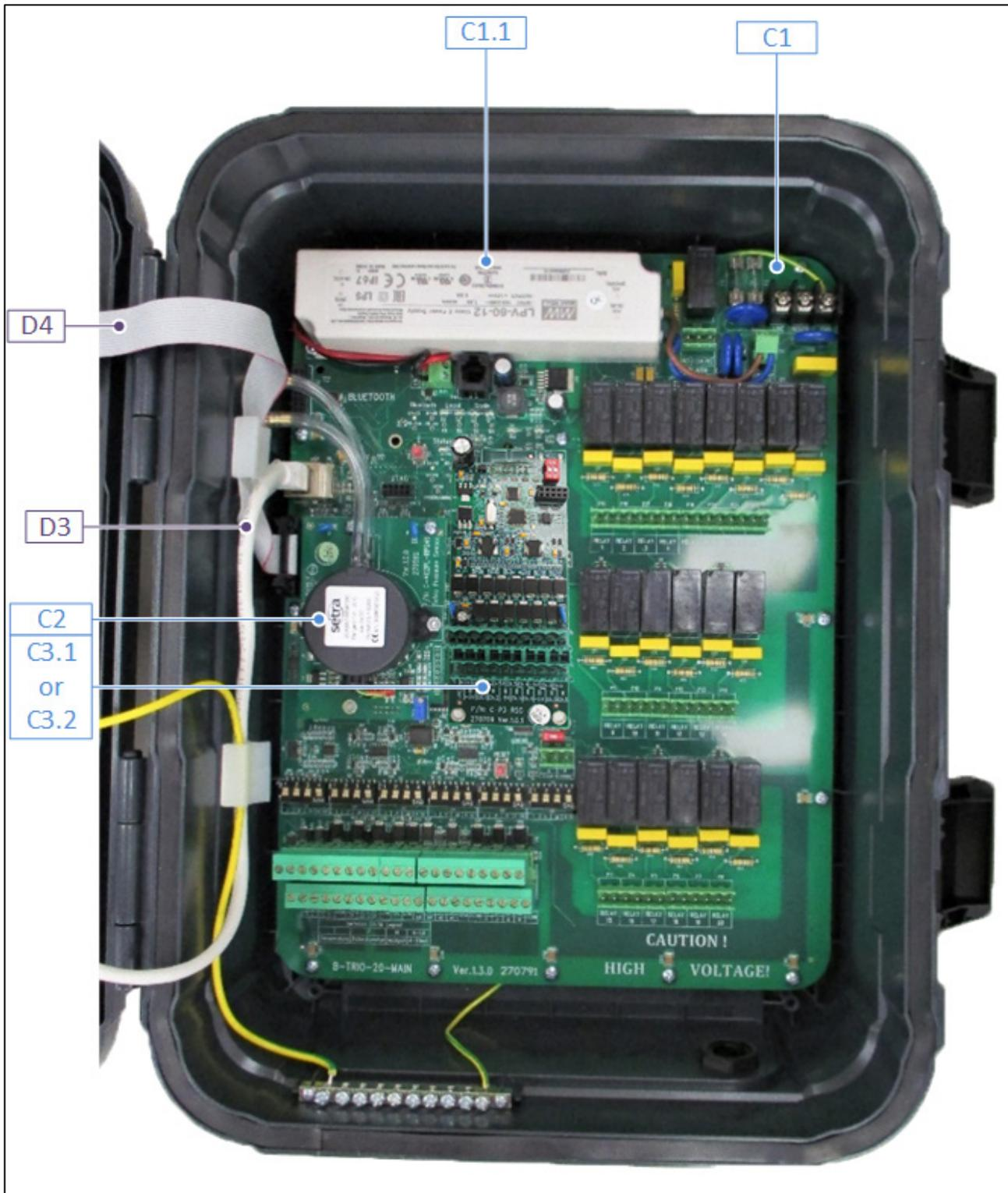

| ID No. | Description | Order Catalog Number | Remarks |
|--------|--|----------------------|---------|
| C1 | Trio-20 MAIN CARD (Trio-20 MAIN) | MPN: 940-99-00003 | |
| | | DPN: | |
| C1.1 | SWPS LPV-60-12 Mean Well 100-240V 12V 60W (SP-370193) | MPN: 900-99-00264 | |
| | | DPN: | |
| C2 | STATIC PRESSURE SET - AC3G / SE / PL / Trio - POU (WITH EXTERNAL TUBE) | MPN: 901-99-00025 | |
| | | DPN: | |
| C3.1 | Trio 20 SCALE CARD 2SCL (Trio-RSC-2) | MPN: 940-99-00013 | OR |
| | | DPN: | |
| C3.2 | Trio 20 SCALE CARD 2SCL (Trio-RSC-6) | MPN: 940-99-00014 | |
| | | DPN: | |



| ID No. | Description | Order Catalog Number | Remarks |
|--------|-----------------------------------|----------------------|---------|
| C4 | BAT COIN 3V FOR SOCKET(SP-450009) | MPN: 999-99-00386 | |
| | | DPN: | |

10.3.5 ADDITIONAL OPTIONS

| ID No. | Description | Order Cat. No. | Remarks |
|---------|--|-------------------|---------|
| ADO 1 | TEMPERATURE SENSOR BLACK-RTS-2-POU | MPN: 918-01-00001 | |
| | | DPN: | |
| ADO 2 | HUMIDITY SENSOR-RHS-POU-ROT-SE-10PL | MPN: 917-02-00003 | |
| | | DPN: | |
| ADO 3 | STATIC PRESSURE SET - AC3G/SE/PL/Trio - POU | MPN: 901-99-00025 | |
| | | DPN: | |
| ADO 3.a | TUBES AND FILTERS FOR RPS (NO RPS CARD) | MPN: 999-99-00503 | |
| | | DPN: | |
| ADO 4.1 | Trio 20 SCALE CARD 2SCL WITH 230V POWER SUPPLY | MPN: 940-99-00015 | OR |
| | | DPN: | |
| ADO 4.2 | Trio 20 SCALE CARD 6SCL WITH 230V POWER SUPPLY | MPN: 940-99-00016 | OR |
| | | DPN: | |
| ADO 4.3 | Trio 20 SCALE CARD 2SCL WITH 115V POWER SUPPLY | MPN: 940-99-00017 | OR |
| | | DPN: | |
| ADO 4.4 | Trio 20 SCALE CARD 6SCL WITH 115V POWER SUPPLY | MPN: 940-99-00018 | |
| | | DPN: | |
| ADO 5.1 | CO2-POU-EN-MUR | MPN: 919-01-10002 | OR |
| | | DPN: | |
| ADO 5.2 | CO2-POU-LYR-EN-MUR | MPN: 919-01-10003 | OR |
| | | DPN: | |
| ADO 5.3 | CO2-POU-EN-NRO | MPN: 919-01-20002 | |
| | | DPN: | |
| ADO 6 | AMMONIA-POU-MUN | MPN: 929-01-00002 | |
| | | DPN: | |
| ADO 7 | LIGHT SENSOR-RLS-1-POU | MPN: 928-01-00001 | |
| | | DPN: | |

10.3.6 CARDS

- Door Cards
- Main Container Cards

10.3.6.1 Door Cards

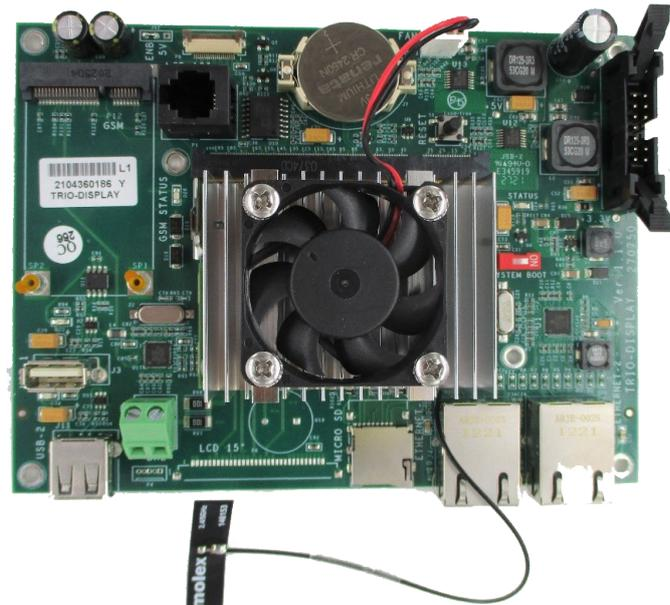
| Card | Description | Munters Ordering Number |
|---|---|-------------------------|
|  | <p>250061: LCD TFT 10.1' VT101C-KC17-B07A Vitek</p> <p>Or AM- 102460002TMQW-TA0H Ampire</p> <p>Or TWS2101RBTV20C APEX</p> | <p>940-99-00002</p> |
|  | <p>140672: USB CABLE FOR Vitek\Ampire DISPLAY</p> | <p>940-99-00027</p> |
|  | <p>Trio 20 -POU- DISPLAY CARD AND SOM VARISCITE CARD WITH HEATSINK AND FAN</p> | <p>940-99-00034</p> |

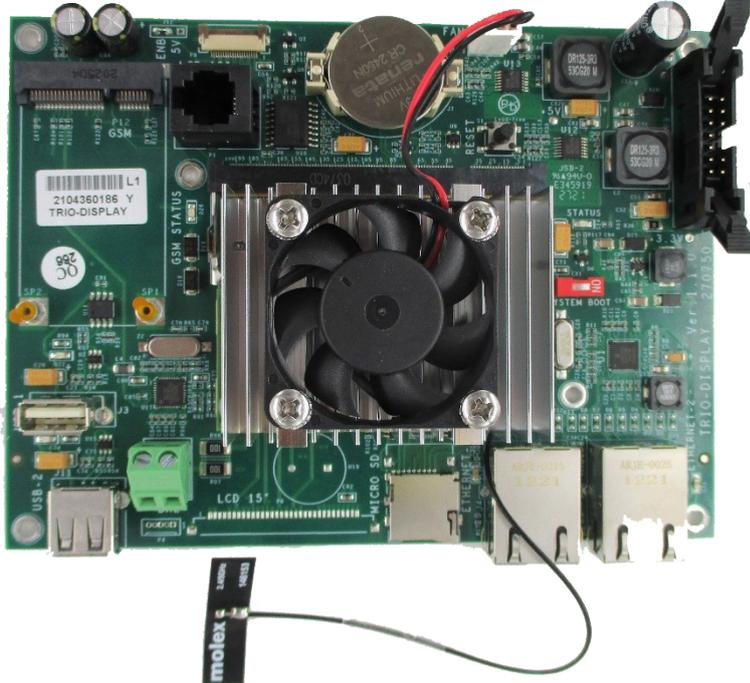
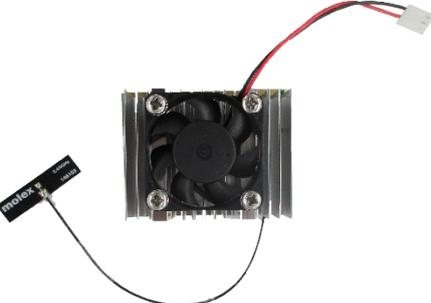
| Card | Description | Munters Ordering Number |
|---|--|--------------------------|
|  | <p>Trio 20 -POU-CN- DISPLAY CARD AND SOM VARISCITE CARD WITH HEATSINK AND FAN</p> <p><u>Note: China Only</u></p> | <p>940-99- 00032</p> |
|  | <p>R-Trio-DISPLAY: MUNTERS ROTEM MIDDLE RANGE 2 PC</p> | <p>940-99- 00004</p> |
|  | <p>Trio 20 -POU- SOM VARISCITE CARD WITH HEATSINK AND FAN</p> | <p>940-99- 00008</p> |

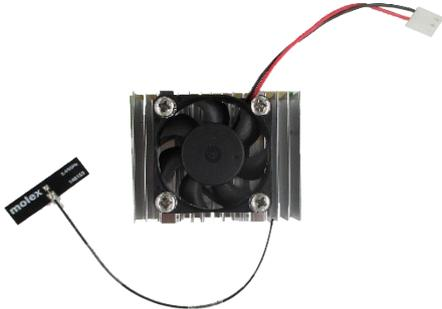
| Card | Description | Munters Ordering Number |
|---|--|-------------------------|
|  | <p>Trio 20 -POU-CN-SOM VARISCITE CARD WITH HEATSINK AND FAN</p> <p><u>Note: China Only</u></p> | <p>940-99-00044</p> |
|  | <p>Trio 20 HEATSINK AND FAN FOR SOM CARD</p> | <p>940-99-00026</p> |
|  | <p>204152: FAN FOR SOM CARD HEATSINK</p> | <p>940-99-00025</p> |
|  | <p>491009: ANTENNA WI-FI MOLEX 1461530150 15cm CABLE, U.FL/I-PEX MHF</p> | <p>940-99-00035</p> |

10.3.6.2 Main Container Cards

| Card | Description | Munters Ordering Number |
|---|---|-------------------------|
|  | <p>R-Trio-20-MAIN: MUNTERS ROTEM MIDDLE RANGE 2 CPU</p> | <p>940-99-00003</p> |
|  | <p>370193: SWPS LPV-60-12 Mean Well 100-240V 12V 60W</p> | <p>900-99-00264</p> |
|  |  <p>STATIC PRESSURE SET - AC3G/SE/PL/Trio -POU</p> | <p>901-99-00025</p> |

| Card | Description | Munters Ordering Number |
|--|--|-------------------------|
|  | TUBES AND FILTERS FOR RPS (NO RPS CARD) | 999-99-00503 |
|  | R-Trio-RSC-2: Trio 20 SCALE CARD 2CH | 940-99-00013 |
|  | R-Trio-RSC-6: Trio 20 SCALE CARD 6CH | 940-99-00014 |

11Appendix C: Trio Expansion 10

- Expansion Layout
- Expansion Wiring Diagrams
- Trio / Trio Expansion Termination
- Key
- Product Symbols
- Mapping Devices in Expansion
- Expansion Specifications
- Expansion Spare Parts

11.1 Expansion Layout

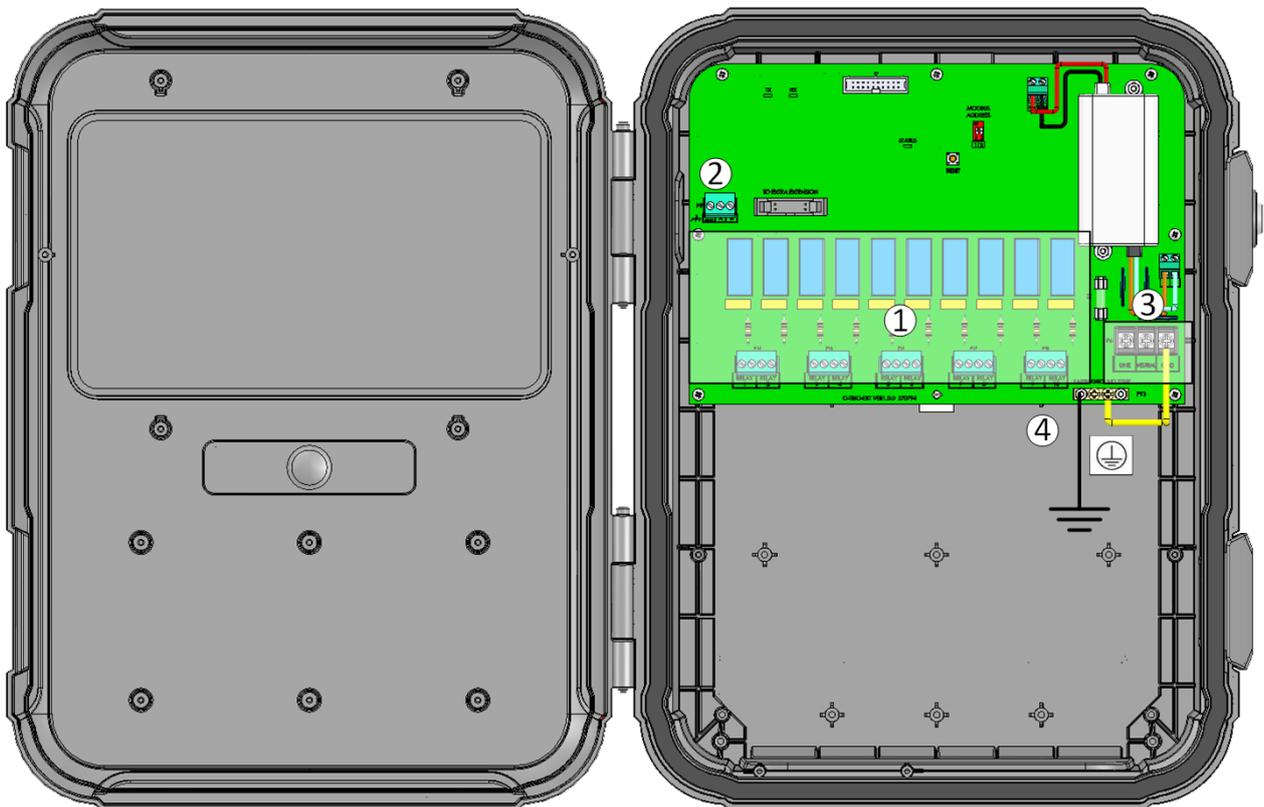

Figure 35: Board layout

| | |
|---|--------------|
| 1 | 10 relays |
| 2 | RS-485 ports |
| 3 | Power ports |
| 4 | Ground strip |

11.2 Expansion Wiring Diagrams

- Trio to Trio Expansion Wiring
- High Voltage Relays
- Alarms and Power

11.2.1 TRIO TO TRIO EXPANSION WIRING

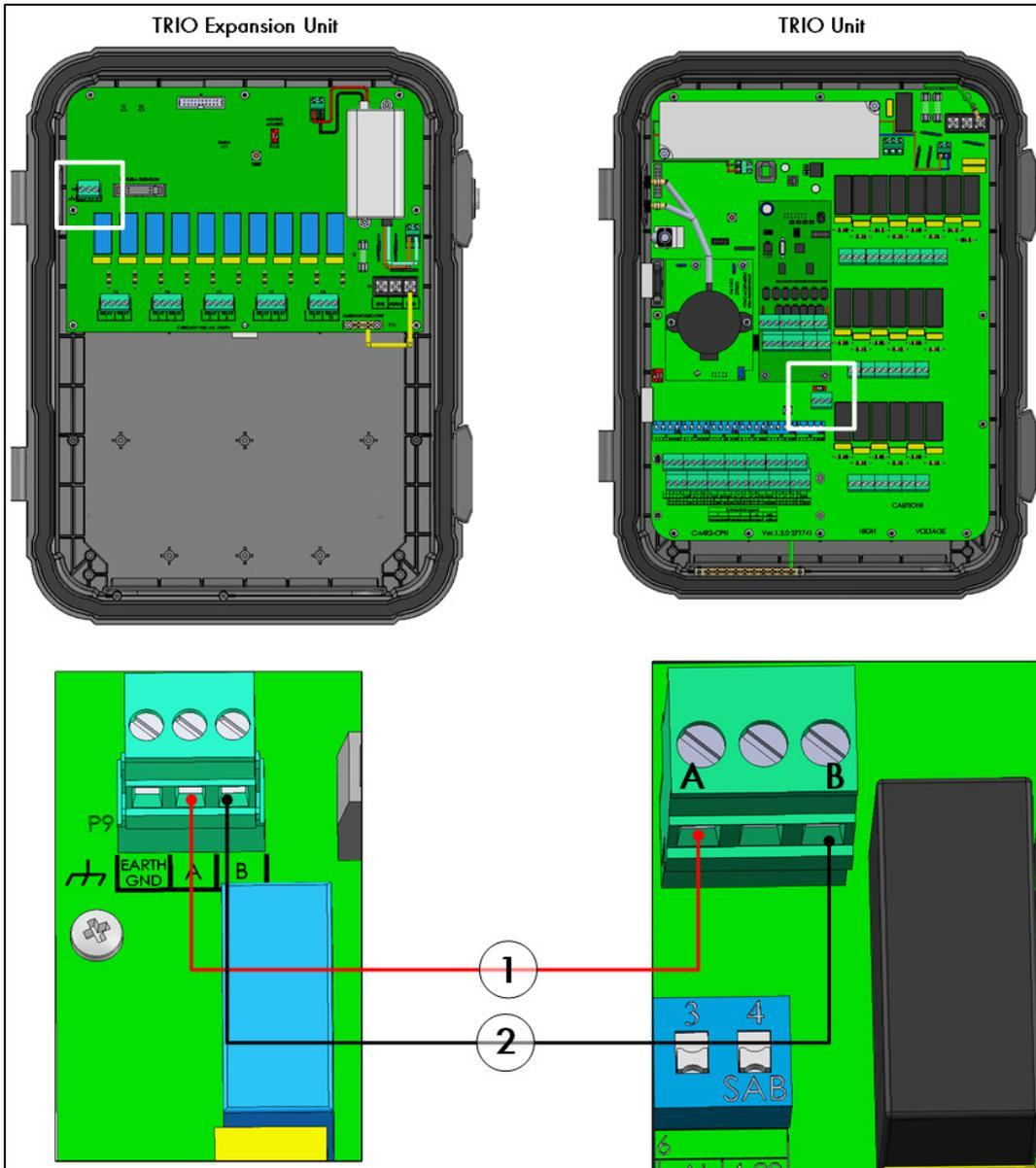

Figure 36: Wiring diagram

- The cable between the controller and the expansion unit should be a 4-wire twisted shielded cable (22 or 24 AWG).
- 1 – red wire
- 2 – black wire

11.2.2 HIGH VOLTAGE RELAYS

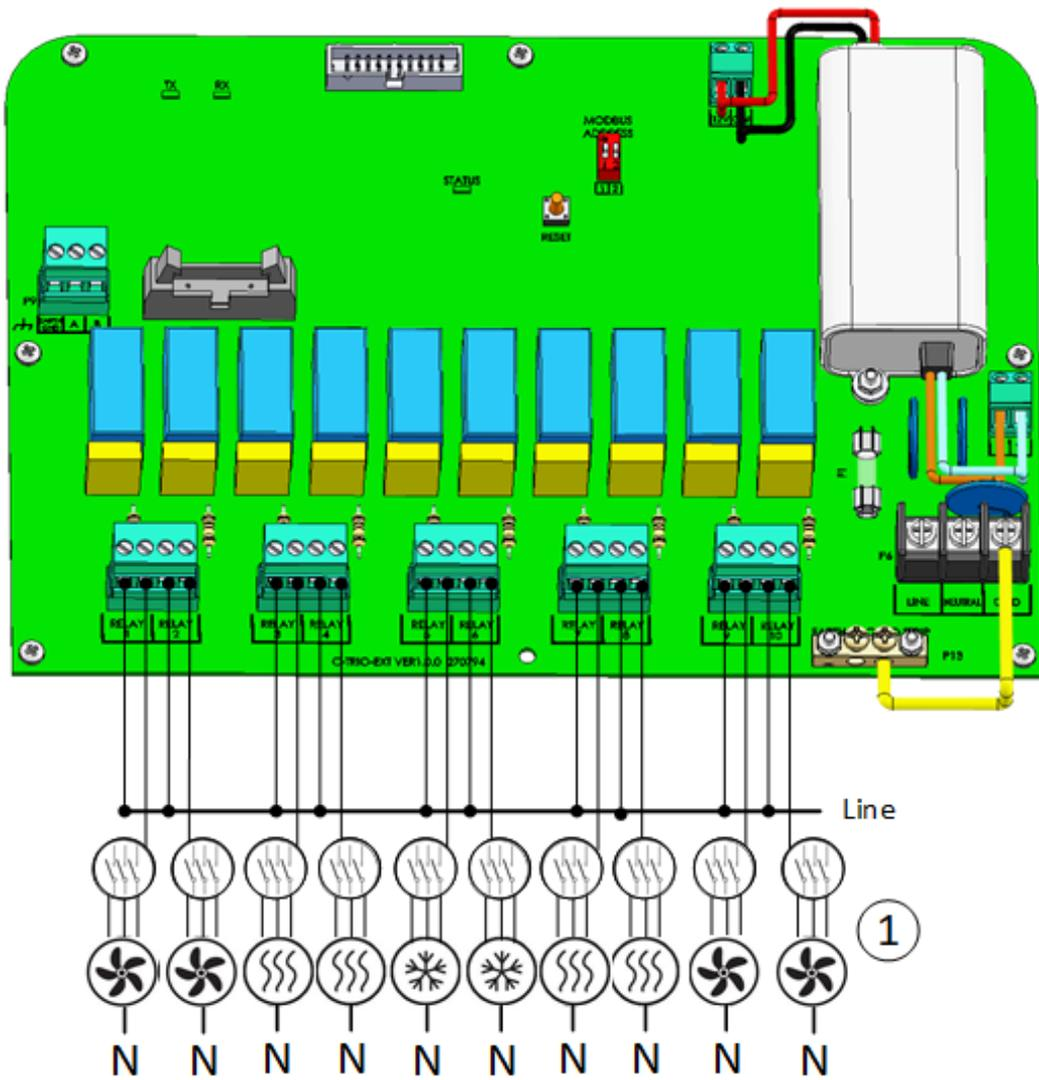

Figure 37: High voltage devices (examples)

| | |
|---|--------------------|
| 1 | Example of devices |
|---|--------------------|

NOTE The relays control motors and heating devices via contactors, not directly.

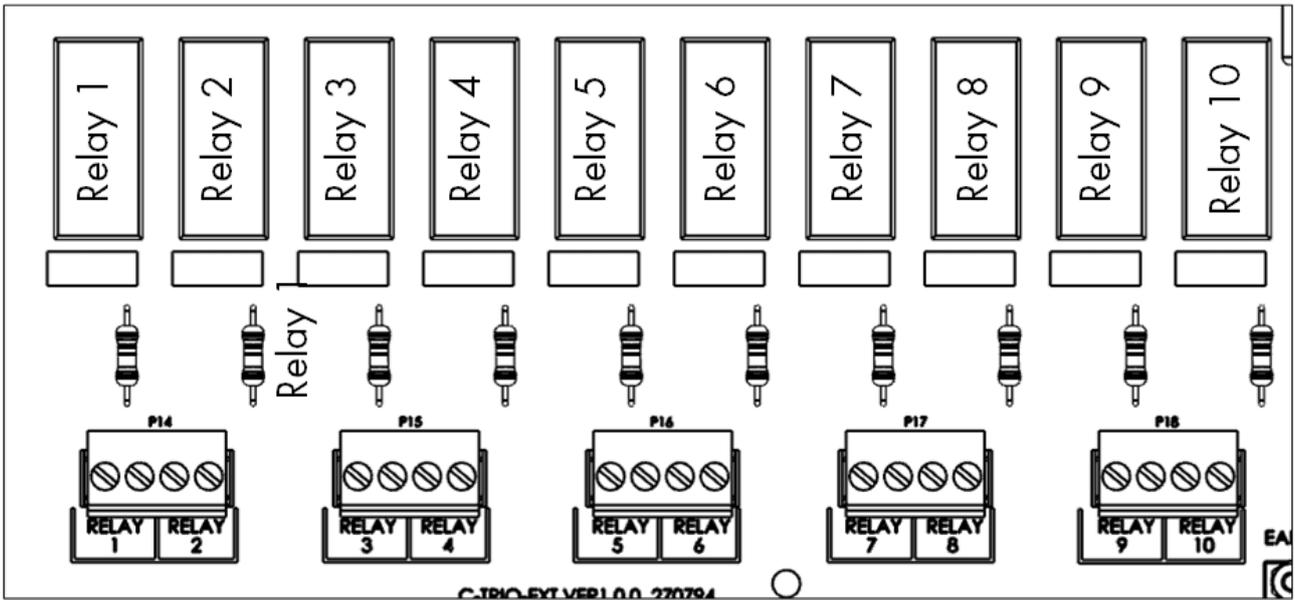

Figure 38: Relay and port numbering

11.2.3 POWER

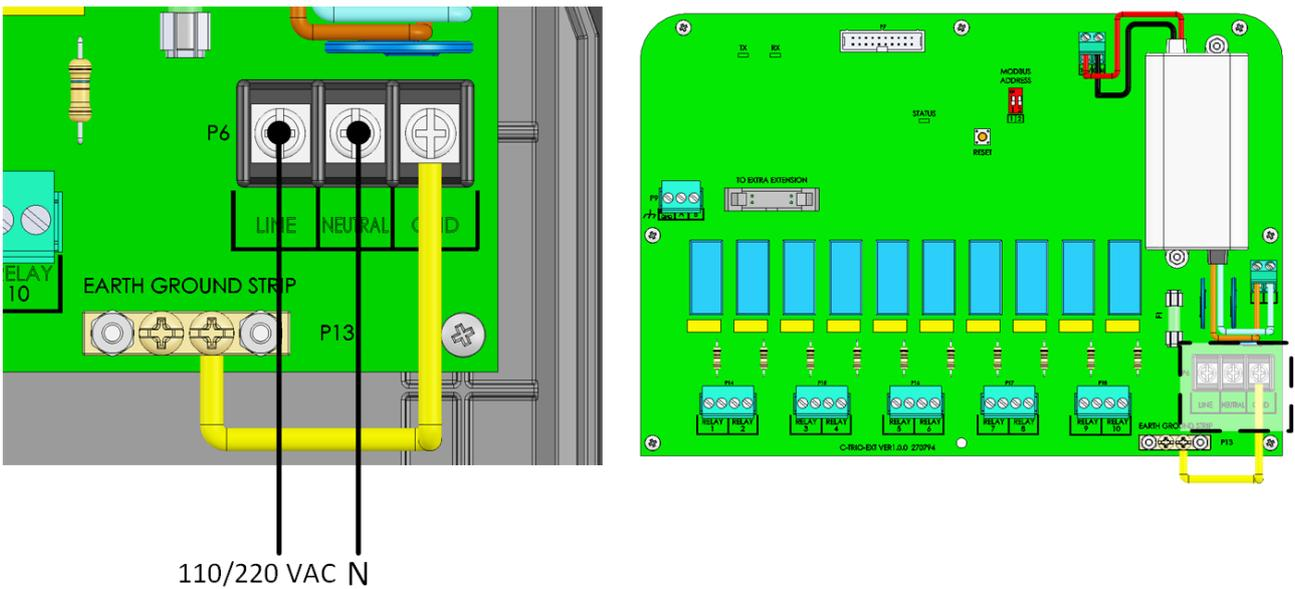
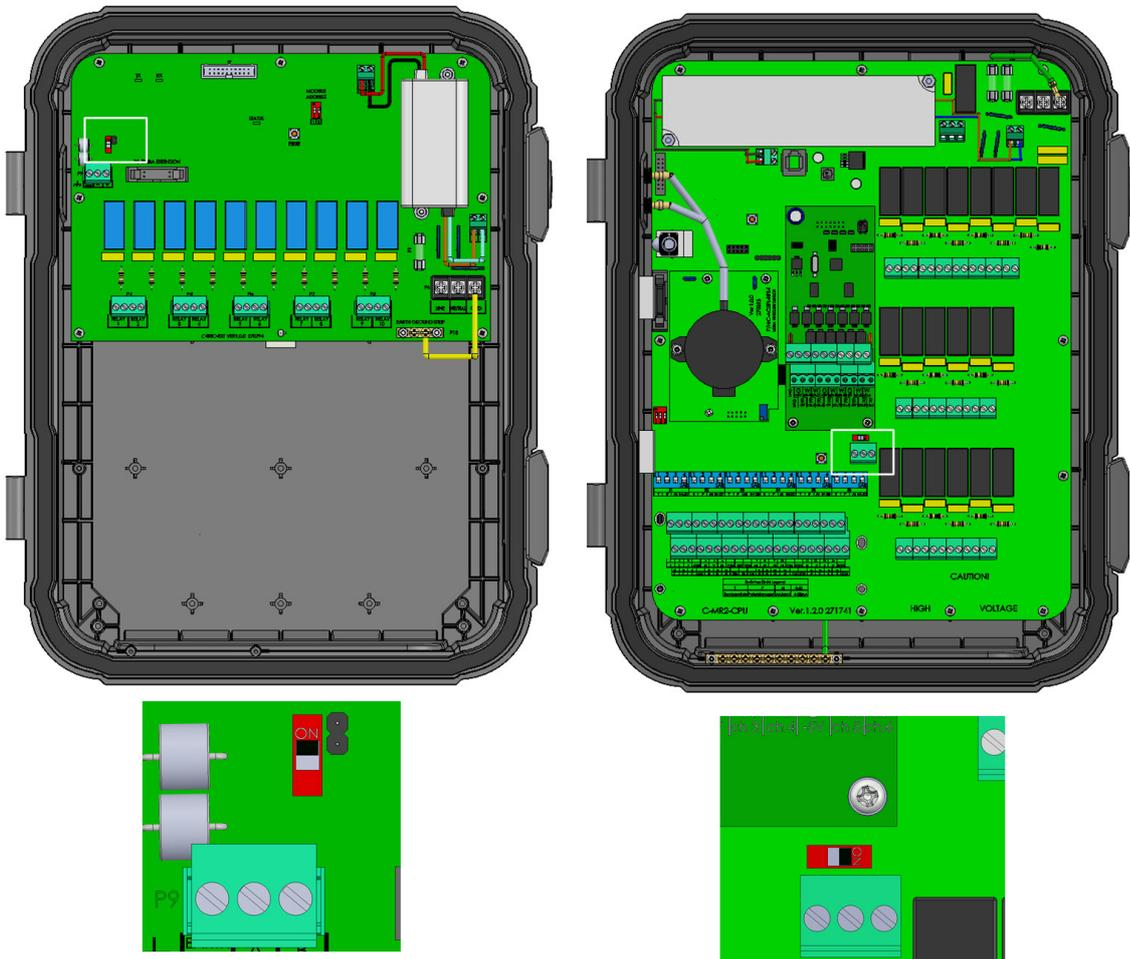

Figure 39: Power ports

11.3 Trio / Trio Expansion Termination

When Trio is wired to a Trio Expansion unit, the termination dipswitch in both units must be set to ON.



NOTE When the Trio is not wired to an Expansion device, the termination dipswitch position is irrelevant.

11.4 Key

Ensure that the unit remains locked to prevent unauthorized access to internal components.

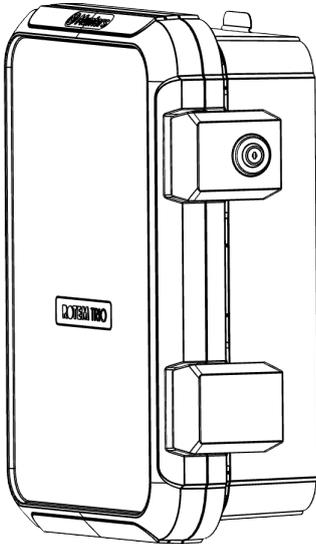

Figure 40: Expansion Unit Lock

11.5 Product Symbols

The following labels appear on your controller:



: Caution! Hazardous voltage



: Caution: Refer to the manual



: Main Protective Earthing Terminal

CAUTION IF THE UNIT IS USED IN A MANNER NOT SPECIFIED BY THE MANUFACTURER, THE PROTECTION PROVIDED BY THE EQUIPMENT MAY BE IMPAIRED.

11.6 Mapping Devices in Expansion

- Install and wire the Expansion unit to the Trio and to the external devices before beginning.

- After wiring the Expansion unit to Trio, go to System > General Settings > Info 

Reset Factory Settings 

and click . Follow the online instructions. Trio will not recognize the Expansion until this step is performed.

After wiring devices to the Trio Expansion Unit, each device must be mapped and then defined. Mapping and defining devices enable the system software to control each device's functionality.

CAUTION Mapping *MUST* match the physical wiring! An error message appears if the physical device is not wired to the relay or port as defined on the mapping screen..

To map the devices:

1. Go to System > Device and Sensors.

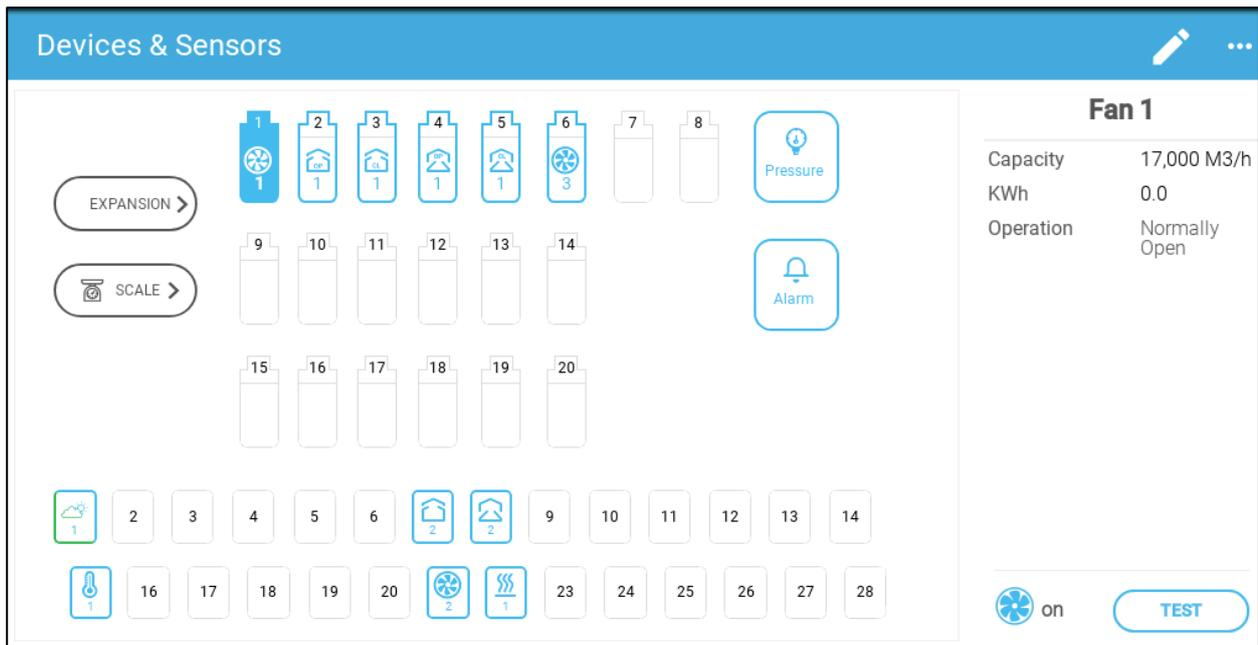

The screenshot shows the 'Devices & Sensors' configuration screen. It features a grid of 28 numbered slots. The first two rows (slots 1-14) are grouped under 'EXPANSION' and 'SCALE' buttons. Slots 1-8 are under 'EXPANSION' and slots 9-14 are under 'SCALE'. Slots 1-14 contain various icons: slot 1 has a fan icon, slots 2-5 have house icons, slot 6 has a pressure icon, slot 7 has a fan icon, slot 8 is empty, slot 9 has a house icon, slot 10 has a house icon, slot 11 is empty, slot 12 is empty, slot 13 is empty, slot 14 is empty. Slots 15-28 are empty. On the right, the 'Fan 1' panel displays: Capacity: 17,000 M3/h, KWh: 0.0, Operation: Normally Open, and a 'TEST' button.

2. Click Expansion.

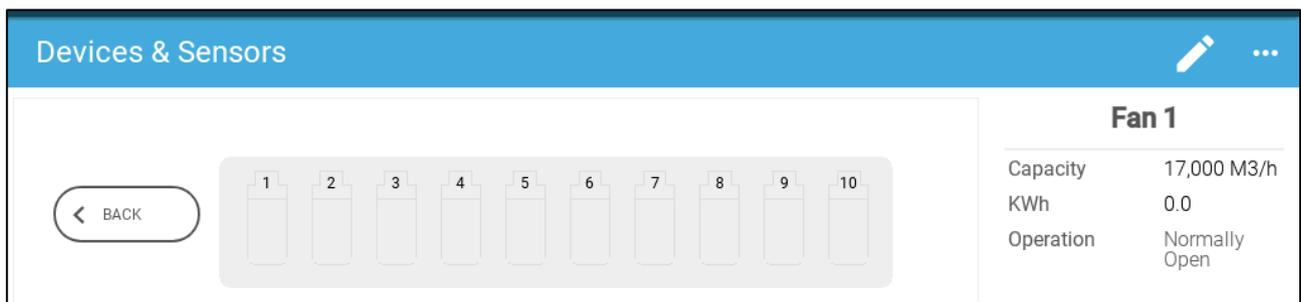

The screenshot shows the 'Devices & Sensors' configuration screen after clicking 'Expansion'. The grid now only shows 10 numbered slots (1-10) under the 'EXPANSION' group. A 'BACK' button is visible on the left. The 'Fan 1' panel on the right shows: Capacity: 17,000 M3/h, KWh: 0.0, Operation: Normally Open.

3. Map the devices as detailed in the Trio manual. Refer to Mapping Devices, page 48 for more information.

11.7 Expansion Specifications

| Parameter | Specifications |
|---|--|
| Input Power Voltage | 115/230 VAC, 50/60 Hz |
| Input AC Power | 0.2A |
| Maximum number of relays operating simultaneously | 10 |
| <i>Note: Running relays at the above current levels provides between 50,000 – 100,000 switching operations.</i> | |
| Communication | RS-485: 115 Kbps, 8 bits, even parity |
| Operating Temperature Range | -10° to +50° C (+14° to +125° F) |
| Storage Temperature Range | -20° to +80° C (-4° to +176° F) |
| Environmental Specifications | <ul style="list-style-type: none"> • Altitude: -400 m to 2000 m • Relative Humidity: 20% - 90% • Main supply voltage fluctuation up to +10 - 20% • Overvoltage category II |
| Enclosure | <ul style="list-style-type: none"> • Water and dust tight • Indoor use only |
| Dimensions (H/W/D) | 403 x 324 x 141 mm/16 x 13 x 5.6 inches |
| Fuses | Fuse F2 on PS card: 3.15A, 250V |
| Certification |     |

- **Disconnection device/overcurrent protection:** In the building installation, use a certified 2-pole circuit breaker rated 10A, certified in accordance with the IEC standard 60947-2 (in the US and Canada use a Listed Branch Circuit protective circuit breaker). This step is required to provide overcurrent protection and mains disconnection. The circuit breaker must be easily accessible and marked as the controller disconnect device.
- **Main Supply Voltage:** Permanently connect the controller to the mains in accordance with the relevant national code. Provide fixed wiring inside a flexible conduit. Relays must be suitably protected against overcurrent, using a circuit breaker rated at 10A.

11.8 Expansion Spare Parts

- Preliminary Information
- Trio 20 Container Spare Parts
- Trio 20 Main Container Spare Parts
- Main Container Card Spare Parts

11.8.1 PRELIMINARY INFORMATION

| | |
|----------------------|---------------------|
| | Trio 10 EXP |
| Container | A |
| Main Container Cards | B |
| MPN | Munters Part Number |
| DPN | Dealer Part Number |

11.8.2 TRIO 10 EXPANSION CONTAINER SPARE PARTS



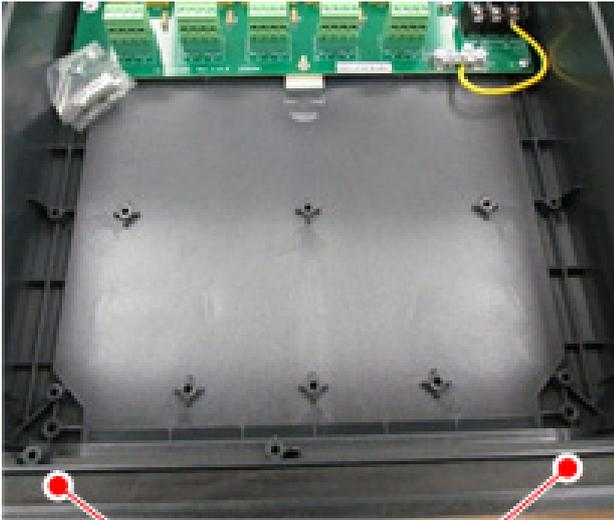

A4

| ID No. | Description | Order Catalog Number |
|-------------|--|---------------------------|
| A1.1 | Trio FRONT DOOR EXP PLASTIC PART V1.0.0 (SP: 207129) | MPN: 940-99-00028 DPN: |
| A1.2 | Trio-20 PLASTIC BOX BASE | MPN: 940-99-00007 DPN: |
| A1.3 | Trio HINGE PLASTIC PIN V1.0.0 (SP-207128) | MPN: 940-99-00019 DPN: |
| A2.1 | Trio-20 PANEL PLASTIC PART BLUE LOGO MUNTERS + PART BLUE | MPN: 940-99-00001 DPN: |
| A2.2 | Trio PANEL PLASTIC PART RED RAL 3020 NO LOGO (SP-207138) | MPN: 940-99-00045 DPN: |
| A3.1 | GENERAL PLASTIC LATCH | MPN: 900-99-00216 DPN: |
| A3.2 | ONE/ONE PRO LATCH GENERAL LOCK PLASTIC PART + LOCK FOR LATCH | MPN: 900-99-00217 DPN: |
| A4 | MID-RANGE MAIN GASKET V1.0.0 (SP-207122) | MPN: 940-99-00021 DPN: |

11.8.3 TRIO 10 EXPANSION MAIN CONTAINER SPARE PARTS

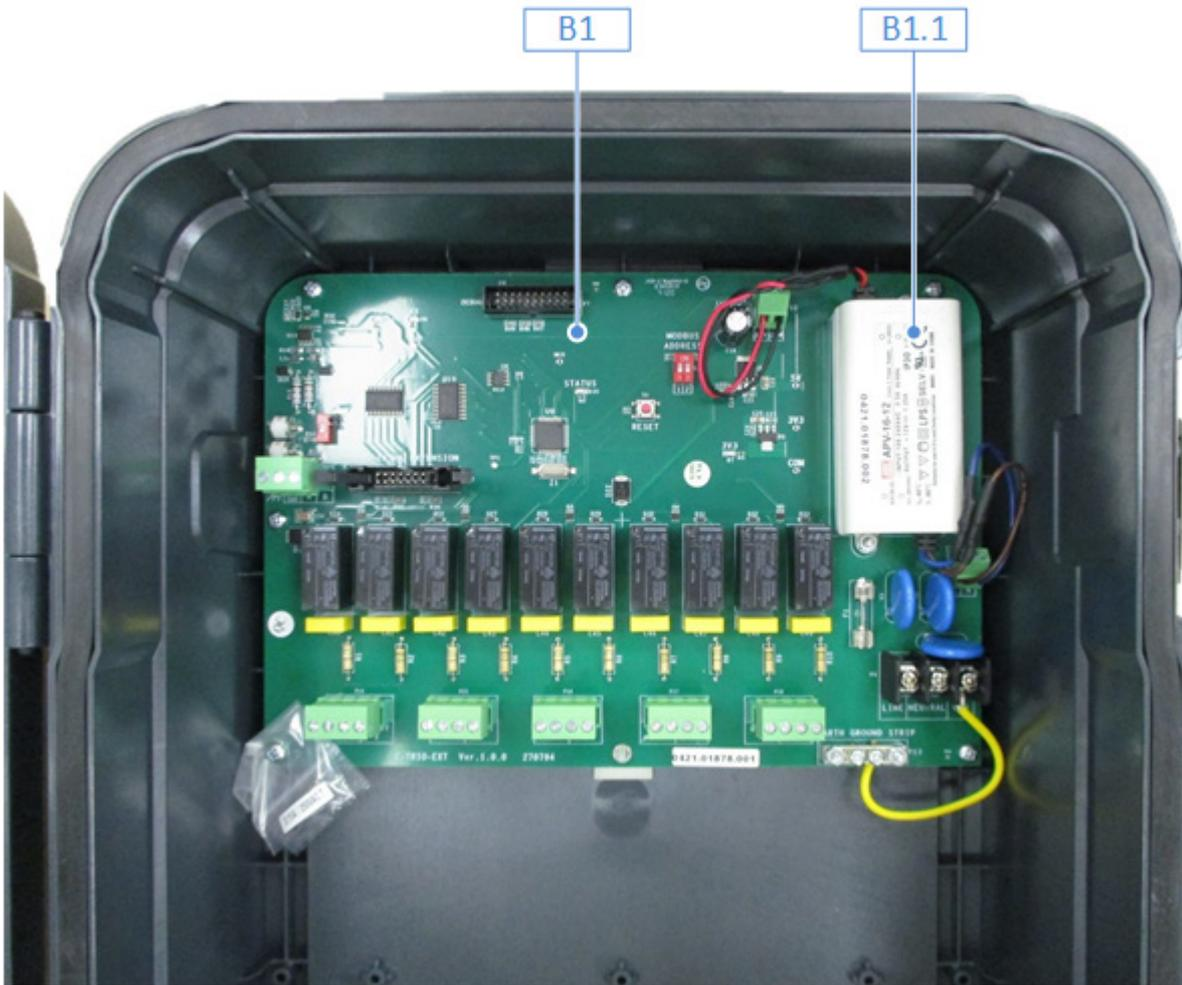

| ID No. | Description | Order Catalog Number |
|--------|---|----------------------|
| B1 | Trio-EXP 10 CARD (SP: R-Trio-EXP10) | MPN: 940-99-00029 |
| | | DPN: |
| B1.1 | SWPS APV-16-12 Mean Well 115V/230V 12V 16W (SP: 370153) | MPN: 999-99-00338 |
| | | DPN: |

12 Appendix D: Trio Cell Modem Installation

This document details how to install and configure a cell modem in a Trio unit lacking this device.

- Prerequisites
- Installation

12.1 Prerequisites

- Supported Devices
- Required Software
- Internet Access

12.1.1 SUPPORTED DEVICES

Trio Display Card Version 1.1.0 or above supports the modem.

- Order: 940-99-00049 Trio GLOBAL LTE CELL MODEM & EXTERNAL ANTENNA.
- For Trio Display Board versions 1.0 or lower, contact Customer Success.



Figure 41: SIM 940-99-00049 Front and Back

12.1.2 REQUIRED SOFTWARE

Trio cell modem requires the following software installations:

- Image Version 1.5. Consult with a Munters technician on how to install the image.
- Software Version 5.0 or higher. Upgrade this software via the Trio Software Upgrade screen.

12.1.3 INTERNET ACCESS

Trio has a priority system for internet access:

1. LAN connection
2. WIFI
3. Cell modem

If a LAN connection is available, Trio automatically connects to the web via the LAN only, even if the unit supports WIFI or a cell modem connection. If there is no LAN, Trio uses WIFI. Trio will only use the cell modem when the first two options are not available.

12.2 Installation

- Physical Installation
- Configuration

12.2.1 PHYSICAL INSTALLATION

- Modem and SIM Card
- Drilling

12.2.1.1 Modem and SIM Card

1. Locate the designated spot for the modem.

2. Insert the modem into the connector and secure it using the two screws supplied.

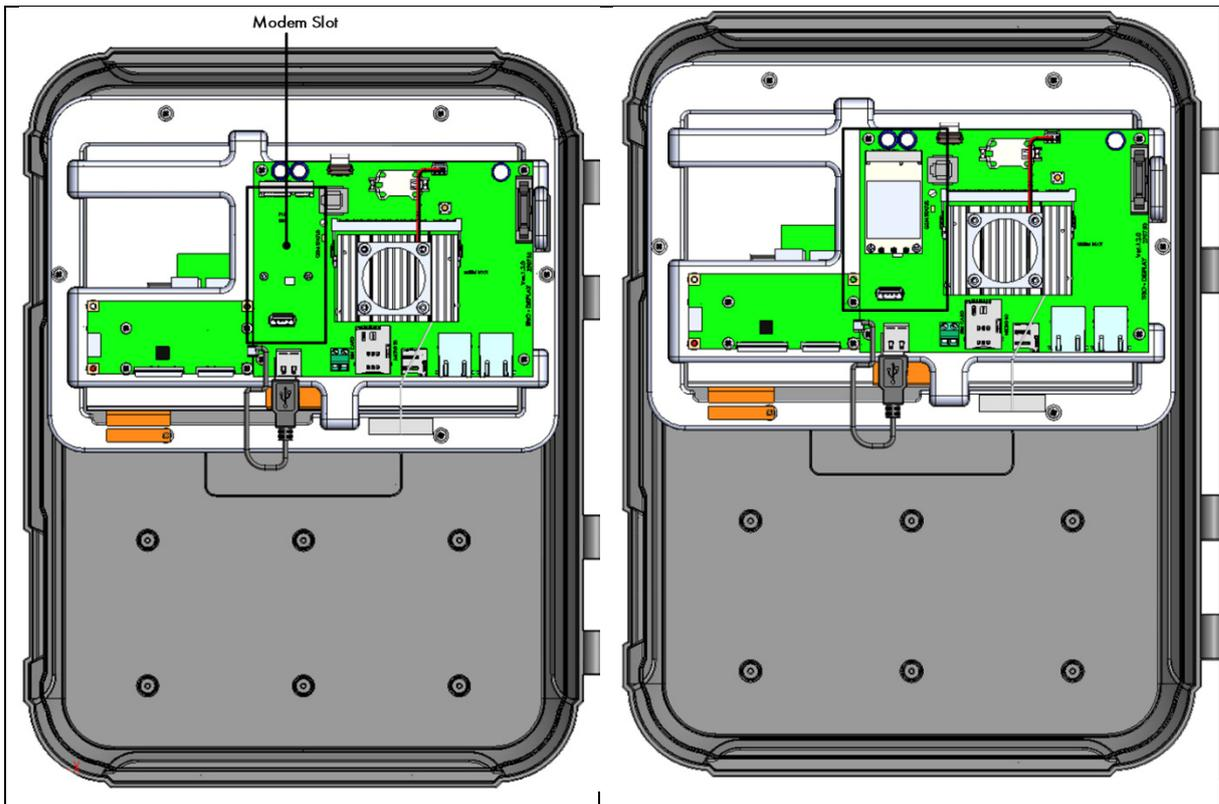

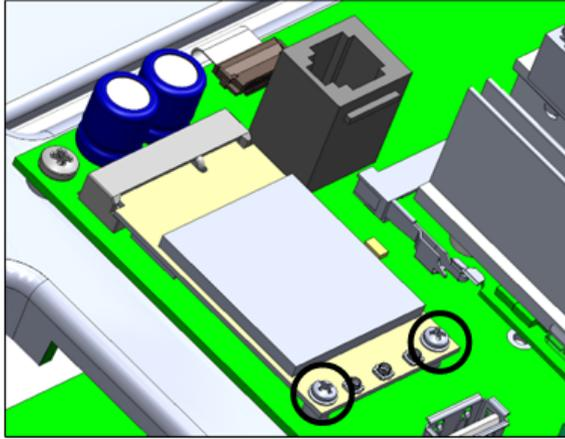

3. Insert the SIM card into the SIM port.

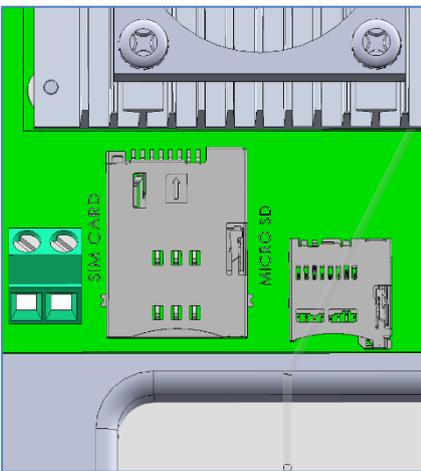

4. Gently press the cable connector onto the modem.

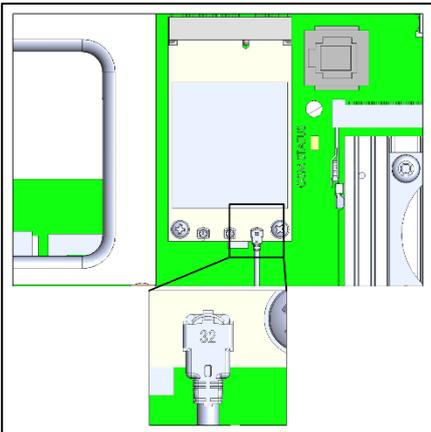

5. Thread the modem cable to the connector as shown below.

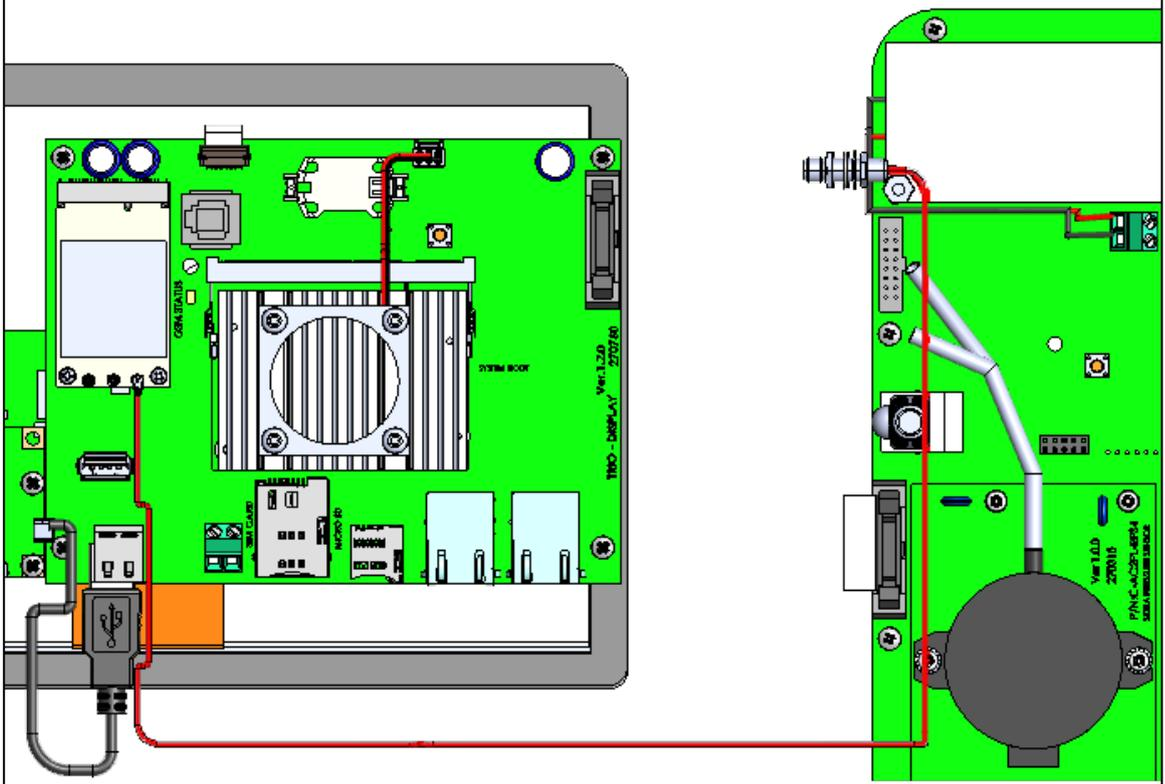
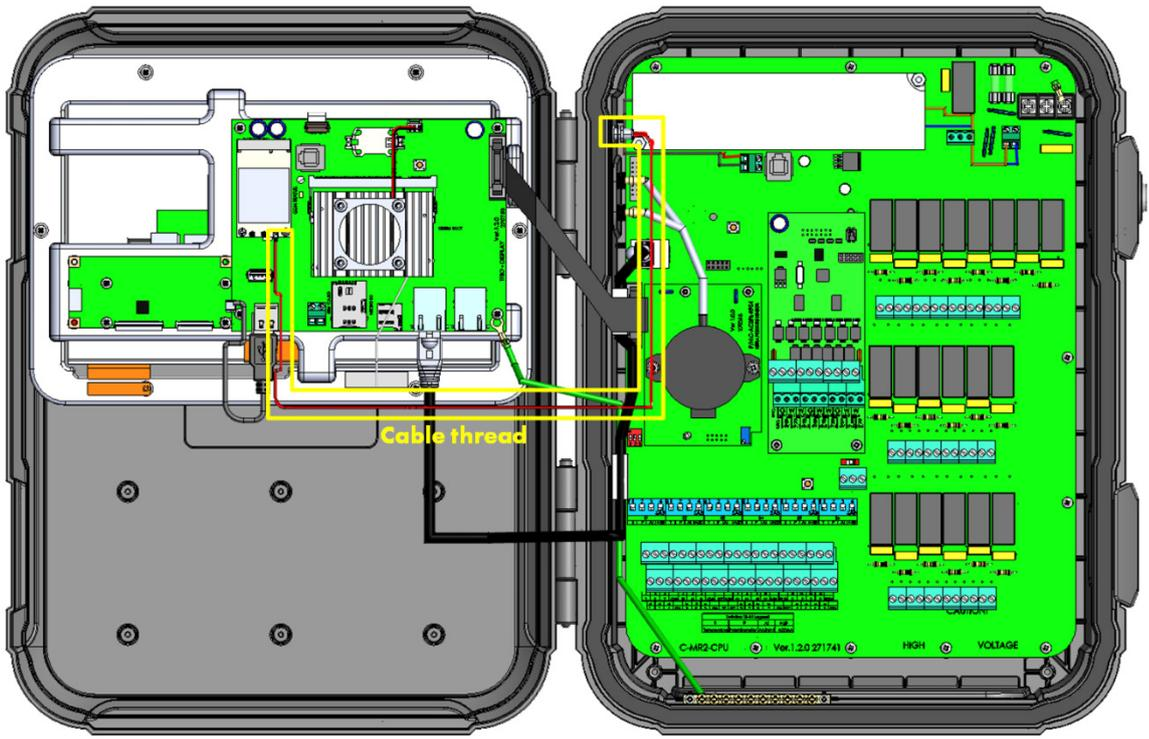

6. Remove the plug in the spot designated for the SMA connector.

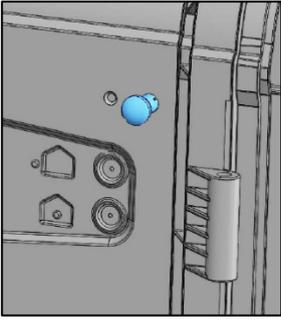

7. Remove the sealing cap and attach the antenna. (For older units, refer to the next section.)

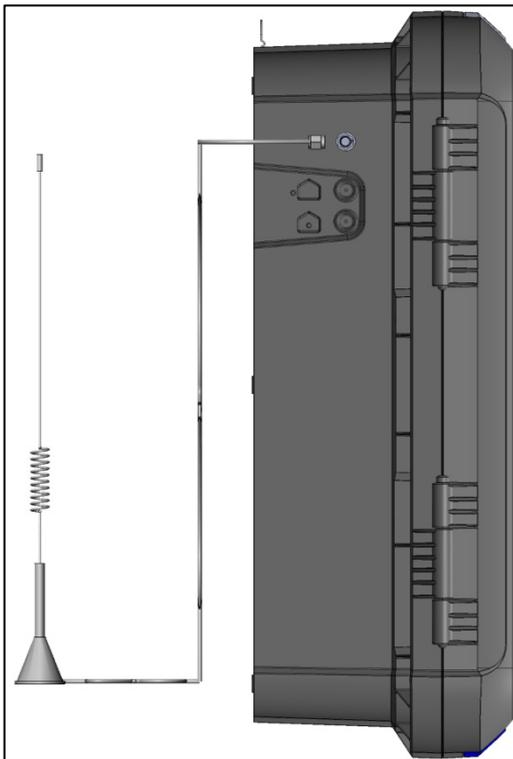

8. Secure the antenna using the brace provided.

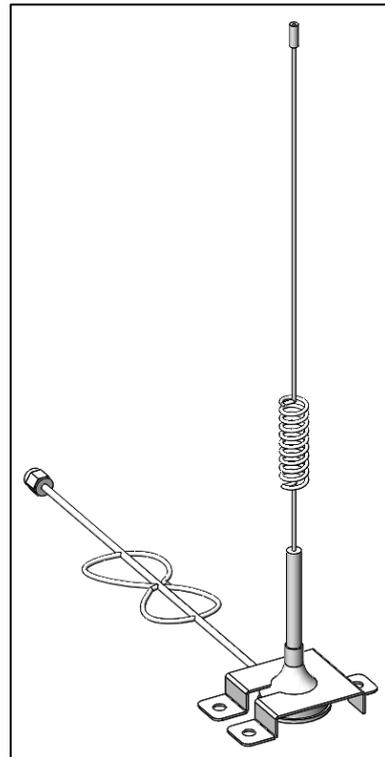

12.2.1.2 Drilling

In the event that the Trio unit was shipped before 08/2022, a hole must be drilled for the SMA connector.

1. Drill a 6.5-millimeter hole in the spot shown below.

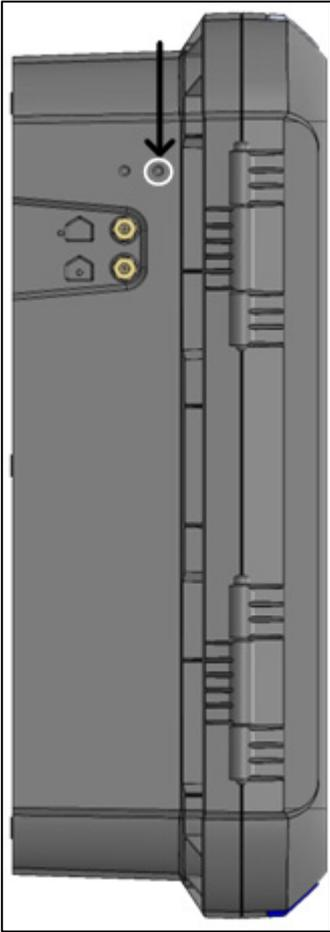

2. Insert and secure the SMA connector.

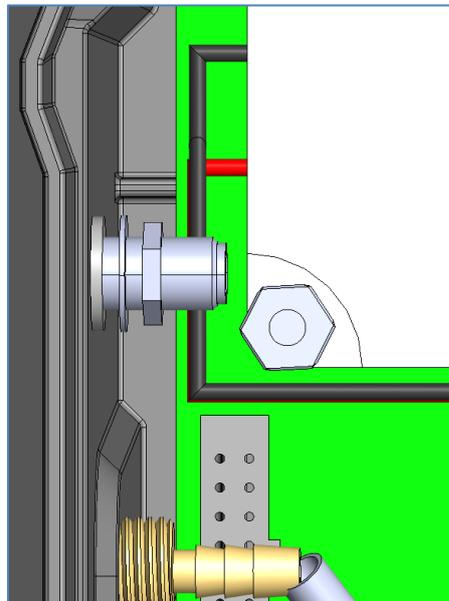
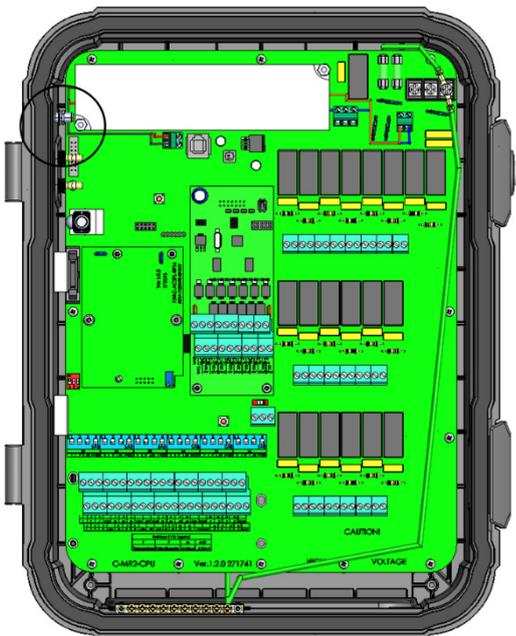

3. Thread the modem cable to the connector as shown below.

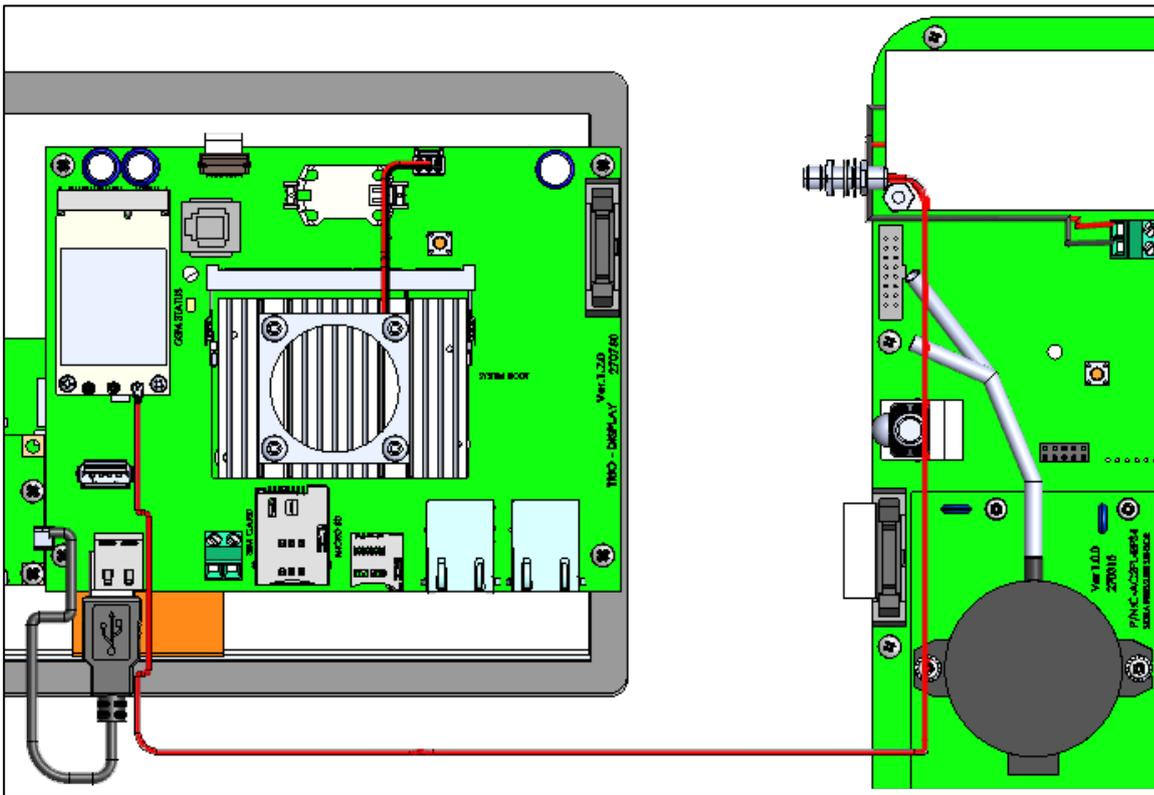
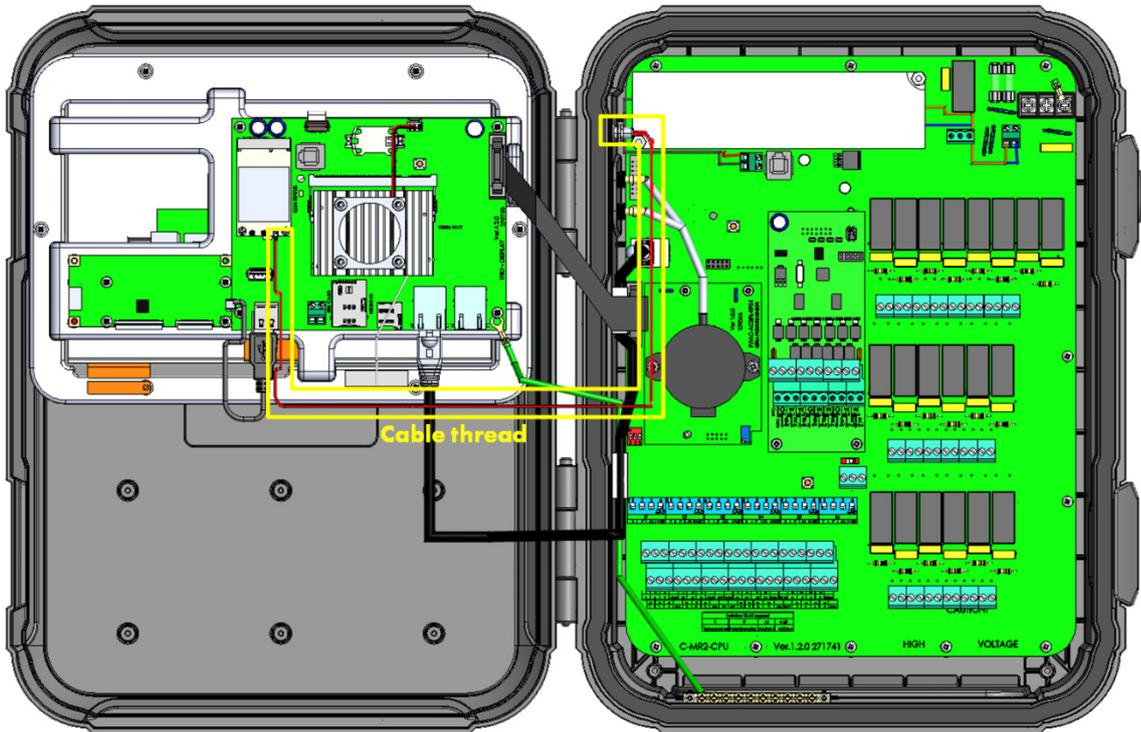

12.2.2 CONFIGURATION

NOTE The cellular Modem function appears only if a modem is installed with a working SIM card.

To configure the cell modem:

1. Go to System > General Settings > Network.

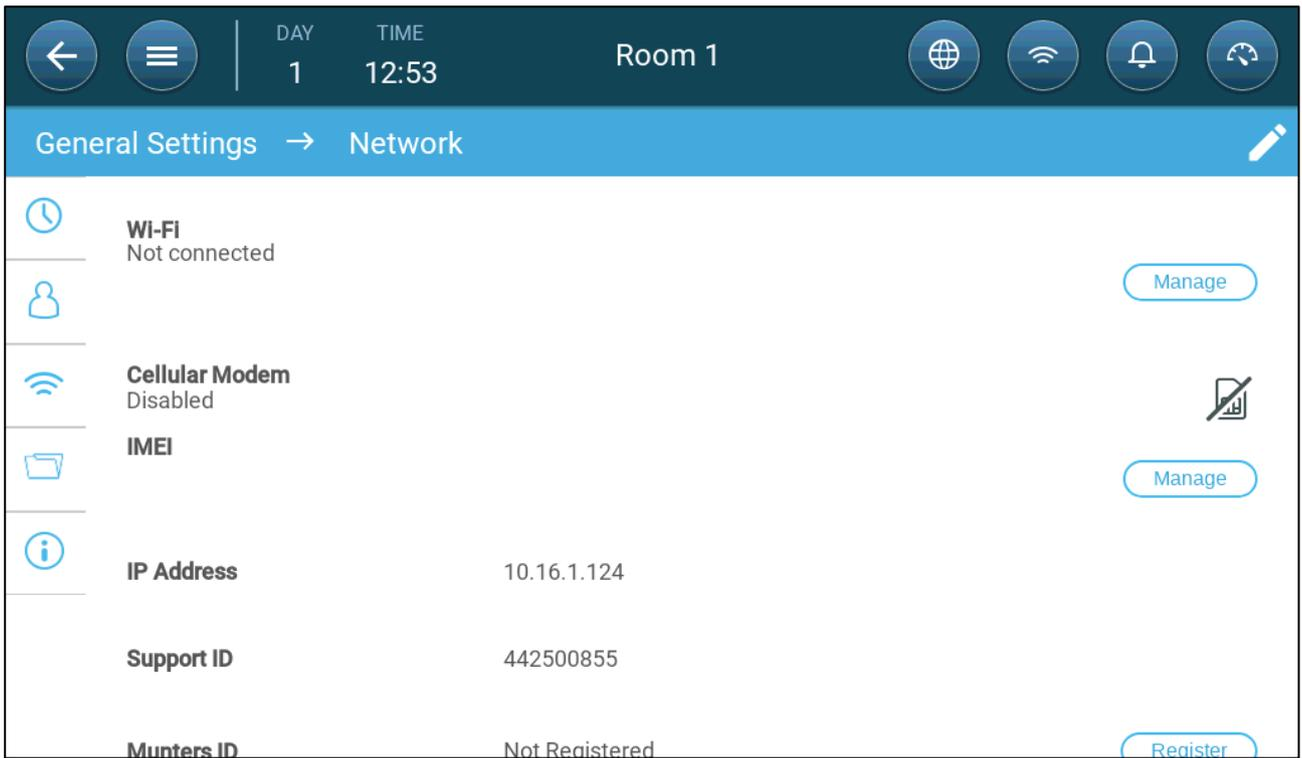

2. Under Cellular Modem, click **Manage**.

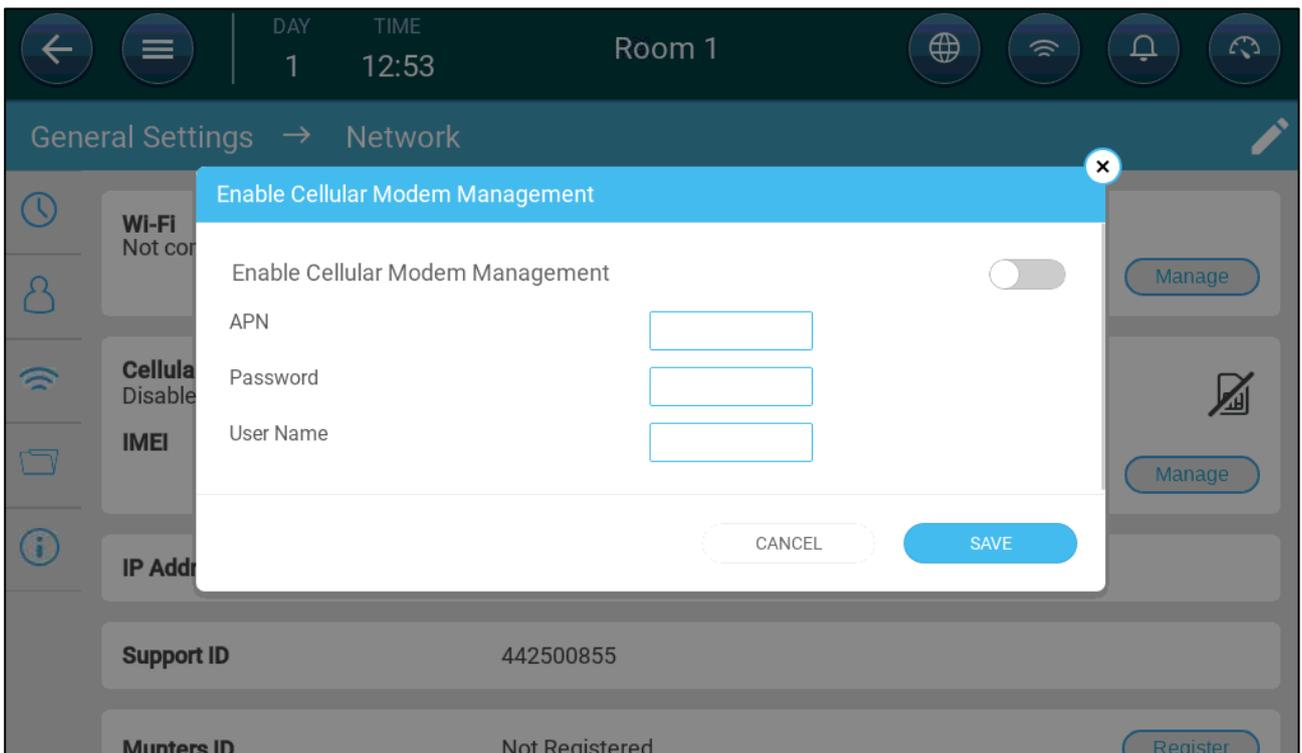

3. Under Cellular Modem, click **Manage**.

4. Final steps:

- a. Enable the modem.
- b. Using data provided by your service provider, enter the data in the fields.
- c. Click **Save**.

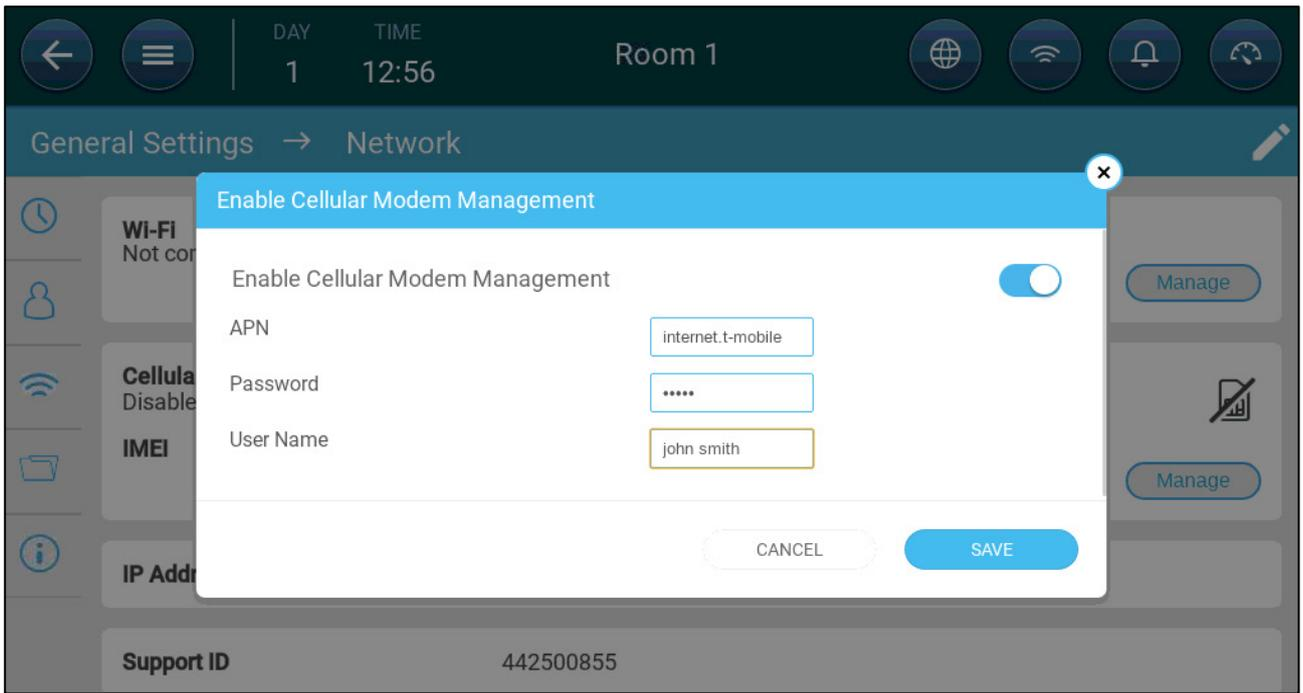

(example only!)

13 Appendix E: Panel Mount Installation

The following section details the Trio Panel Mount and Trio Expansion Panel Mount installation.

- Trio Panel Mount Installation
- Trio Expansion Panel Mount Installation

13.1 Trio Panel Mount Installation

The Trio Panel Mount consists of two elements, connected by flat ribbons and internet cable:

- Front panel (CPU panel)
- Rear panel (relay / card panel)

- Precautions
- Panels
- Panel Dimensions
- Mounting the Panels
- Panel Cables
- Powering and Alarms
- Grounding

13.1.1 PRECAUTIONS

Ensure the following:

- The setup meets electrical, mechanical and fire enclosure requirements.
- Clearance and creepage distances are maintained.
- Grounding meets industry standards.
- Ambient temperatures do not go above product requirements (50° C).
- If this unit is installed in an electrical closet, ensure that no contactors are in that closet. Placing this unit in proximity to contactors results in severe signal interference.

13.1.2 PANELS



Figure 42: Trio CPU Panel, Front View

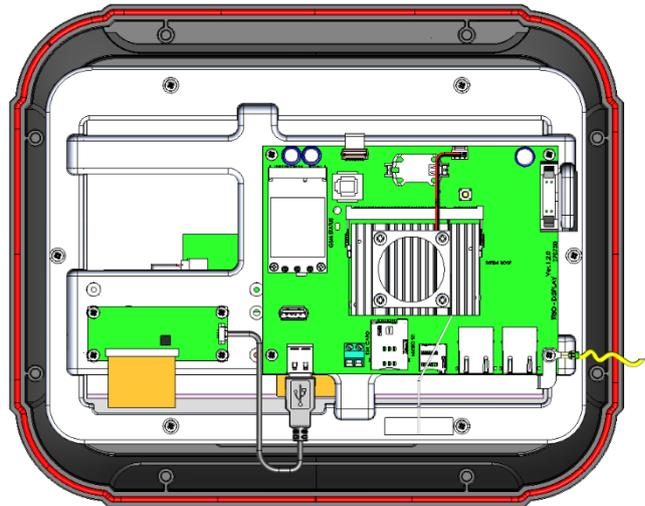

Figure 43: Trio CPU Panel, Rear View

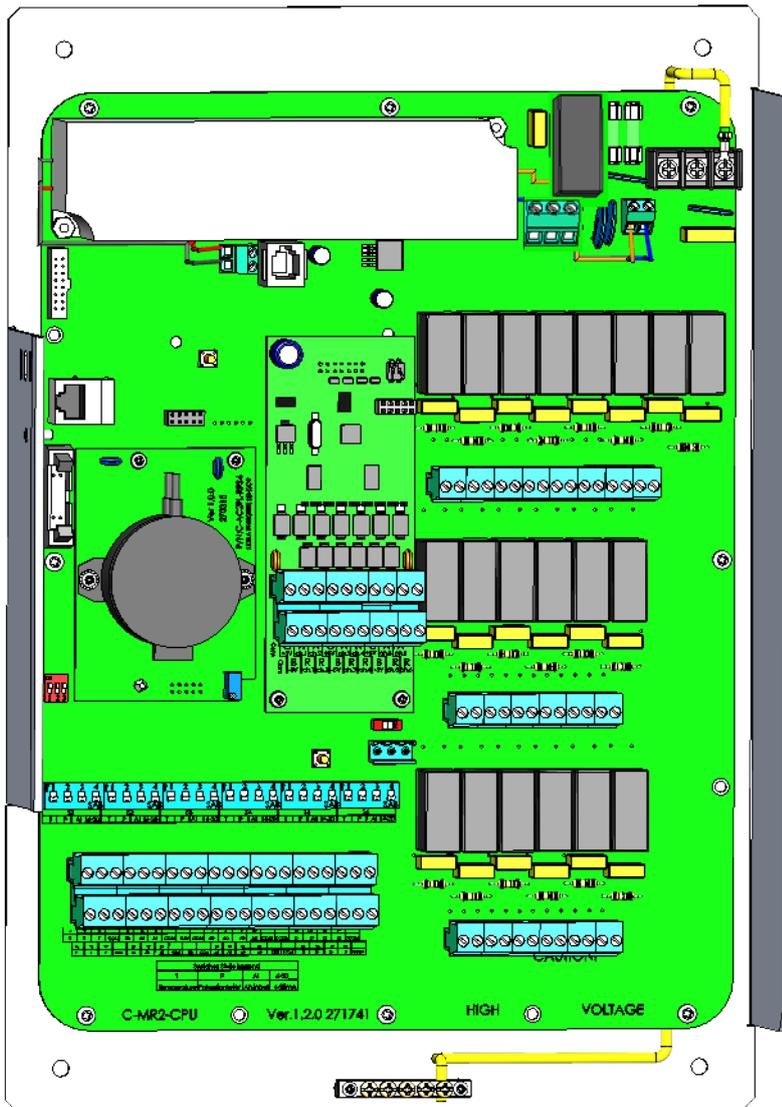

Figure 44: Trio Relay Panel, Front View

13.1.3 PANEL DIMENSIONS

Distances are in millimetres.

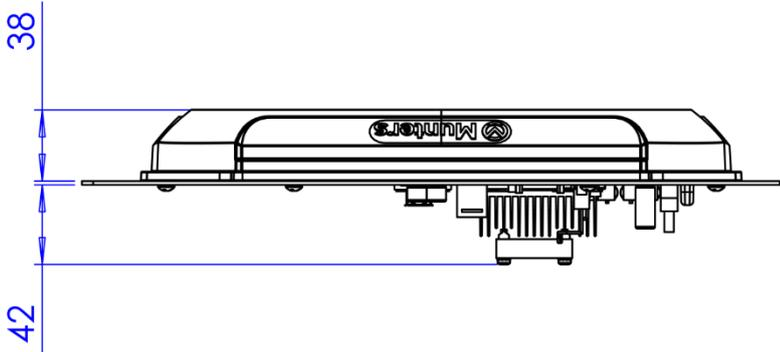

Figure 45: Front Panel Depth Dimensions

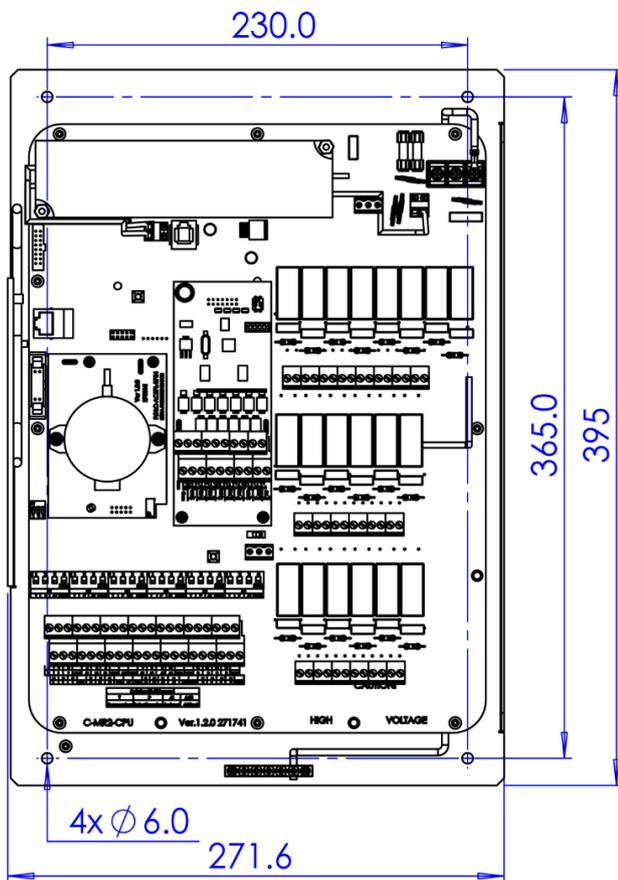

Figure 46: Rear Panel Dimensions

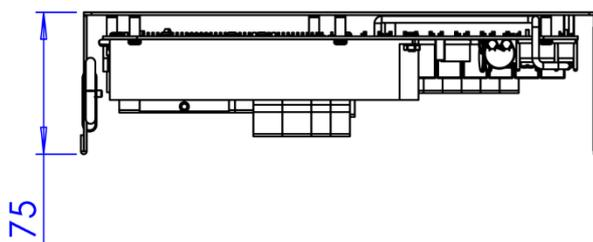

Figure 47: Rear Panel Depth Dimensions

13.1.4 MOUNTING THE PANELS

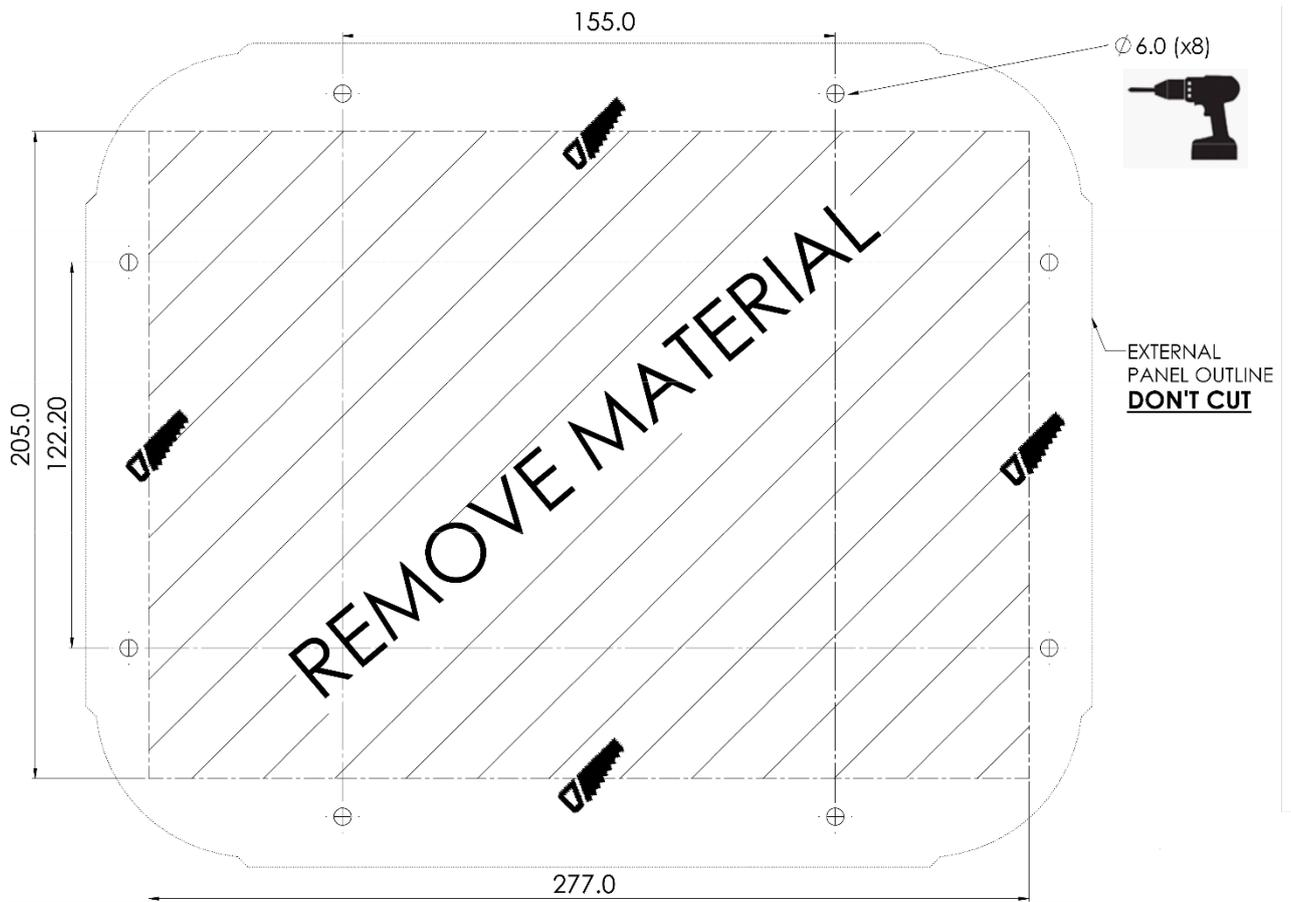

Figure 48: Panel Cutting and Drilling Dimensions (millimeters)

- Drill eight holes as indicated above.
- Using the dimensions shown, cut out a space into which the CPU Front Door is placed.

13.1.5 PANEL CABLES

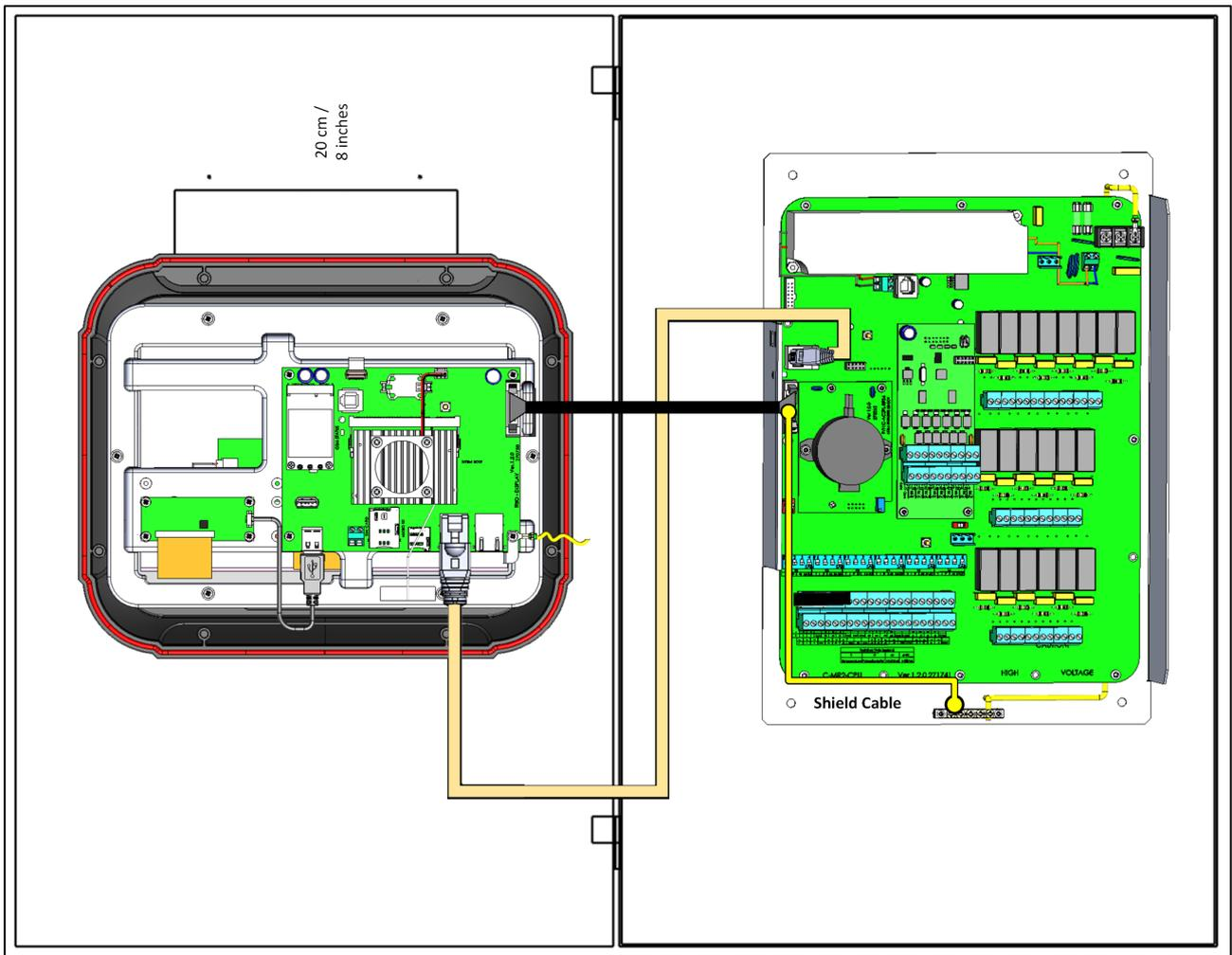

Figure 49: Panel Mount, Open Closet (sizes are not to scale)

- Connect the flat cable and internet cable as shown above.
- Mount the Trio Panel Front Door on the left door (hinge on left side).
- The distance between the Front Door and the Rear Panel must be less than one (1) meter!
- Make sure that there is at least 20 cm/8 inches between the Trio relay plate and any power contactors or other metal equipment.
- Any inverter must be at least five meters away from the controller.
- To prevent signal disruption, do not run sensor wiring via the DIN rails.
- Do not run power wires through the area of the Trio relay plate.

13.1.6 POWERING AND ALARMS

- Connect the light or siren device to the alarm relay.

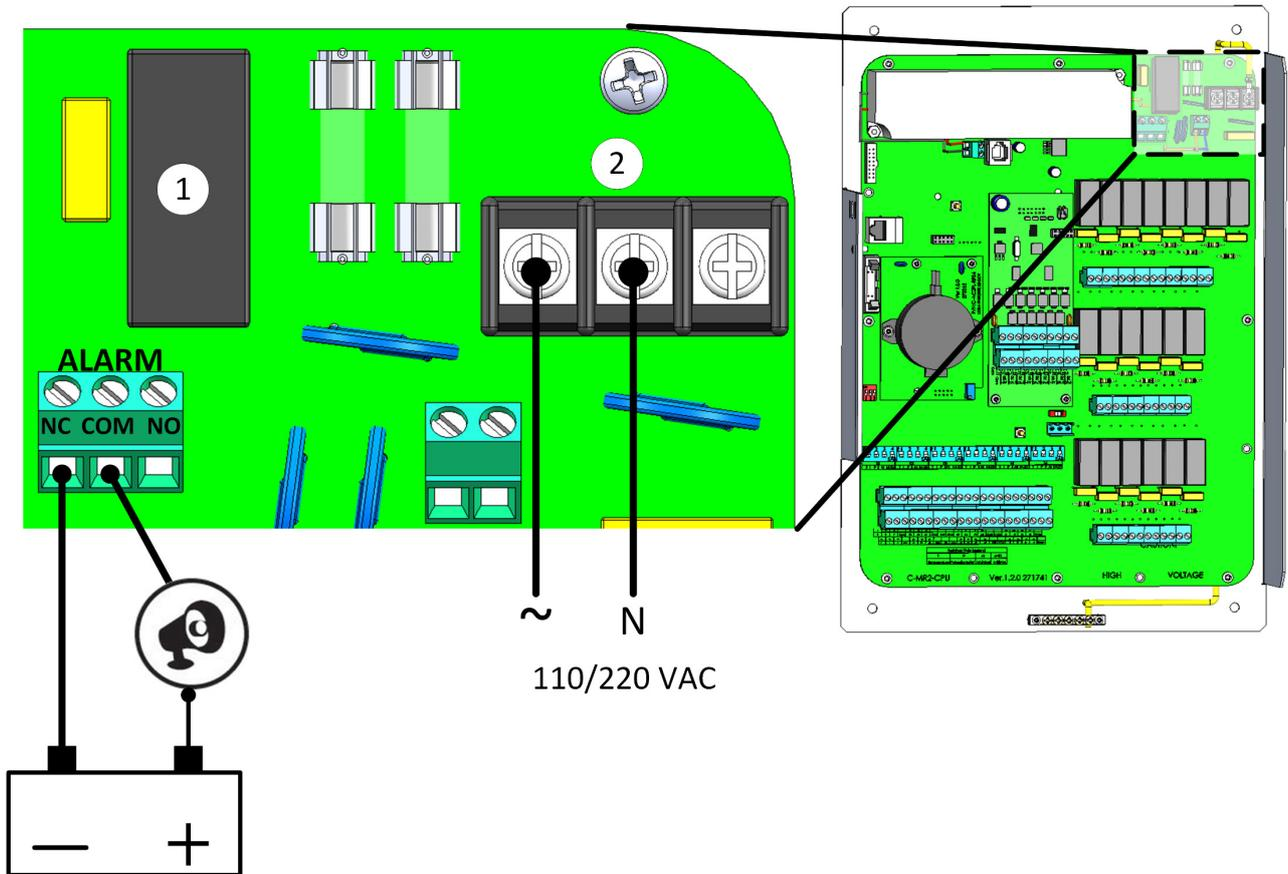

Figure 50: Alarm relay and power ports

| | |
|---|-------------|
| 1 | Alarm relay |
| 2 | Power ports |

13.1.7 GROUNDING

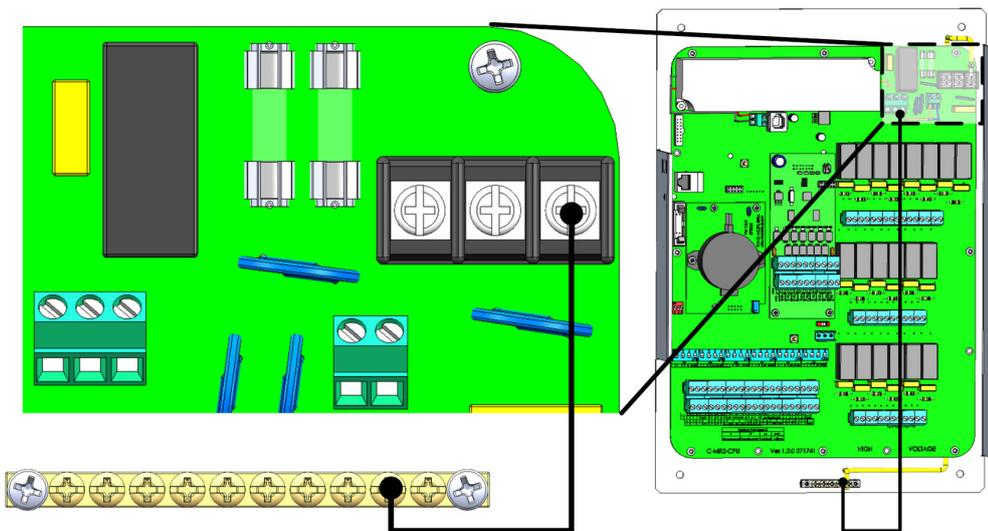

Figure 51: Grounding

CAUTION The unit must be grounded at all times!

13.2 Trio Expansion Panel Mount Installation

The Trio Expansion Panel Mount (940-10-10001/8 TRIO EXP PAN-MUR-NO10) consists of two elements, connected by flat ribbons and internet cable:

- Front panel (CPU panel)
- Rear panel Expansion Relay / card panel

- Precautions
- Panels
- Panel Dimensions
- Panel to Panel Expansion Wiring

13.2.1 PRECAUTIONS

Ensure the following:

- The setup meets electrical, mechanical and fire enclosure requirements.
- Clearance and creepage distances are maintained.
- Grounding meets industry standards.
- Ambient temperatures do not go above product requirements (50° C).
- Ensure that no contactors are in that closet. Placing this unit in proximity to contactors results in severe signal interference.

13.2.2 PANELS

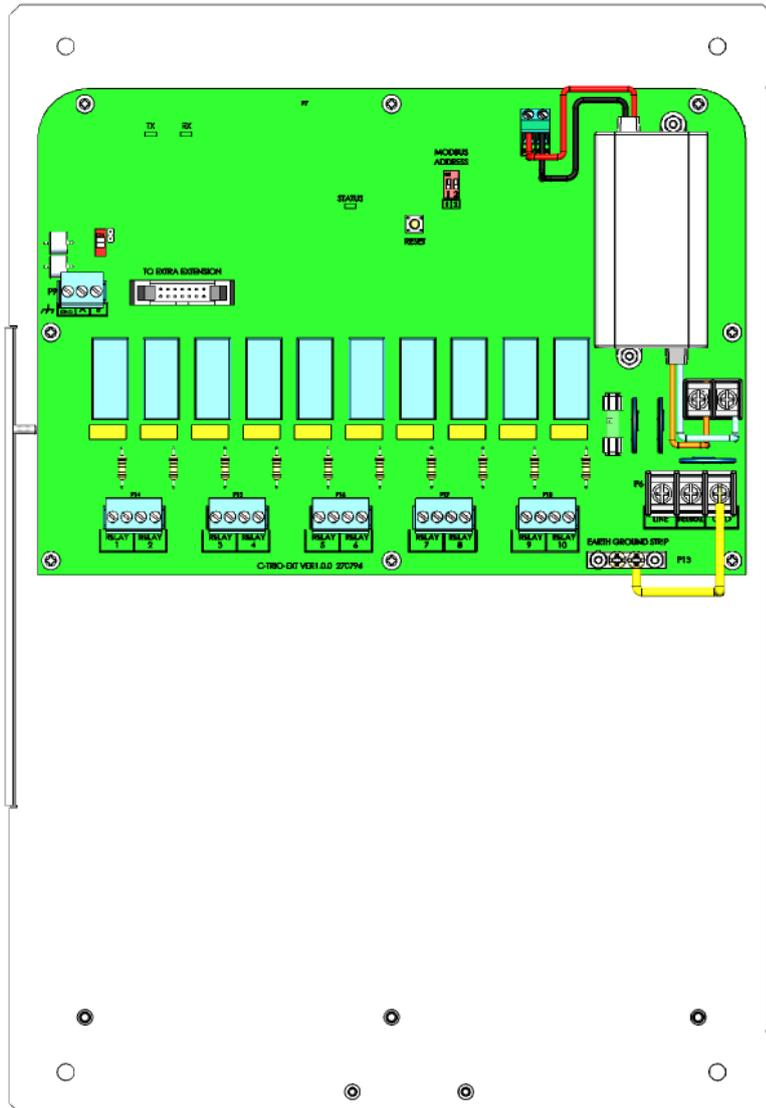

Figure 52: Trio Expansion Relay Panel, Front View

13.2.3 PANEL DIMENSIONS

Distances are in millimetres.

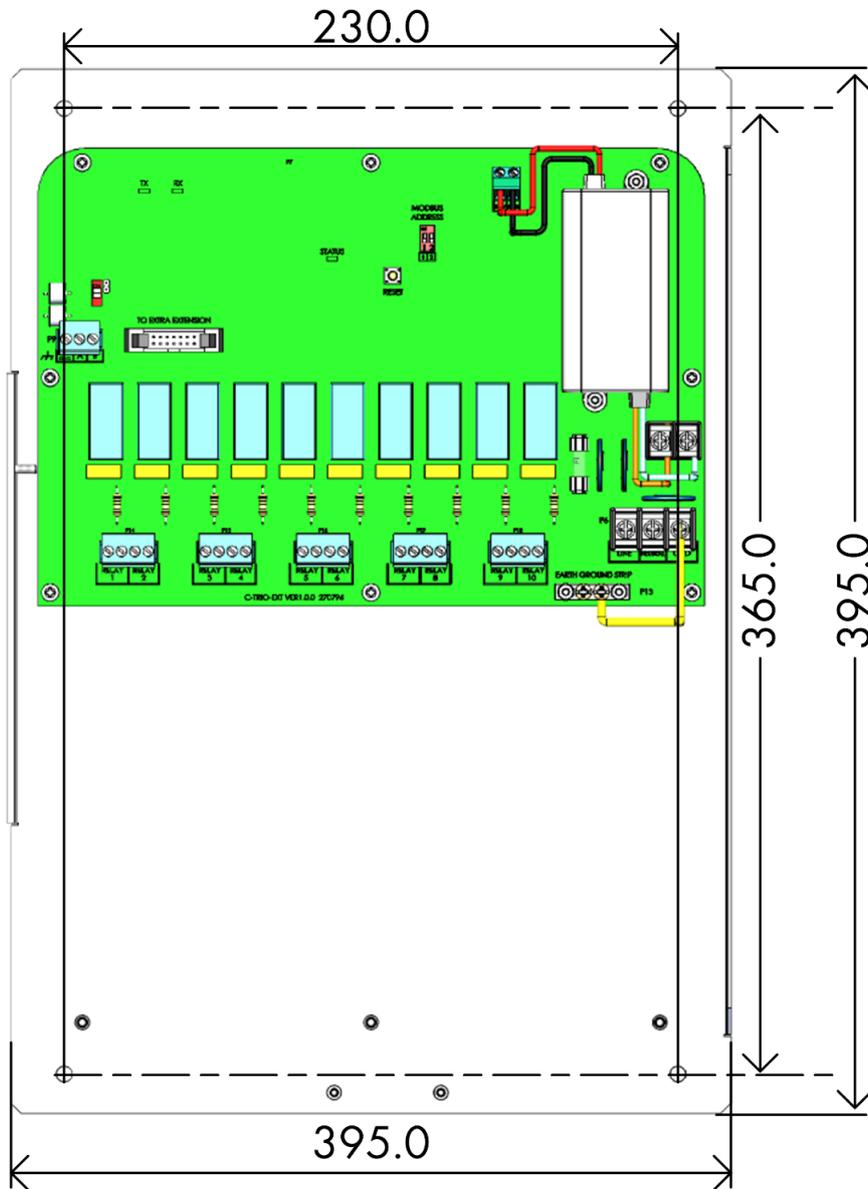

Figure 53: Expansion Rear Panel Dimensions

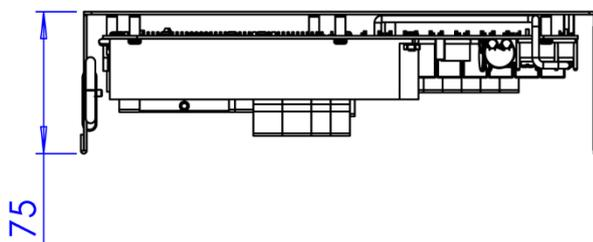

Figure 54: Rear Panel Depth Dimensions

13.2.4 PANEL TO PANEL EXPANSION WIRING

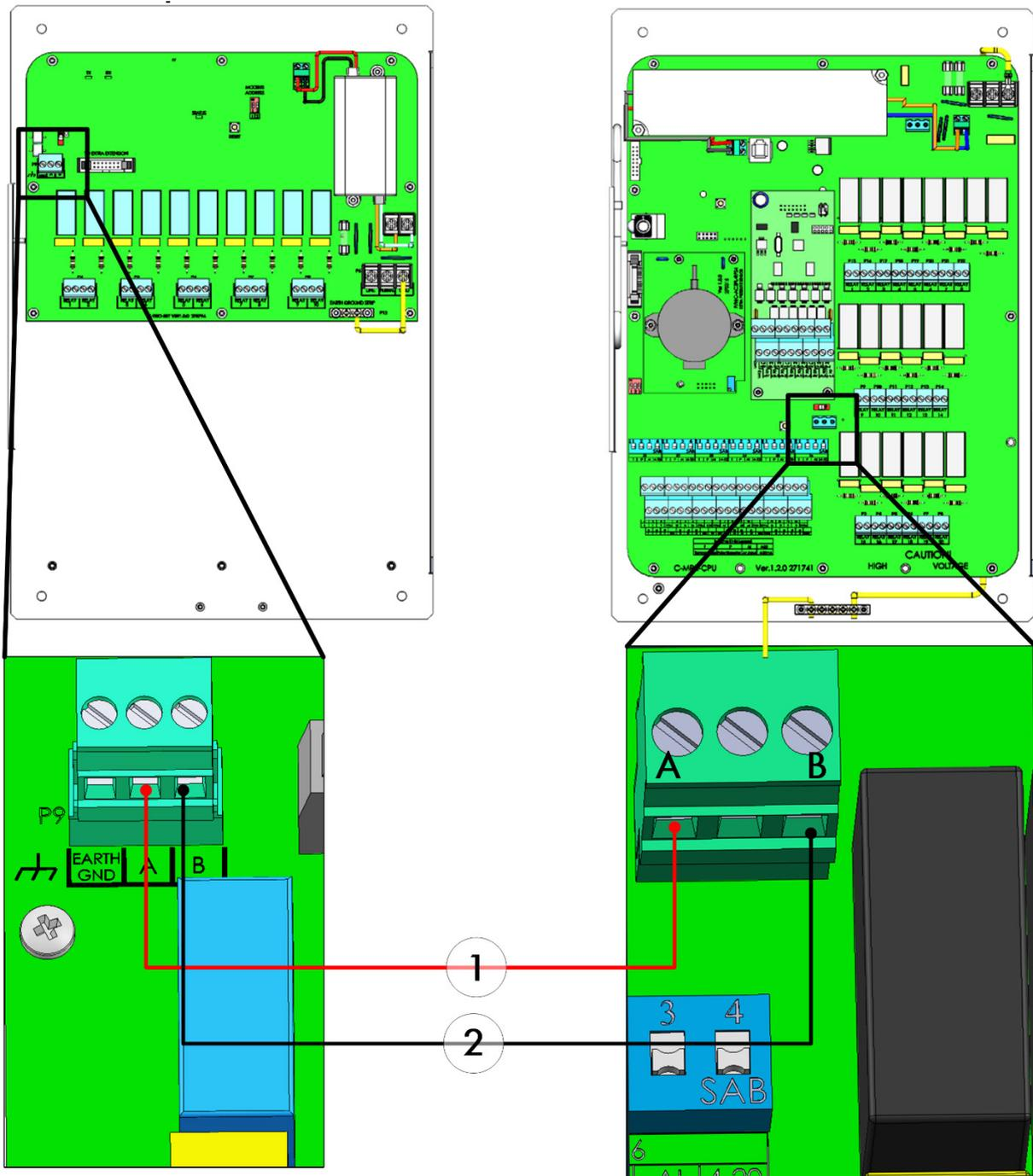

Figure 55: Panel Mount/Expansion Panel Mount Wiring

- The cable between the controller and the expansion unit should be a 4-wire twisted shielded cable (22 or 24 AWG).
- 1 – red wire
- 2 – black wire

13.2.5 POWER

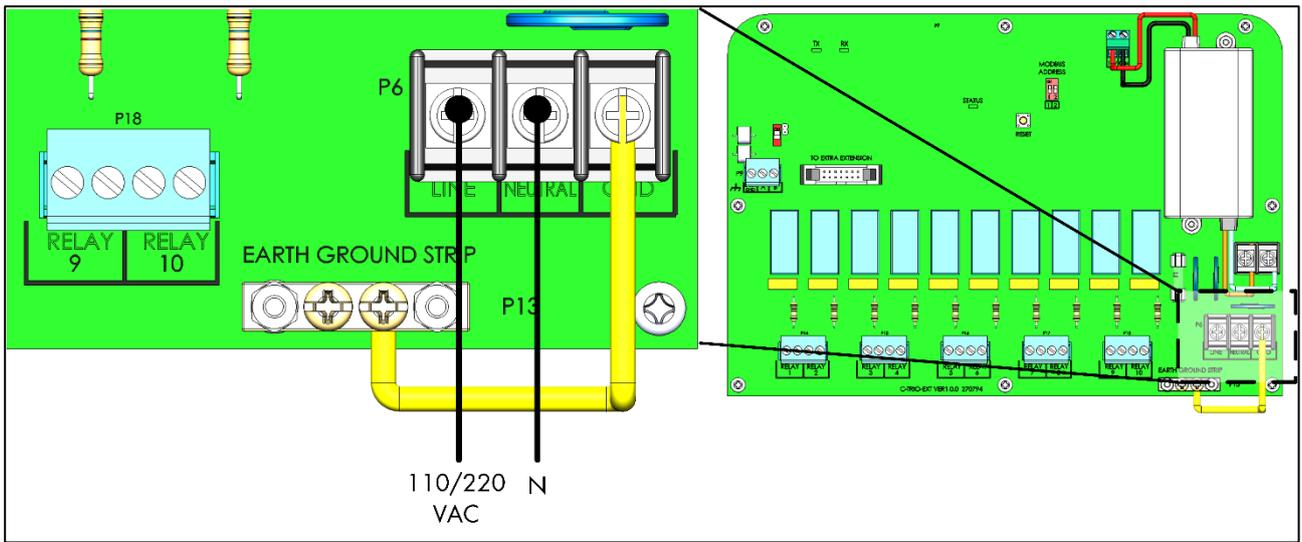
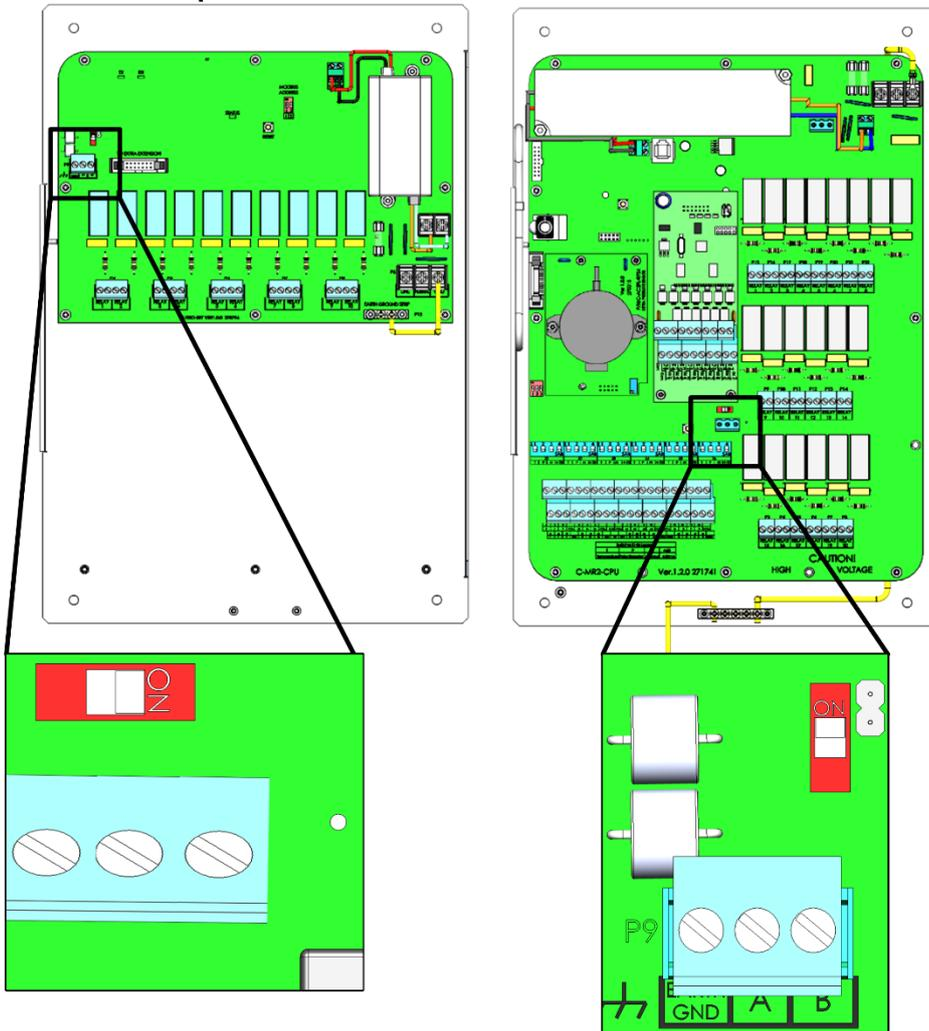

Figure 56: Power ports

13.2.6 TRIO PANEL / TRIO PANEL EXPANSION TERMINATION

When Trio Panel is wired to a Trio Panel Expansion unit, the termination dipswitch in both units must be set to ON.



NOTE When the Trio Panel is not wired to an Expansion device, the termination dipswitch position is irrelevant.

14 Warranty

Warranty and technical assistance

Munters products are designed and built to provide reliable and satisfactory performance but cannot be guaranteed free of faults; although they are reliable products they can develop unforeseeable defects and the user must take this into account and arrange adequate emergency or alarm systems if failure to operate could cause damage to the articles for which the Munters plant was required: if this is not done, the user is fully responsible for the damage which they could suffer.

Munters extends this limited warranty to the first purchaser and guarantees its products to be free from defects originating in manufacture or materials for one year from the date of delivery, provided that suitable transport, storage, installation and maintenance terms are complied with. The warranty does not apply if the products have been repaired without express authorisation from Munters, or repaired in such a way that, in Munters' judgement, their performance and reliability have been impaired, or incorrectly installed, or subjected to improper use. The user accepts total responsibility for incorrect use of the products.

The warranty on products from outside suppliers fitted to Trio, (for example antennas, power supplies, cables, etc.) is limited to the conditions stated by the supplier: all claims must be made in writing within eight days of the discovery of the defect and within 12 months of the delivery of the defective product. Munters has thirty days from the date of receipt in which to take action, and has the right to examine the product at the customer's premises or at its own plant (carriage cost to be borne by the customer).

Munters at its sole discretion has the option of replacing or repairing, free of charge, products which it considers defective, and will arrange for their despatch back to the customer carriage paid. In the case of faulty parts of small commercial value which are widely available (such as bolts, etc.) for urgent despatch, where the cost of carriage would exceed the value of the parts, Munters may authorise the customer exclusively to purchase the replacement parts locally; Munters will reimburse the value of the product at its cost price.

Munters will not be liable for costs incurred in demounting the defective part, or the time required to travel to site and the associated travel costs. No agent, employee or dealer is authorised to give any further guarantees or to accept any other liability on Munters' behalf in connection with other Munters products, except in writing with the signature of one of the Company's Managers.

WARNING: In the interests of improving the quality of its products and services, Munters reserves the right at any time and without prior notice to alter the specifications in this manual.

The liability of the manufacturer Munters ceases in the event of:

- dismantling the safety devices;
- use of unauthorised materials;
- inadequate maintenance;
- use of non-original spare parts and accessories.

Barring specific contractual terms, the following are directly at the user's expense:

- preparing installation sites;
- providing an electricity supply (including the protective equipotential bonding (PE) conductor, in accordance with CEI EN 60204-1, paragraph 8.2), for correctly connecting the equipment to the mains electricity supply;
- providing ancillary services appropriate to the requirements of the plant on the basis of the information supplied with regard to installation;
- tools and consumables required for fitting and installation;
- lubricants necessary for commissioning and maintenance.

It is mandatory to purchase and use only original spare parts or those recommended by the manufacturer.

Dismantling and assembly must be performed by qualified technicians and according to the manufacturer's instructions.

The use of non-original spare parts or incorrect assembly exonerates the manufacturer from all liability.

Requests for technical assistance and spare parts can be made directly to the nearest [Munters office](#).

