

AX and GB Series

36" Tilt Fans with
Galvanized Cone

Instruction Manual

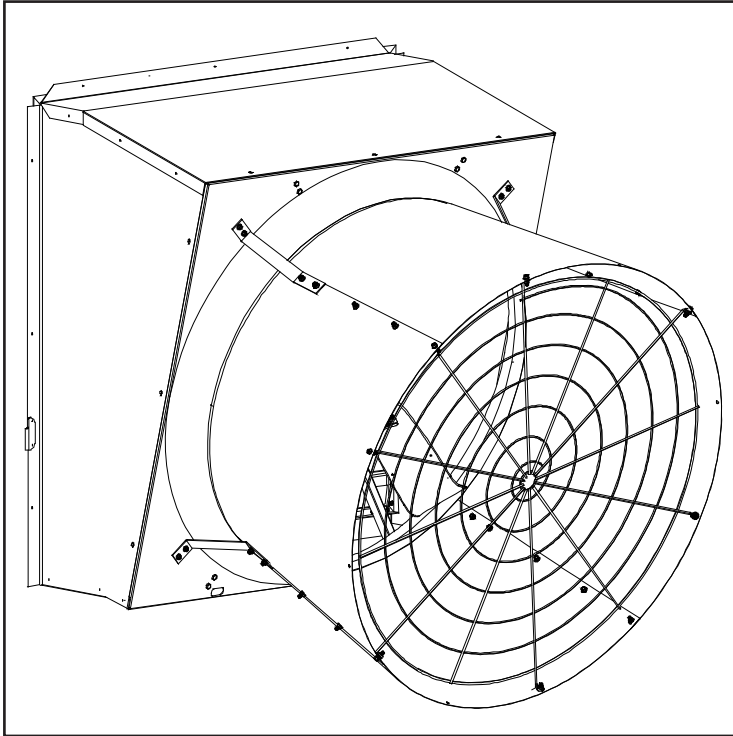

AX and GB Series 36" Tilt Fan

with Galvanized Cone

Models: AX36Tx • AX36xTx • GB36Tx • GB36xTx



AX and GB Series 36" Tilt Fan with Cone

Instructions for Use and Maintenance

Thank You:

Thank you for purchasing a AX/GB Series Tilt Fan. Munters equipment is designed to be the highest performing, highest quality equipment you can buy. With the proper installation and maintenance it will provide many years of service.

Please Note:

To achieve maximum performance and insure long life from your Munters product it is essential that it be installed and maintained properly. Please read all instructions carefully before beginning installation.

Warranty:

For Warranty claims information see the "Warranty Claims and Return Policy" form QM1021 available from the [Munters Corporation office at 1-800-227-2376 or by e-mail at aghort.info@munters.com](mailto:aghort.info@munters.com).

Conditions and Limitations:

- Products and Systems involved in a warranty claim under the "Warranty Claims and Return Policy" shall have been properly installed, maintained and operated under competent supervision, according to the instructions provided by Munters Corporation.
- Malfunction or failure resulting from misuse, abuse, negligence, alteration, accident or lack of proper installation or maintenance shall not be considered a defect under the Warranty.

Index

Chapters	Page
1. Unpacking the Equipment	4
1.1 Parts List	4
1.2 Dimensions	5
2. Installation Instructions	6
3. Electrical Wiring	9
3.1 Electrical Wiring	9
3.2 Recommended Wire Routing	10
4. Operation	11
5. Maintenance	12-13
6. Winterizing	14
7. Troubleshooting	15
8. Exploded View and Parts List	16-17

Unpacking the Equipment

1.

Before beginning installation, check the overall condition of the equipment. Remove packing Materials and examine all components for signs of shipping damage. Any shipping damage is the customers responsibility and should be reported immediately to your freight carrier.

1.1 Parts List

Each Crate Includes:

- 1 - 36" Belt Drive or Direct Drive fan
- 4 - Cone Sections
- 4 - Cone Support Brackets
- 1 - Cone Guard
- 1 - Shutter
- 1 - Hardware Package (HP1098):

HP1098 - Hardware Package for 36" Tilt Fan

ID	Qty.	Cat. No.	Description
[A]	12	KS2463	1/4" x 1.5" Hex Lag Screw, ZP
[B]	16	KS1153	1/4"-20 x 1/2" SRTD HX Flange Head Bolt, ZP
[C]	12	KS1151	1/4"-20 x 3/4" SRTD HX Flange Head Bolt, ZP
[D]	28	KN0730	1/4"-20 SRTD HX Flange Nut, ZP
[E]	8	KS2260	1/4"-20 x 3/4" SRTD HX Washer TEK Screw, ZP

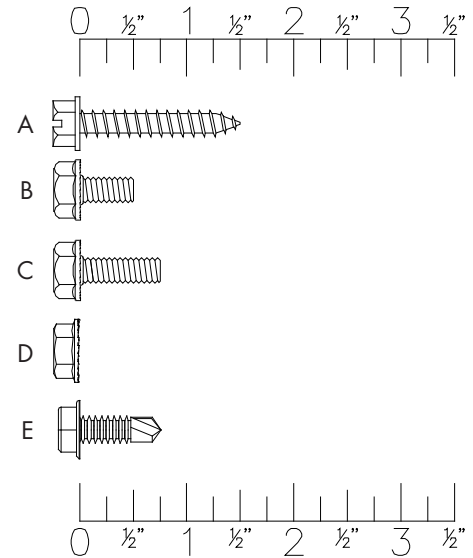

1.2 Fan Dimensions

Fan Specifications: 60Hz shown (50Hz available)

Power: 120/240 VAC or 208-240/480 VAC

Phase: 1 or 3

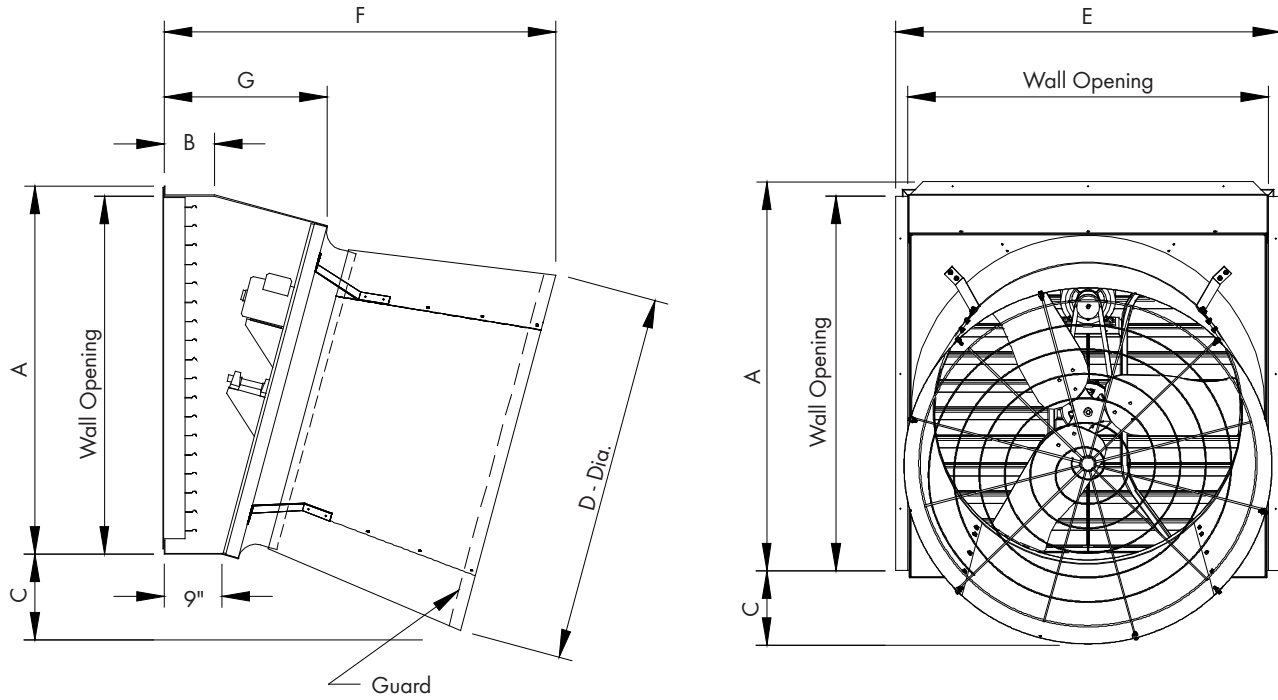

Dimensions:

Cat. No.	Fan Dia.	A	B	C	D - Dia.	E	F	G	Wall Openings (I.D., Framed)
AX/GB36T	36"	45 ¹ / ₄ "W. x 45 ³ / ₄ "H.	6"	12 ³ / ₁₆ "	43 ¹ / ₂ "	44 ³ / ₄ "	46 ³ / ₈ "	19 ⁵ / ₁₆ "	43"W. x 45"H.
AX/GB365T	36"	45 ¹ / ₄ "W. x 45 ³ / ₄ "H.	6"	12 ³ / ₁₆ "	43 ¹ / ₂ "	44 ³ / ₄ "	46 ³ / ₈ "	19 ⁵ / ₁₆ "	43"W. x 45"H.

Installation Instructions

2.

2.1 Installation

Step 1

Construct a framed opening to correct size according to Wall Opening listed in chart on previous page and your fan size. See Figure 1.

Recommended Clearance*



- Fan with outlet guard: maintain 8" minimum clearance on all sides
- Fan with discharge cone: maintain 12" minimum clearance on all sides

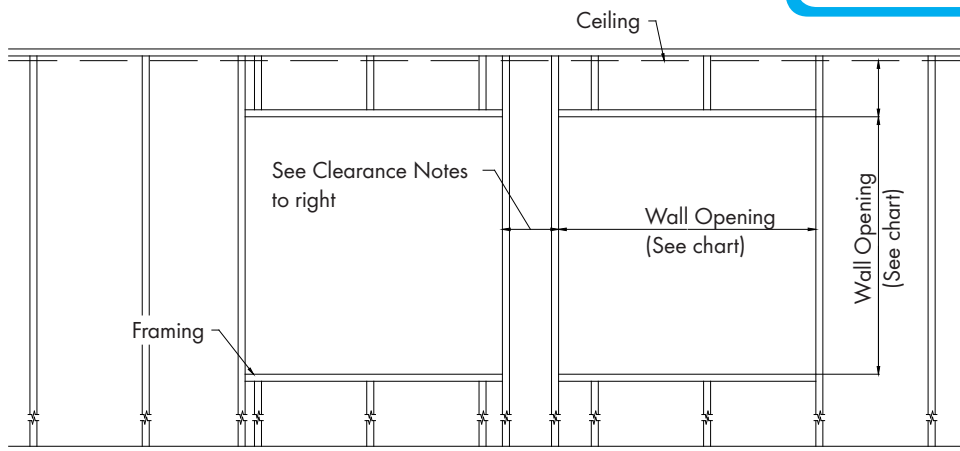

Figure 1

Step 2

Insert fan into framed opening from the inside. See Figure 2.

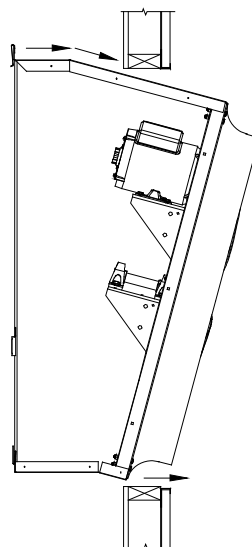
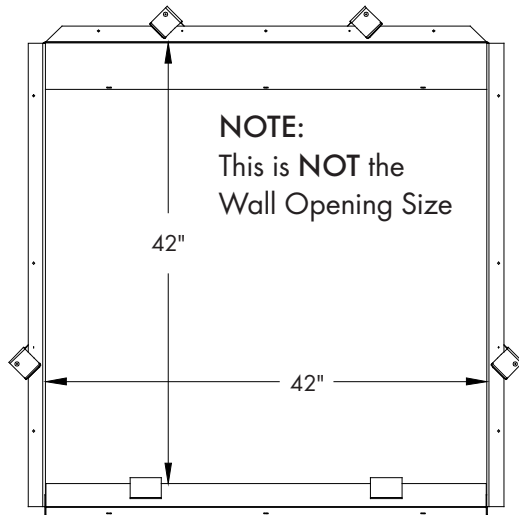

Figure 2

Step 3

Confirm that housing inside dimensions match those shown in [Figure 3A](#). Then secure housing to framing using (12) Lag Screws [A]. See [Figure 3B](#).



[Figure 3A](#)

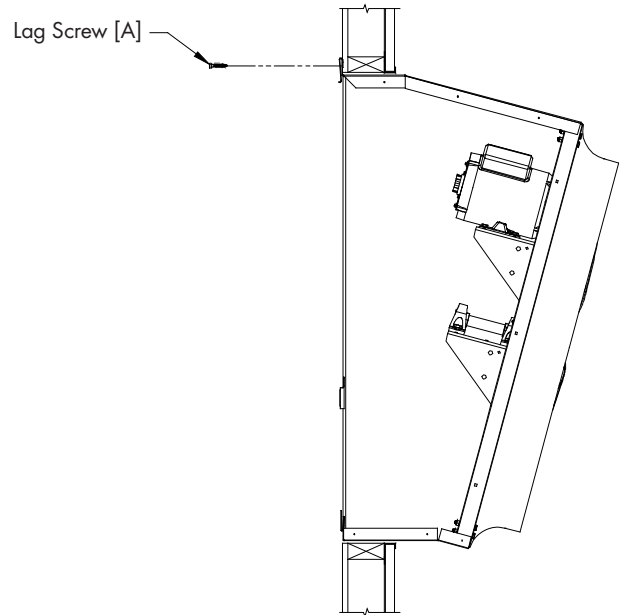

[Figure 3B](#)

Step 4

Proceed to the installation instructions for the Discharge Cone, Form [QM1023](#). Once Discharge Cone is completed, proceed to Electrical Wiring Section before the Shutter Installation.

Step 5

Add flashing and/or caulk around completed housing on exterior side of building wall.

Step 6

Make electrical connections to fan motor per instructions provided with fan or as shown on motor.

Step 7

Insert shutter into fan by sliding the bottom flange of shutter into bottom shutter clips and pressing shutter inward, *See Figure 4A*. Fasten shutter in place by rotating the side and top shutter clips over the shutter flanges. *See Figure 4B*.

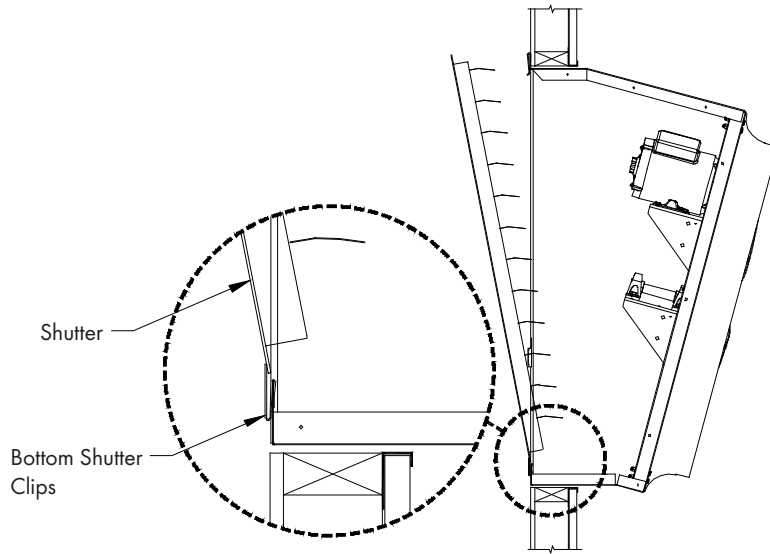

Figure 4A

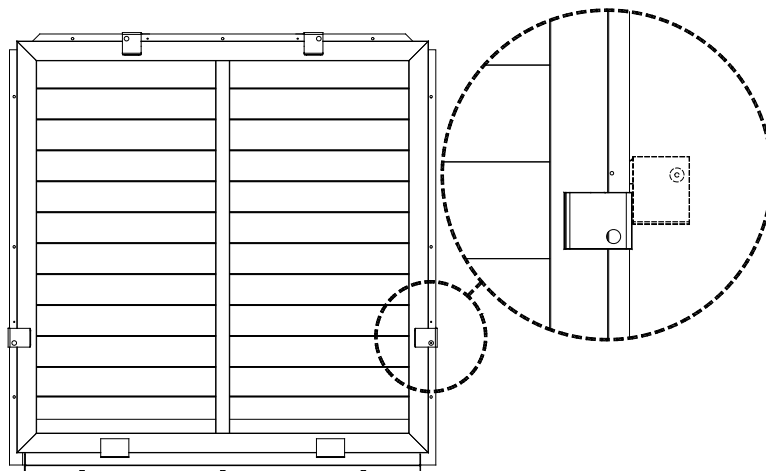

Figure 4B

3.1 Electrical Wiring

All wiring should be installed in accordance with National, State, and Local electrical codes. Fans used to ventilate livestock buildings or other rooms where continuous air movement is essential should be connected to individual electrical circuits, with a minimum of two circuits per room. For electrical connection requirements, refer to diagram on motor nameplate and to information enclosed with the environmental control to be used.

Single Phase Fans: motor overload protection should be provided for each fan. A Circuit Breaker Switch or slow blow motor type fuses must be used [See Figure 5A](#). See QM1400 for proper size.

Three Phase Fans: motor overload protection should be provided for each fan. A three pole motor starter or slow blow motor fuses must be used. [See Figure 5B](#).

If a frequency drive (inverter) is used, confirm that motors are rated for inverter duty at the voltage used. The installation of line reactors is recommended to reduce voltage spikes and harmonic distortion. Supplemental motor overload protection is also recommended.

NOTE: A safety cut-off switch should be located adjacent to each fan.

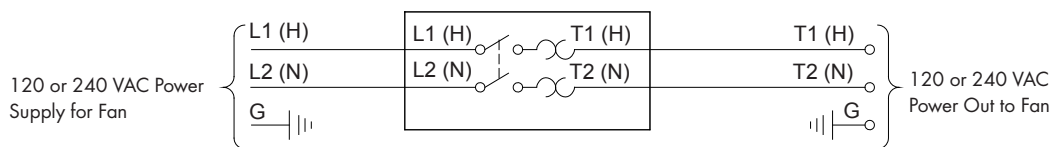

Figure 5A

Single Phase - Motor Overload Protection with Disconnect
(SY2000 or Equivalent)

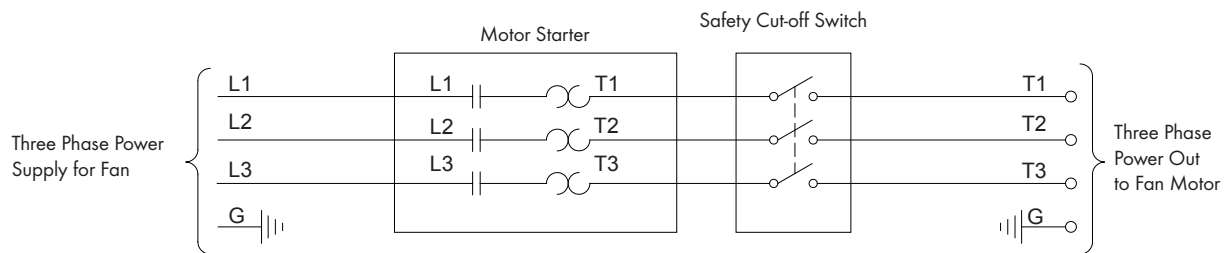

Figure 5B

Three Phase - Motor Overload Protection with Disconnect

KEY:

L1 = Line 1

L2 = Line 2

L3 = Line 3

H = Hot

N = Neutral

G = Ground

Note:

Information in parenthesis refers to 120 VAC control.

3.2 Recommended Wire Routing

Step 7

As the power cable exits the back of the motor, form a Drip Loop and then run power cable down along strut and "zip tie" the cable to strut to prevent cable from getting tangled in pulley or belt. [See Figure 6.](#) Then run cable out the drain hole to the circuit breaker or control panel.

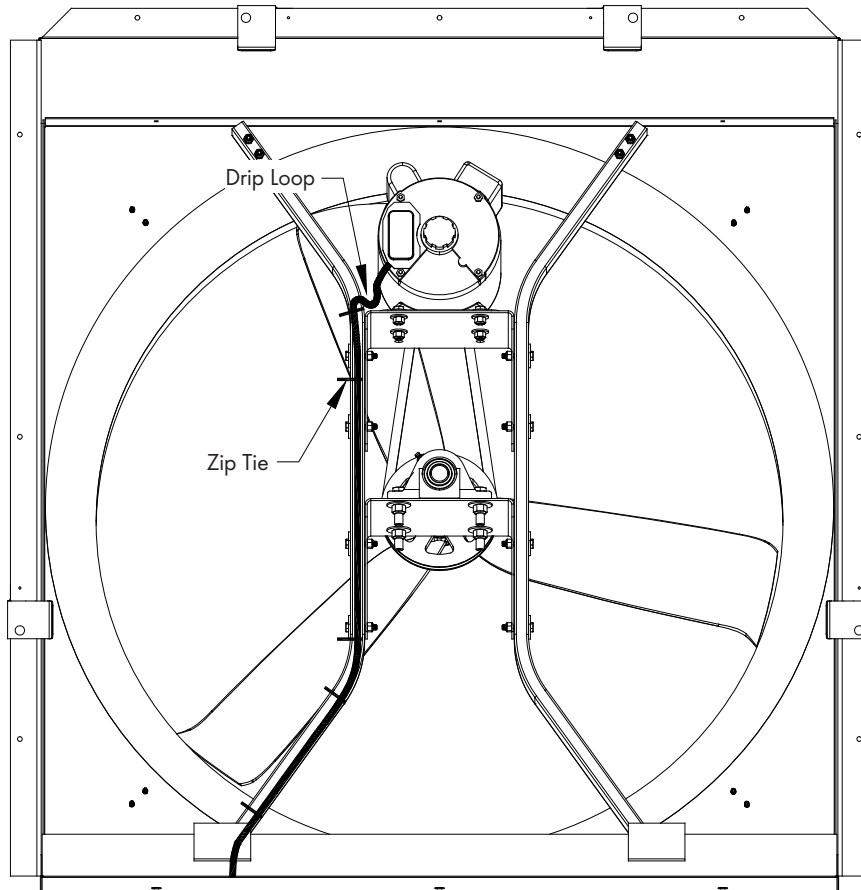

Figure 6

Operation

4.

4.1 Operation

INITIAL START-UP: With electrical power off, verify that the fan propeller turns freely and that all fasteners are secure. Turn on electrical power and confirm that the fan operates smoothly.

ADJUSTMENTS: Set the fan control to the temperature shown on your ventilations system drawing, or to a value which will provide the desired environmental conditions.

Single Phase Fans: When variable speed controls are used, the fan's idle speed will need to be set to the recommended minimum airflow rate. Refer to the procedures included with each control. The table below provides airflow rates at various propeller speeds for fans wired for 240 VAC.

CFM	A = Fan with cone & shutter				B = Fan with hood & shutter			
	0.02" Static Pressure				0.05" Static Pressure			
	A		B		A		B	
	RPM	VOLTS	RPM	VOLTS	RPM	VOLTS	RPM	VOLTS
750	—	—	—	—	—	—	350	121
1000	—	—	—	—	370	123	390	128
1250	330	117	330	119	390	127	410	130
1500	360	123	360	125	410	131	430	134
1750	370	125	370	127	425	136	440	136
2000	380	128	390	130	450	137	460	139
2500	410	131	420	135	470	141	480	143
3000	430	135	440	138	490	145	500	146
4000	470	142	480	145	520	149	530	151
5000	520	148	530	152	560	156	570	158
6000	560	154	580	159	590	161	600	162
7000	610	159	640	165	640	166	680	172
8000	650	166	700	173	690	172	750	179
9000	710	172	760	185	740	178	810	209
10,000	770	179	840	225	790	195	—	—
11,300	840	223	—	—	—	—	—	—

Three Phase Fans:

- 1) The use of a quality frequency drive and the installation of line reactors is recommended to reduce voltage spikes and harmonic distortion.
- 2) Minimum operating frequency of 30 Hz.
- 3) Will require three pole contactors with overload protection (by others).
- 4) 36" Direct Drive, 3 Phase fan is not suitable for frequency drive.



5.1 Maintenance

The following inspection and cleaning procedures should be performed monthly:

Tools Needed for Maintenance:

wrenches: 17mm, 27mm, 5/32" Allen

- 1) **INSPECT PROPELLER:** Check that propeller is secure on prop shaft or motor shaft and that there are no signs of damage. The blades are of a self-cleaning design and should not require maintenance.
- 2) **CLEAN** regularly for best results:
 - **FAN MOTOR:** Remove any dust accumulation from motor using a brush or cloth. (DO NOT use a pressure washer). A clean motor will run cooler and last longer. At the same time, verify that the motor is secure in its mount.
 - **SHUTTER:** Carefully clean dust from damper doors and frame so that doors open and close freely. A brush or cloth should be used.
 - **GUARD:** Clean any dust or feathers from fan guards using a brush. Dirty guards can reduce airflow.
- 3) **CHECK FASTENERS:** For safety, all fasteners should be inspected 1 month after initial operation and yearly thereafter. Tighten any loose connections.
- 4) **INSPECT FAN CONTROL:** With power disconnected, inspect all electrical connections. Wiring should be secure and in good condition. Remove any dust build-up from control case and sensor using a soft brush or cloth. **NEVER CLEAN ELECTRICAL EQUIPMENT WITH A PRESSURE WASHER!**
- 5) **GREASE BEARINGS:** Grease bearings every 4-6 months. Use no more than 2 shots when greasing fan.
 - A premium non-water based grease is recommended:
 - Shell Alvania #2
 - Mobil Mobilux #2
 - Exxon Unirex N2
 - Texaco Premium RB
 - Mobil 532
 - Texaco Multifak #2

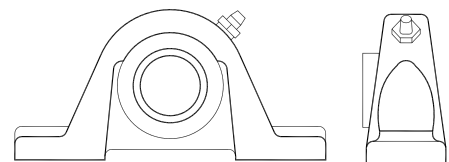

- 6) **CHECK DRIVE ALIGNMENT:** Check to make sure the belt is centered on the idler pulley, then use a straight edge to check the alignment of the drive pulleys. If an adjustment is needed, remove the belt, then loosen the set screw in one pulley and move it. Remember to tighten the set screw after making an adjustment. Drive alignment is very important for long belt life and proper operation.

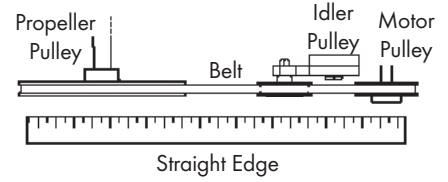

- 7) **CHECKING PULLEYS:** Roll the belt off and look at both pulleys. If the pulley has grooves in it or is no longer smooth, it needs replacement. A loose or slipping belt will reduce fan performance up to 60% and cause premature belt failure.

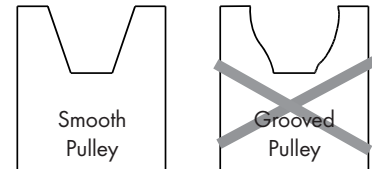

- 8) **BELT TENSIONING:**
All belts must be checked for proper tension after the first 3 days of fan operation and every 4-6 months thereafter.

Solid Belt

To adjust the belt tensioner to the proper setting, loosen 10 mm bolt fastening tensioner to bracket (using 17mm end wrench) to allow tensioner arm to rotate. Working from inlet/motor side of fan, place a 27 mm (1 1/8") wrench onto the hex on the tensioner. Turn wrench counterclockwise until the single mark on base of the belt tensioner is aligned with mark 4 on the tensioner arm. Hold tensioner at this setting and tighten the 10mm bolt to 40 ft. lbs. [54 N-m] torque.

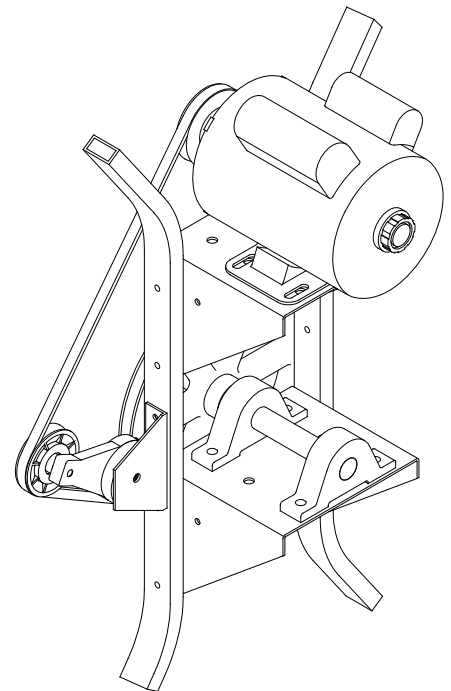

AeroLink Belt

- Roll the belt off the pulleys by forcing it sideways off the larger pulley as you turn the drive by hand.
- Reinstall the belt by wrapping it around the smaller pulley and then starting it over the larger pulley.
- As you continue rolling it onto the larger pulley, the belt should become taut in the position shown below.
- If the belt becomes taut before reaching the position shown, add one link and try again.
- If the belt is loose when in the position shown, remove one link and try again.

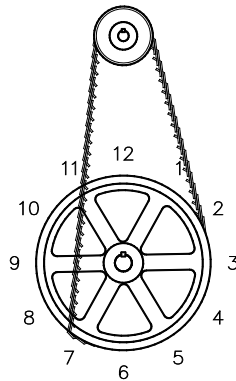
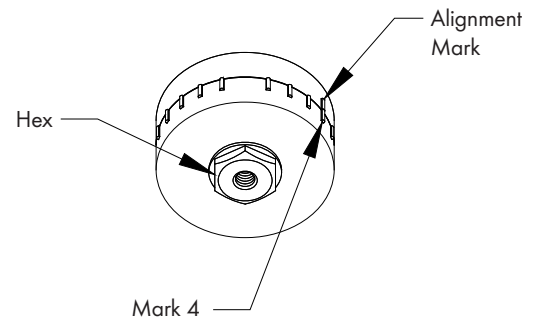

6.1 Winterizing

In most climates, it is probable that the ventilation system will never need to operate at a total capacity during the colder winter months. Consequently, it is advisable to “winterize” those fans which will not be used in cold weather to avoid unnecessary heat loss and condensation.

To winterize, turn fan control “off”. Install the insulated closure panel over the fan intake. If you don’t have an insulated closure panel, a piece of rigid insulation material can be used. Remember the insulation panel must be removed before warmer weather returns.

NOTE: At least one single speed fan should be left uncovered and with power available to provide air movement in the event of variable speed control difficulties.



SYMPTOM	POSSIBLE CAUSES	CORRECTIVE ACTION
Fan Not Operating	<ol style="list-style-type: none"> 1. Fan control set above room temperature 2. Blown fuse or open circuit breaker 3. Propeller blade contacting fan housing 4. Fan control defective 5. Motor defective 	<ol style="list-style-type: none"> 1. Set to a lower temperature 2. Replace fuse or reset breaker 3. Realign motor in fan housing 4. Repair or replace control 5. Repair or replace motor
Fan Operating- Insufficient Airflow	<ol style="list-style-type: none"> 1. Shutter jammed 2. Guard dirty 3. Frequency drive improperly adjusted 4. Incorrect Belt Tension/worn belt 	<ol style="list-style-type: none"> 1. See operation, Step 2 for adjustments guidelines 2. Clean guard 3. See operation, Step 2 for adjustments guidelines 4. See Maintenance Section, Belt Tensioning
Excessive Noise	<ol style="list-style-type: none"> 1. Propeller blade contacting fan housing 2. Motor bearing or shaft bearing defective 3. Frequency drive improperly adjusted 4. Variable speed control defective 	<ol style="list-style-type: none"> 1. Adjust bearing position to realign propeller 2. Repair or replace motor or shaft bearings 3. See operation, Step 2 for adjustments guidelines 4. Repair or replace control
Excessive Vibration	<ol style="list-style-type: none"> 1. Motor loose on mount 2. Propeller damaged 3. Motor Shaft Bent 	<ol style="list-style-type: none"> 1. Tighten fasteners 2. Replace propeller 3. Repair or replace motor or propeller shaft
Fan never turns off	<ol style="list-style-type: none"> 1. Override thermostat set incorrectly 2. Control set for continuous operation 	<ol style="list-style-type: none"> 1. Set to the correct temperature 2. Set speed control correctly

Exploded View

8.

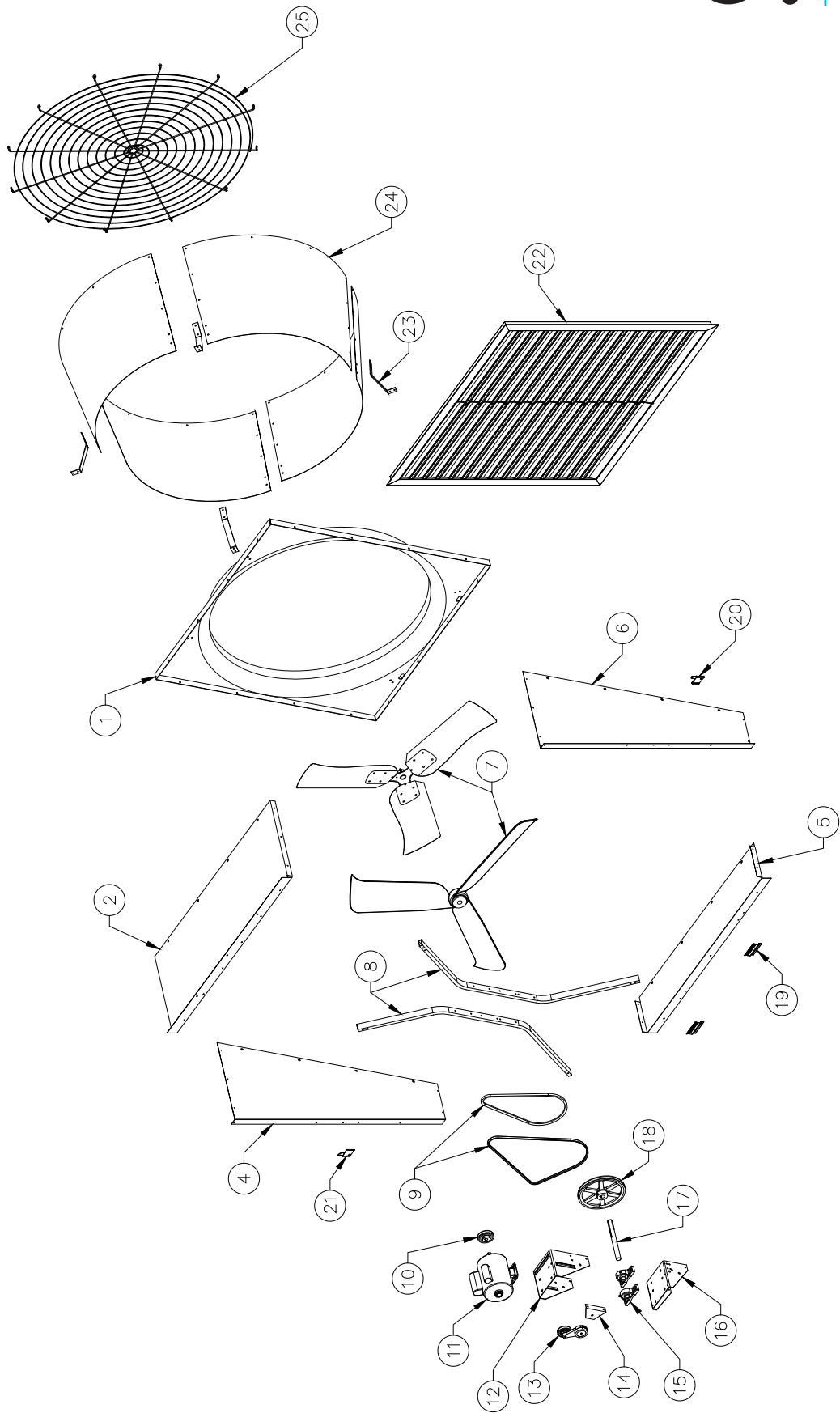

Item	Catalog No.				Part Name/Description	QTY
	GB36Tx	AX36Tx	GB365Tx	AX365Tx		
1	FH3136	FH1248	FH1248	FH1248	Orifice Panel, GZ	1
2	FH2278	FH2278	FH2278	FH2278	Top Housing Panel, GZ	1
4	FH2276	FH2276	FH2276	FH2276	Left Housing Panel, GZ	1
5	FH2279	FH2279	FH2279	FH2279	Bottom Housing Panel, GZ	1
6	FH2277	FH2277	FH2277	FH2277	Right Housing Panel, GZ	1
7	FP1041	–	FP1041	–	Propeller, 3 - Blade, GZ	1
	–	FP1013SS	–	FP1014SS	Propeller, 3 - Blade, AL	1
8	FH2094	–	–	–	Angle Style Strut, 36"GB, GZ	2
	–	FH2436	FH2436	FH2436	Tube Strut, GZ	2
9	–	–	FH2083*	FH2083*	Link Belt	1
	–	–	FH1470*	FH1470*	V-Belt, A-Section	1
10	–	–	FH2003*	FH2031*	Motor Sheave, CI	1
11	FM1048*	FM1022*	FM1011*	FM1022*	Motor	1
12	–	FH2825	FH2815	FH2815	Motor Support, CTD-GZ	1
13	–	–	FH2402K	FH2402K	Belt Tensioner Assembly with 3" idler pulley	1
	–	–	FH2406	FH2406	3" idler pulley only, with bolt	1
	–	–	FH2439	FH2439	Tensioner Arm only, AL	1
14	–	–	FH2504	FH2504	Mounting Bracket for Belt Tensioner, GZ	1
15	–	–	FH2057	FH2057	Bearing, 1" Bore x 1.44"CL, CI Holder	2
16	–	–	FH2815	FH2815	Bracket, Bearing Mount, GZ	1
17	–	–	FH2086	FH2101	Shaft, Steel	1
18	–	–	FH2091*	FH2033*	Propeller Sheave, CI	1
19	FH2123	FH2123	FH2123	FH2123	Shutter Support Bracket, GZ	2
20	FH2119	FH2119	FH2119	FH2119	Shutter Clip, Right, SS	2
21	FH2117	FH2117	FH2117	FH2117	Shutter Clip, Left, SS	2
22	PZ36	PZ36	PZ36	PZ36	Shutter, All Plastic	1
23	FH2130	FH2130	FH2130	FH2130	Cone Support Bracket, GC type, GZ	4
24	FH4236	FH4236	FH4236	FH4236	Discharge Cone, (1) Section, GZ	4
25	FH1336	FH1336	FH1336	FH1336	Guard Kit, 365FC/36GC Cone, PVC CTD	1

* Contact office for replacement part numbers for your fan configuration.

AX/GB Series Tilt Fans are developed and produced by Munters Corporation, Lansing, Michigan U.S.A. 1-800-227-2376



Munters Europe AB, Isafjordsgatan 1, P.O. Box 1150, SE-164 26 Kista, Sweden. Phone +46 08 626 63 00, Fax +46 8 754 56 66.

Munters Corporation 2691 Ena Drive Lansing, MI 48917 U.S.A. Phone +1 800-227-2376, Fax +1 517-676-7078

www.munters.us

[Australia](#) Munters Pty Limited, Phone +61 2 6025 6422, [Brazil](#) Munters Brasil Industria e Comercio Ltda, Phone +55 41 3317 5050, [Canada/US](#) Munters Corporation Lansing, MI Phone +1 517 676 7070, [China](#) Munters Air Treatment Equipment (Beijing) Co. Ltd, Phone +86 10 80 481 121, [Denmark](#) Munters A/S, Phone +45 9862 3311, [India](#) Munters India, Phone +91 20 3052 2520, [Indonesia](#) Munters, Phone +62 818 739 235, [Italy](#) Munters Italy S.p.A., Chiusavecchia, Phone +39 0183 52 11, [Japan](#) Munters K.K., Phone +81 3 5970 0021, [Korea](#) Munters Korea Co. Ltd., Phone +82 2 761 8701, [Mexico](#) Munters Mexico, Phone +52 818 262 54 00, [Russia](#) Munters AB, Phone +7 812 448 5740, [Singapore](#) Munters Pte Ltd., Phone +65 744 6828, [South Africa and Sub-Sahara Countries](#) Munters (Pty) Ltd., Phone +27 11 997 2000, [Spain](#) Munters Spain S.A., Phone +34 91 640 09 02, [Sweden](#) Munters AB, Phone +46 8 626 63 00, [Thailand](#) Munters Co. Ltd., Phone +66 2 642 2670, [Turkey](#) Munters Form Endüstri Sistemleri A.Ş, Phone +90 322 231 1338, [USA](#) Munters Corporation Lansing, MI Phone +1 517 676 7070, [Vietnam](#) Munters Vietnam, Phone +84 8 3825 6838, [Export & Other countries](#) Munters Italy S.p.A., Chiusavecchia Phone +39 0183 52 11