

Installation manual

SMT



SMT Inlet shutter

SMT 24

SMT 30

SMT 36

SMT 50

SMT 60

Munters reserves the right to make alterations to specifications, quantities, dimensions etc. for production or other reasons subsequent to publication.

The information contained herein has been prepared by qualified experts within Munters. While we believe the information is accurate and complete, we make no warranty or representation for any particular purpose. The information is offered in good faith and with the understanding that any use of the units or accessories in breach of the directions and warnings in this document is at the sole discretion and risk of the user.

Contents

1. CE Declaration	4
1.1 Disclaimer	5
1.2 Introduction	5
1.3 Notes	5
2. Before using	6
2.1 Delivery check	6
2.1 Packaging and transport of assembled shutters	6
2.3 Structure	6
3. Operating condition	7
4. Installation	7
4.1 Placement of shutters	7
4.2 Electrical wiring	8
5. Commissioning	9
6. Safety aspect	10
6.1 General	10
7. Technical data	11
7.1 Dimensions	11
7.2 Technical specification	11
7.3 Damper specification	11
8. Maintenance	12
8.1 introduction	12
8.2 Cleaning	12
8.3 Actuator replacement	12
9. Spare part list	14

1. CE Declaration

Conformity Declaration



Munters Italy Spa
Strada Piani 2
Chiusavecchia (IM)

Declares that the equipment model:
SMT24 – SMT30 – SMT36 – SMT50 – SMT60

Are in compliance to the safety requirements according to the current laws:

- D.Lgs. 459/96
- D.Lgs. 626/96

And that the following norms have been applied

- CEI EN 60335-1
- UNI EN 292
- UNI EN 294

Chiusavecchia (IM), 01/03/2007

Managing Director
Vasco Olivi

A handwritten signature in black ink, appearing to read 'Vasco Olivi', is written over the printed name.

1.1 Disclaimer

Munters reserves the right to make alternations to specifications, quantities, dimensions etc. for production or other reasons, subsequent to publication.

The information contained herein has been prepared by qualified experts within Munters.

While we believe the information is accurate and complete, we make no warranty or representation for any particular purposes. The information is offered in good faith and with the understanding that any use of the units or accessories in breach of the directions and warnings in this document is at the sole discretion and risk of the user.

1.2 Introduction

Congratulations on your excellent choice of purchasing a Munters shutter!

In order to realise the full benefit from this product it is important that it is installed, commissioned and operated correctly. Before installation or using the shutter, this manual should be studied carefully. It is also recommended that it is kept safely for future reference.

The manual is intended as a reference for installation, commissioning and day-to-day operation of the Munters shutter.

1.3 Notes

Date of release: March 2007.

Munters cannot guarantee to inform users about the changes or to distribute new manuals to them.

All rights reserved. No part of this manual may be reproduced in any manner whatsoever without the expressed written permission of Munters.

The contents of this manual are subject to change without notice.

2. Before Using

2.1 Delivery check

Upon receipt, inspect the shutter for external damage and if found, inform the forwarding agent without delay. Check the data on all the rating plates, especially voltage and frequency.

2.2 Packaging and transport of assembled shutters

The shutter has a self-supporting structure in galvanised steel and it is usually delivered without packaging. Upon request shutters can be delivered packed in cardboard boxes.

Shutters should not be permanently stocked one upon the other, regardless if they are delivered with or without packaging. Handling of the shutters should not be done manually as the shutters have no handles or grips. Consequently one of the following alternatives should be used:

Forklift: Before loading, make sure the forks are opened as much as possible to avoid bending of the shutter bottom panel.

Crane: Fix two bolts in the M8 bushes situated on the angle brackets of the shutter housing and hook the lifting cable over the bolts.



WARNING!

Make sure a steel cable or rope of adequate size is being used when the shutter is lifted by crane. Shutter weights are shown in the technical specification table (section 7.2).

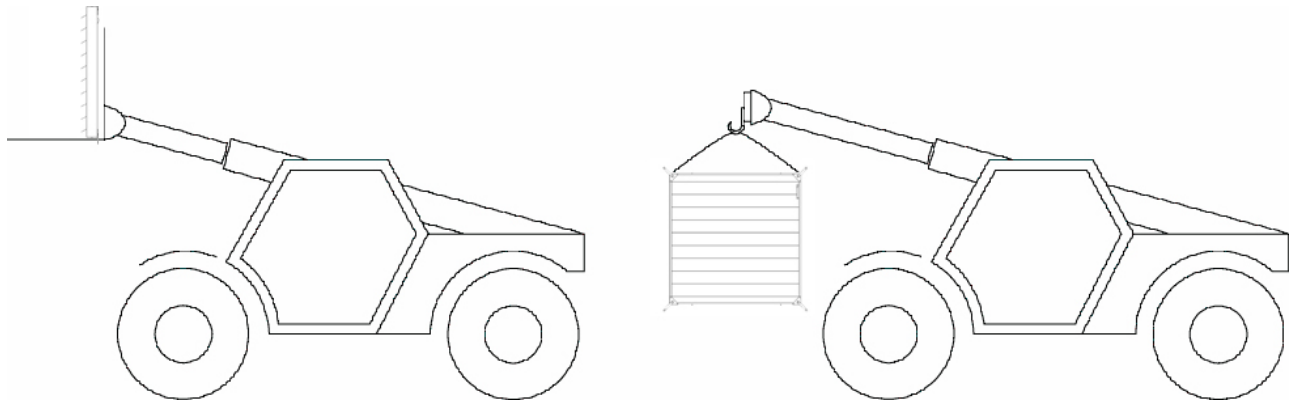

2.3 Structure

The shutters consist of the following components:

- Shutter housing in galvanised steel without welding spots;
- Shutter blades in galvanised steel which pivot on UV protected plastic bushes and pins.
- Damper actuator: see technical specification table (section 4.2)
- Pyramidal shape and flat meshes for protection on back and front side.
- Strong fixing brackets. To be used to fix the shutter in to the wall.
- Opening arm for shutter serial connected (optional extra). To be used when the you need to connect more shutter by using one actuator.

3. Operating Conditions

The shutters, such as the SMT, are products that allowed air exchange inside the structure which helps to cool animals down during hot periods. Normal ambient temperature limits are -30°C to $+50^{\circ}\text{C}$.

4. Installation

4.1 Placement of shutters

Before starting the mounting procedure of the shutter check the opening of the shutter blades manually unlocking the actuator by using the magnetic tool. Then reset the magnetic tool in working position.

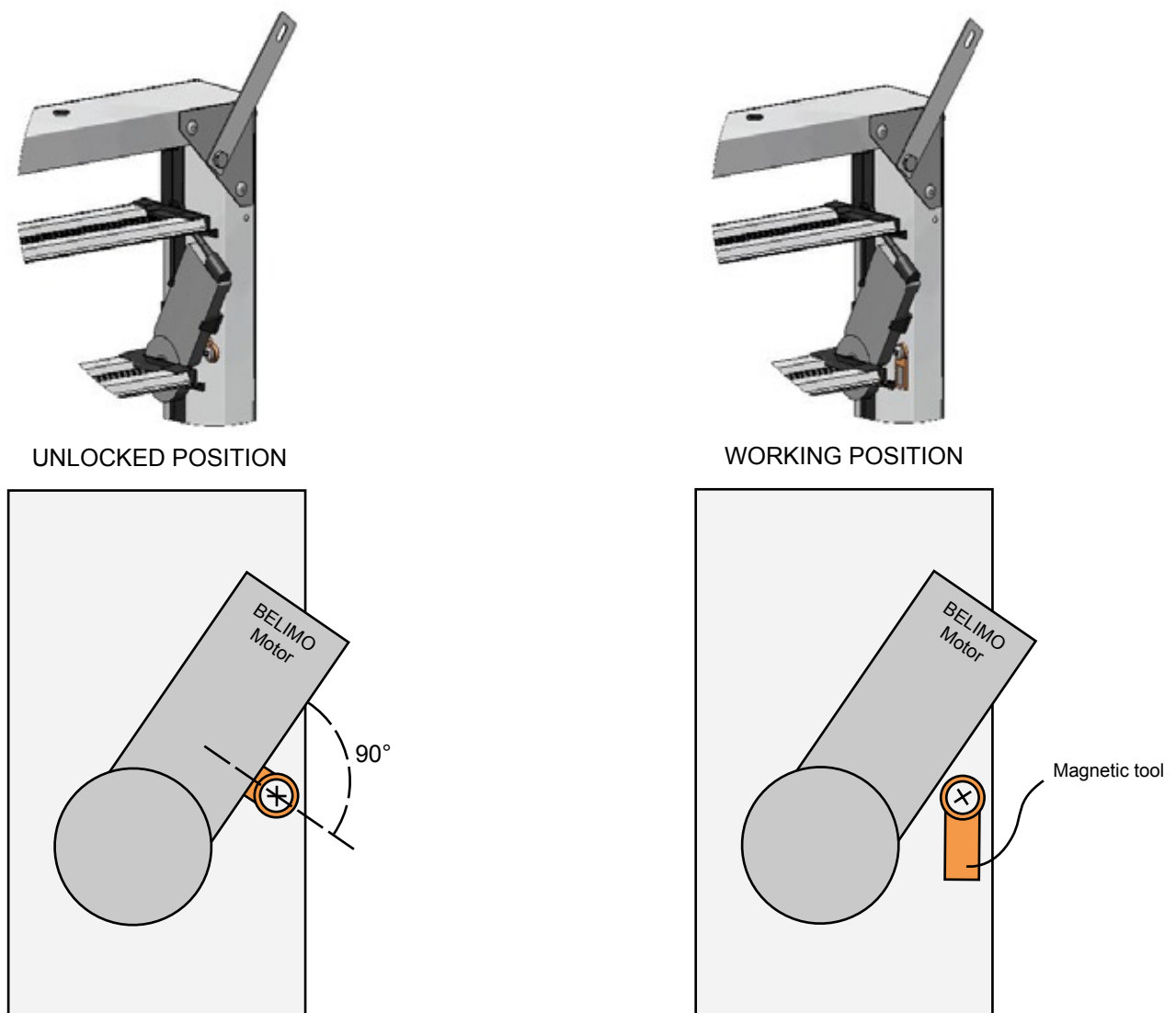

After creating the hole in the wall following the dimension table (section 7.1) fix the shutter in to the wall by using its brackets and bolt supplied and qty 4 fisher plugs.

If the shutter is equipped with the opening arm for shutter serial connected please take care to fix the bracket and the pulley by mean of the same bolts.

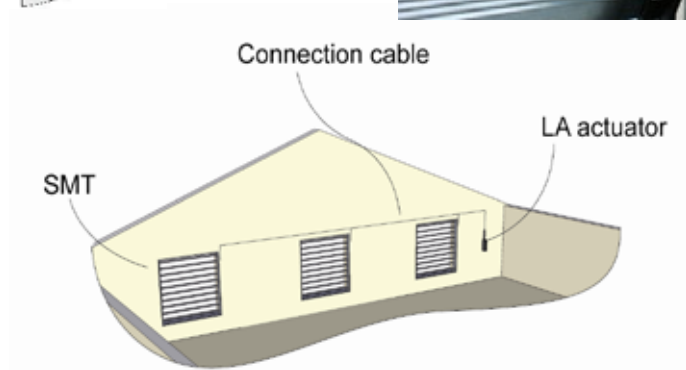

4.2 Electrical wiring

The shutter is delivered without an electrical control box, but the shutter motor comes already wired. Connection to the power supply must be done by means of a thermal overload protection switch, whose size depends on motor power. For safety reasons the overload switch can be locked by a padlock, not supplied by Munters.

The installer must provide a suitable control box in compliance with requirements specified by EN 60204 rules. Electrical earthing must be carried out according to local regulations before the motor is connected to the supply voltage.

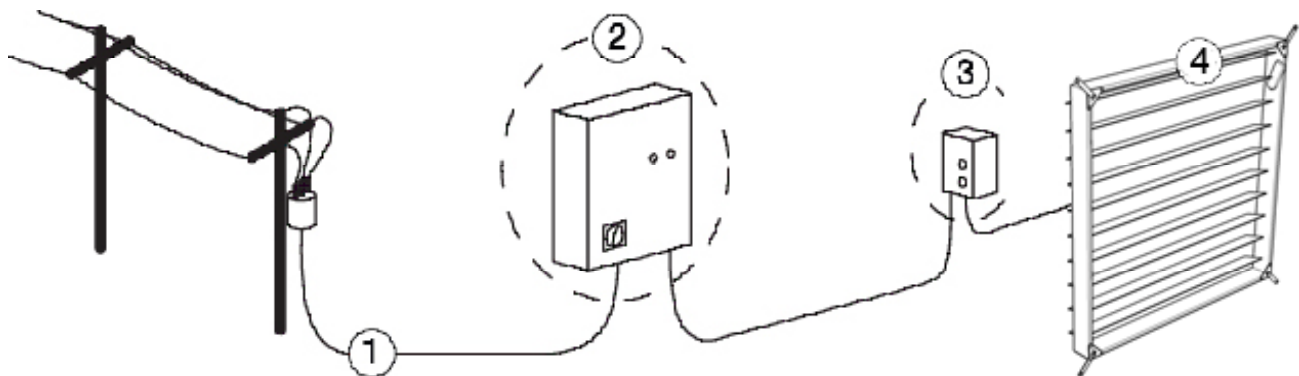

1. Mains electrical supply
2. Main electrical enclosure
3. Local motor starter near shutter
4. Shutter

Below are suggested wiring diagrams for connecting the shutter to the mains electrical supply. These diagrams are however subject to local laws and regulations and should be modified if necessary to comply with such laws and regulations.

AC 24 V / DC 24 V

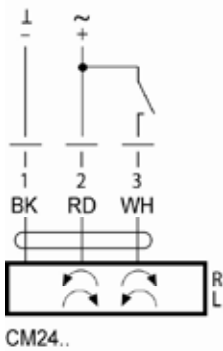

AC 230 V

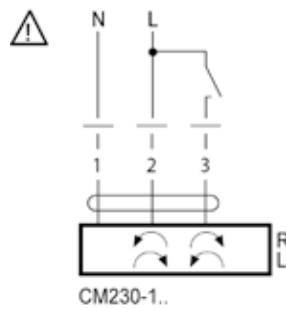

AC 24 V / DC 24 V

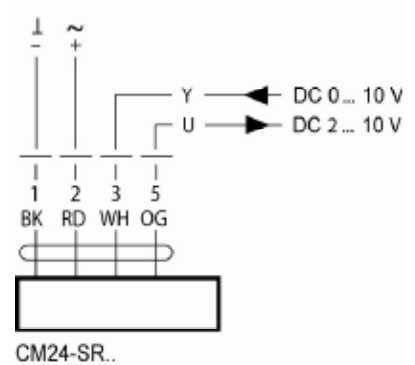

WARNING!

The connection cable must be completely extracted from the shutter housing in order to avoid being damaged by moving parts.

Standard shutter motors have the following voltage and frequency:

- 230 V one-phase 50 Hz.

For other voltage option see section 7.3.

Technical specifications are written on the label stuck on the actuator. Before operating the shutter, make sure the actuator turns in the direction you desire.

To change the direction of rotation of the actuator it is necessary to change the connection as shown in the above diagram.

5. Commissioning

After installation, follow the steps mentioned below to verify that the shutter is working properly.

1. Check if all the shutters are secured tightly to the wall;
2. Ensure that all the necessary safety equipment is fitted to the shutters;
3. Ensure that all electrical connections are done properly and comply with local regulations;
4. Remove all obstacles from the front and back sides of the shutters;
5. Ensure that all people and animals are standing clear of the shutters;
6. Turn the electrical power to the shutters on;
7. Observe the direction in which the shutter blades are turning to ensure that it is in the same direction as you desire;
8. Turn the electrical power to the shutters off;



WARNING!

Do not attempt to correct any problem observed during the above mentioned steps while the shutter is in operation. Wait until the electrical power has been switched off and the shutter has come to a complete stand still. Lock the electrical switch in the off position with a pad lock while working on the shutter.

6. Safety Aspects

6.1 General

The safety of shutters is assured by Munters in compliance with the safety requirements indicated by the CE label. Safe functioning is assured only when the installation procedure and the instructions for use have been carefully followed. The following points must be stressed:

- Proper transport procedure must be followed.
- Do not remove the safety mesh guards.
- The maintenance operator must be kept informed on maintenance procedures.
- Do not operate the shutter without having it firmly fixed to the structure or without complying with the safety regulations for the electrical connection.
- Do not install the shutter in places where there might be explosion hazards as described by EN 60079 rules.
- Do not handle any material which might produce explosive powders.
- The emission of harmful particles and / or gases into the atmosphere must be within the limits determined by local authorities.
- The shutter is intended to be installed and used by qualified personnel who are familiar with relevant safety requirements.
- Safety equipment necessary for the prevention of accidents at the mounting and operating site shall be provided by the buyer in accordance with the regulations prevailing in the local country.
- Shutters should not be installed in places where children aged 14 years or less are present.

7 Technical Data

7.1 Dimensions

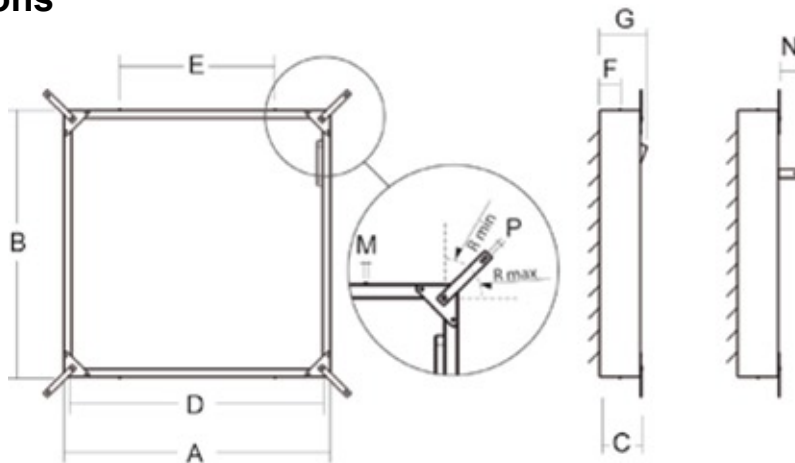

SMT code	Dimensions [mm]											
	A	B	C	D	E	F	G	M	N	P	R max	R min
24	745	735	100	644	354	38	115	M8	43	7	130	120
30	950	995	100	847	557	38	115	M8	43	7	130	120
36	1090	1085	100	985	695	38	115	M8	43	7	130	120
50	1380	1380	100	1264	987	38	115	M8	43	7	130	120
60	1380	475	100	1264	987	38	115	M8	43	7	130	120

7.2 Technical specifications

SMT code (size)	24	30	36	50	60
Weight (with motor actuator) [Kg]	8,5	12	14	20	10,5
No. of shutter blades	5	7	8	10	3
Inlet opening [m ²]	0,45	0,8	1,02	1,7	0,53

7.3 Damper specifications

Code	230	24	24SR
Power supply	AC 230V, 50/60 Hz single phase	AC 24V, 50/60 Hz or DC 24 V	AC 24 V, 50/60 Hz
Regulation signal			DC 0 - 10 V
Power consumption	1,5W	0,5W	1W
For wire sizing	3,5VA	1VA	2VA
Direction of rotation	Selected with L/R switch		
IEC protective class of electric motor	IP54		
Ambient temperature	-30 +50 °C		
Ambient humidity	95% RH, non condensating according to EN 60730-1		

8. Maintenance

8.1 Introduction

Maintenance must only be carried out by qualified personnel only using suitable tools and working methods. Before any maintenance steps are taken, make sure the power switch is in the off position and locked by a padlock.

Make sure the shutter blades are at a complete stand still.



Shutters do not contain parts needing periodic lubrication, as moving parts are either manufactured from self lubricating materials, or, are sealed with lifetime lubrication.

8.1 Cleaning

Inspect the shutter at regular intervals and keep it clean. It is advised to perform periodic cleaning of safety mesh guards when they are installed. Dust on the safety mesh guards causes extra power consumption; severe dust on the motor can cause overheating and subsequent motor failure.

To clean all the parts of the shutter it is suggested to use a soft brush and / or compressed air. In order to avoid damage to the electric motor, cleaning the motor directly with water jets must be avoided.

8.3 Actuator replacement

If damage occurs to the propeller, it is necessary to replace the whole propeller because of the difficulty to balance it in the field.

How to replace the actuator:

1. Starting point.
2. Rotate the magnet to the override position underneath the motor (see page 6).
3. Unscrew the blade in the middle length position.
4. Remove the blade support.
5. Remove the blade support.
6. Unscrew the two nuts keeping the two halves of the blade together.
7. Remove/replace the motor.
8. Replace the blade support.
9. Replace the blade half blade and join it with the other half using the two bolts and nuts. Turn the magnet away from the override position back to the resting position (as in step 1).



1. Starting point



2. Rotate the magnet to the override position underneath the motor (see page 6)



3. Unscrew the blade in the middle length position



4. Remove the blade



5. Remove the blade support



6. Unscrew the two nuts keeping the two halves of the blade together



7. Remove/replace the motor



8. Replace the blade support



9. Replace the blade half blade and join it with the other half using the two bolts and nuts. Turn the magnet away from the override position back to the resting position (as in step 1)

9. Spare Part List

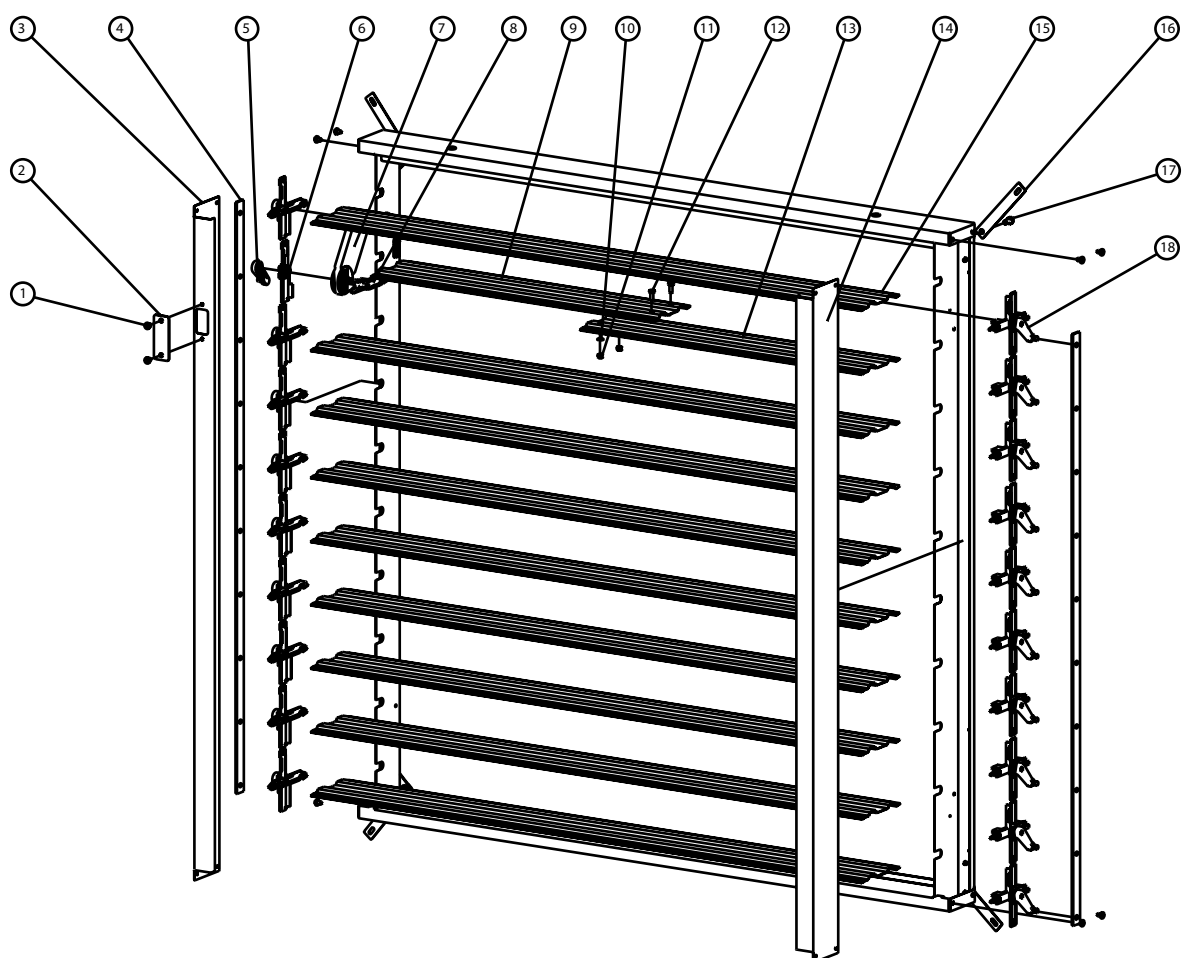

Common parts

Position	Article Number	Description
1	2278600	Self tapping hex screw Ø 6.3 X 13mm
2	2450370	Cap for cover plate
5	2266100	Plastic handle
6	2266060	Left plastic bearing for actuator
7	see section 7,3	Actuator
8	2265260	Left plastic pin for actuator
10	2277700	Grower Ø 6 mm
11	2273400	Nut M6 x 6 mm
12	2279100	Bolt M6 x 16 mm
16	2450360	Fixing bracket
17	2280600	Nut M8 x 25 mm
18	2524100	Right shutter bearing
19	2524300	Left shutter bearing

SMT 50

Position	Article Number	Description
3	2431750	Left cover plate with inspection hole
4	2455300	Pvc tie-rod with 10 holes
9	2441506	Left short shutter blade 12/10
13	2441505	Right short shutter blade 12/10
14	2431850	Right cover plate
15	2439100	Shutter blade 6/10

SMT 36

Position	Article Number	Description
3	2431960	Left cover plate with inspection hole
4	2457100	Pvc tie-rod with 8 holes
9	2441509	Left short shutter blade 12/10
13	2441508	Right short shutter blade 12/10
14	2431950	Right cover plate
15	2438600	Shutter blade 6/10

SMT 30

Position	Article Number	Description
3	2431560	Left cover plate with inspection hole
4	2455201-K	Pvc tie-rod with 7 holes
9	2441516	Left short shutter blade 12/10
13	2414515	Right short shutter blade 12/10
14	2431550	Right cover plate
15	2437600	Shutter blade 6/10

SMT 24

Position	Article Number	Description
3	2431260	Left cover plate with inspection hole
4	2448500	Pvc tie-rod with 5 holes
9	2441518	Left short shutter blade 12/10
13	2441517	Right short shutter blade 12/10
14	2431250	Right cover plate
15	2438100	Shutter blade 6/10

SMT 60

Position	Article Number	Description
3	2431580	Left cover plate with inspection hole
4	2448400	Pvc tie-rod with 3 holes
9	2441506	Left short shutter blade 12/10
13	2441505	Right short shutter blade 12/10
14	2431570	Right cover plate
15	2439100	Shutter blade 6/10

SMT inlet shutter is developed and produced by Munters S.p.A, Italy



Munters Europe AB, HumiCool Division, Isafjordsgatan 1, P.O. Box 1150, SE-164 26 Kista, Sweden.

Phone +46 08 626 63 00, Fax +46 8 754 56 66.

Munters Italy S.p.A., Strada Piani 2, IT-18027 Chiusavecchia, Italy. Phone +39 0183 52 11, Fax +39 0183 521 333.

www.munters.com

Australia Munters Pty Limited, Phone +61 2 6025 6422, **Brazil** Munters Brasil Industria e Comercio Ltda, Phone +55 11 5054 0150, **Canada** Munters Incorporated, Phone + 1 905 858 5894, **China** Munters Air Treatment Equipment (Beijing) Co., Ltd., Phone +86 10 80 481 121, **Denmark** Munters Turbovent, Phone +45 98623311, **Finland** Munters Oy, Phone +358 9 83 86 030, **France** Munters France S.A., Phone +33 1 34 11 57 50, **Germany** Munters Euroform GmbH, Phone +49 241 89 0 00, **India** Munters India, Phone +91 20 30522520, **Indonesia** Munters Phone +62 21 9105446-7, **Italy** Munters Italy S.p.A., **Chiusavecchia** Phone +39 0183-52 11, Munters Italy S.p.A., **Mondovi** Phone +39 0174 560 600 **Japan** Munters K.K., Phone +81 3 5970 0021, **Kingdom of Saudi Arabia and Middle East** Hawa Munters, Phone +966 1 477 15 14, **Korea** Munters Korea Co., Ltd, Phone +82 2 761 8701, **Mexico** Munters Mexico Phone +52 722 270 40 30, **Russia** Munters Europe AB, Phone +7 812 4485740, **Singapore** Munters Pte Ltd +65 744 6828 **South Africa and Sub-Sahara Countries** Munters (Pty) Ltd, Phone +27 11 971 9700, **Spain** Munters Spain S.A., Phone +34 91-640 09 02, **Sweden** Munters Europe AB, Phone +46 8 626 63 00, **Thailand** Munters (Thailand) Co. Ltd., Phone +66 2 645 2708-12, **United Kingdom** Munters Ltd, Phone +44 845 644 3980, **USA** Munters Corporation **Fort Myers**, Phone +1 239 936 1555, Munters Corporation **Mason**, Phone +1 888 335 0100, **Vietnam** Munters Vietnam Phone +84 8 825 6838
Export & Other countries Munters Europe AB, Phone +46 8 626 63 00

Munters reserves the right to make alterations to specifications, quantities, etc., for production or other reasons, subsequent to publication.

© Munters AB, 2008