

Manual for use and maintenance

USB
RS-485
Driver



USB-RS-485 Driver

Communication Device

USB RS-485 Driver

Manual for use and maintenance

Rev 1.0, 03/2019

Ag/MIS/UmEn-2540-03/18 Rev 1.1 (MIS)

This manual for use and maintenance is an integral part of the apparatus together with the attached technical documentation.

This document is destined for the user of the apparatus: it may not be reproduced in whole or in part, committed to computer memory as a file or delivered to third parties without the prior authorization of the assembler of the system.

Munters reserves the right to effect modifications to the apparatus in accordance with technical and legal developments.

Index

| <i>chapter</i> | <i>page</i> |
|----------------|---|
| 1 | INTRODUCTION ————— 5 |
| 1.1 | Disclaimer ————— 5 |
| 1.2 | Introduction ————— 5 |
| 1.3 | Notes ————— 5 |
| 2 | USB RS-485 DRIVER GENERAL DESCRIPTION ————— 6 |
| 3 | USING THE USB RS-485 DRIVER ————— 7 |
| 3.1 | Installing the USB Driver ————— 7 |
| 3.2 | Driver Wiring ————— 8 |
| 4 | SPECIFICATIONS ————— 8 |
| 5 | WARRANTY ————— 9 |

1 Introduction

1.1 Disclaimer

Munters reserves the right to make alterations to specifications, quantities, dimensions etc. for production or other reasons, subsequent to publication. The information contained herein has been prepared by qualified experts within Munters. While we believe the information is accurate and complete, we make no warranty or representation for any particular purposes. The information is offered in good faith and with the understanding that any use of the units or accessories in breach of the directions and warnings in this document is at the sole discretion and risk of the user.

1.2 Introduction

Congratulations on your excellent choice of purchasing an USB Driver!

In order to realize the full benefit from this product it is important that it is installed, commissioned and operated correctly. Before installation or using the fan, this manual should be studied carefully. It is also recommended that it is kept safely for future reference. The manual is intended as a reference for installation, commissioning and day-to-day operation of the Munters Controllers.

1.3 Notes

Date of release: July 2010

Munters cannot guarantee to inform users about the changes or to distribute new manuals to them.

All rights reserved. No part of this manual may be reproduced in any manner whatsoever without the expressed written permission of Munters. The contents of this manual are subject to change without notice.

2 USB RS-485 Driver General Description

Munters' USB RS-485 Driver enables connecting the RLink or RLINK One Wireless Communication link to a PC. Data is transmitted via RS-485 cable to the driver, which then connected to a PC via a USB cable. The unit includes lightning protection. Figure 1 illustrates a sample network.

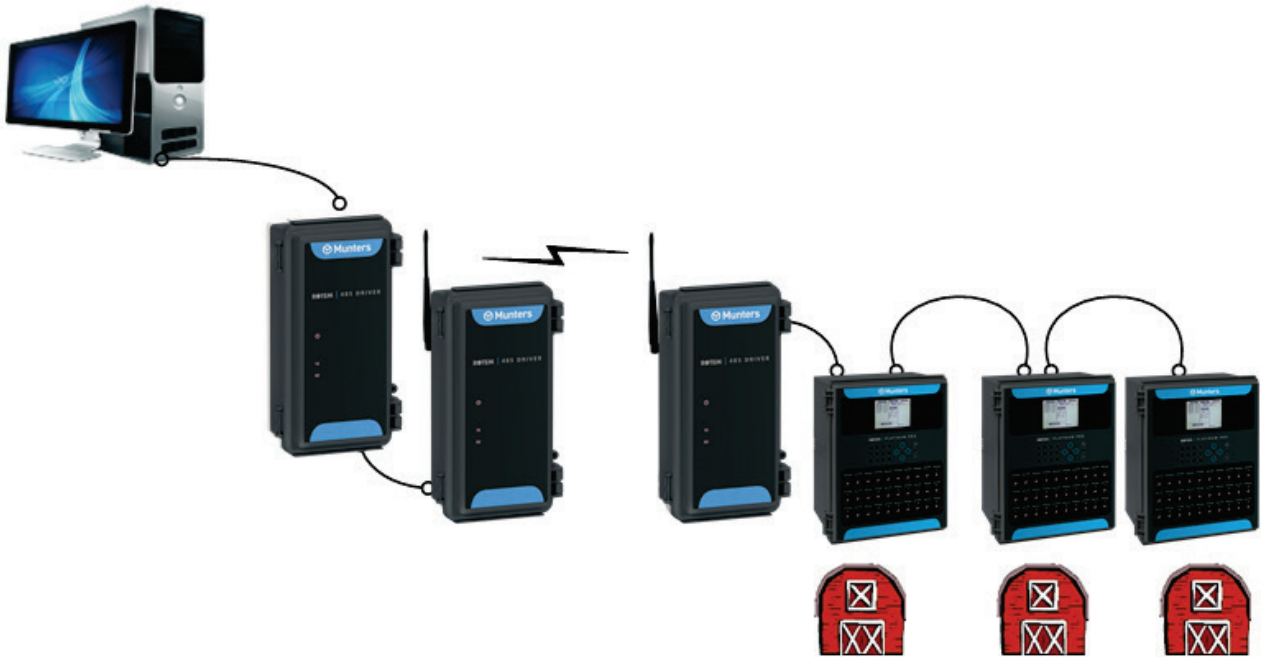

Figure 1: Sample Test Network

The USB RS-485 Driver LEDs (Figure 2) light up for activity notification. Use these LEDs as a diagnostic tool when performance issues arise. Table 1 details the LEDs' functions.

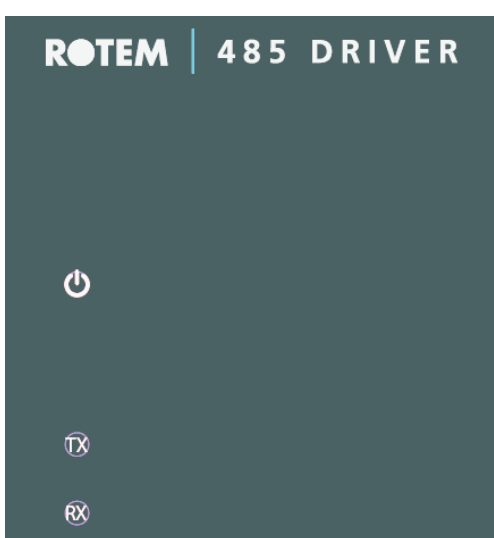

Table 1: Office Front Panel LED Description

| LED | Description |
|--------------------|---------------------------|
| Power | Power is on |
| LINE Transmit Data | Line is transmitting data |
| LINE Receive Data | Line is receiving data |

Figure 2: Front Panel LEDs

3 Using the USB RS-485 Driver

The following sections detail how to use the USBRS-485 Driver.

3.1 Installing the USB Driver

The following procedure details how to install R-USB Driver version 5.00. This driver must be installed before plugging in the USB cable between the host computer and the R-USB plug.

1. Ensure that the USB cable is disconnected from the RFT Office before installing the driver.

2. On the CD click  Setup
RotemUSB Driver
Rotem

3. Click .

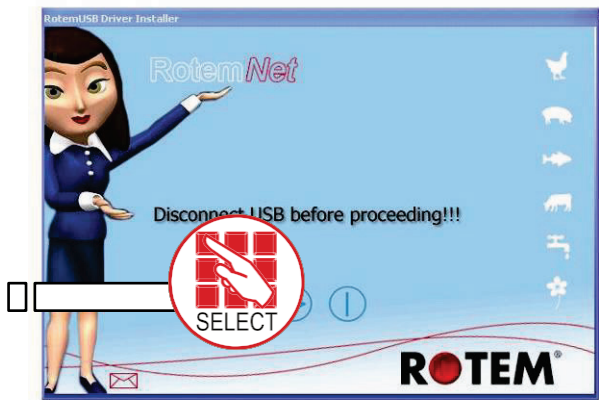

Figure 3: Install Driver Start Menu

4. Follow the instructions.
5. Restart the computer.
6. Connect the USB cable from the USB RS-485 Driver to the computer.

NOTE If older versions of the driver exist on the computer, the installation program must delete them. Click **Yes** if prompted.

3.2 Driver Wiring

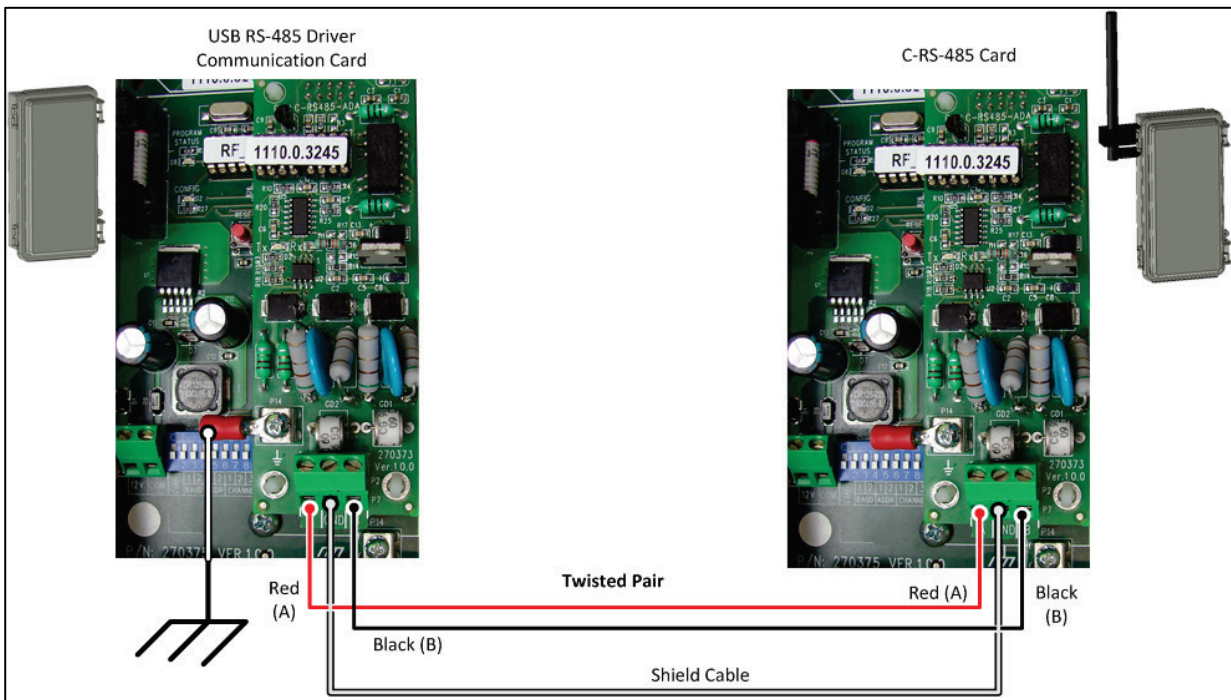

Figure 4: Wiring the Driver to an RLINK

CAUTION All dipswitches in the USB RS-485 Driver must remain off.

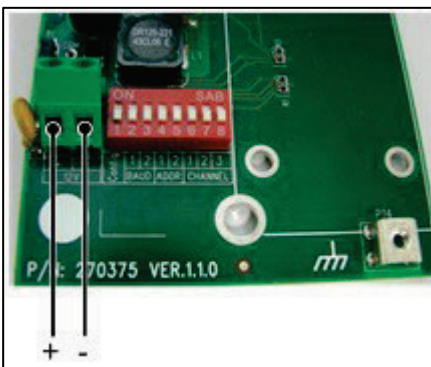

Figure 5: Power Wiring

4 Specifications

| | |
|--------------------|--|
| Power Requirements | 12 VDC \pm 10% (stabilized), 1 Amp (maximum) |
| PC Connectivity | USB Standard |
| RLINK Connectivity | RS-485 Standard |

5 Warranty

Warranty and technical assistance

Munters products are designed and built to provide reliable and satisfactory performance but cannot be guaranteed free of faults; although they are reliable products they can develop unforeseeable defects and the user must take this into account and arrange adequate emergency or alarm systems if failure to operate could cause damage to the articles for which the Munters plant was required: if this is not done, the user is fully responsible for the damage which they could suffer.

Munters extends this limited warranty to the first purchaser and guarantees its products to be free from defects originating in manufacture or materials for one year from the date of delivery, provided that suitable transport, storage, installation and maintenance terms are complied with. The warranty does not apply if the products have been repaired without express authorisation from Munters, or repaired in such a way that, in Munters' judgement, their performance and reliability have been impaired, or incorrectly installed, or subjected to improper use. The user accepts total responsibility for incorrect use of the products.

The warranty on products from outside suppliers fitted to USB Driver, (for example antennas, power supplies, cables, etc.) is limited to the conditions stated by the supplier: all claims must be made in writing within eight days of the discovery of the defect and within 12 months of the delivery of the defective product. Munters has thirty days from the date of receipt in which to take action, and has the right to examine the product at the customer's premises or at its own plant (carriage cost to be borne by the customer).

Munters at its sole discretion has the option of replacing or repairing, free of charge, products which it considers defective, and will arrange for their despatch back to the customer carriage paid. In the case of faulty parts of small commercial value which are widely available (such as bolts, etc.) for urgent despatch, where the cost of carriage would exceed the value of the parts, Munters may authorise the customer exclusively to purchase the replacement parts locally; Munters will reimburse the value of the product at its cost price.

Munters will not be liable for costs incurred in demounting the defective part, or the time required to travel to site and the associated travel costs. No agent, employee or dealer is authorised to give any further guarantees or to accept any other liability on Munters' behalf in connection with other Munters products, except in writing with the signature of one of the Company's Managers.

WARNING: In the interests of improving the quality of its products and services, Munters reserves the right at any time and without prior notice to alter the specifications in this manual.

The liability of the manufacturer Munters ceases in the event of:

- dismantling the safety devices;
- use of unauthorised materials;
- inadequate maintenance;
- use of non-original spare parts and accessories.

Barring specific contractual terms, the following are directly at the user's expense:

- preparing installation sites;
- providing an electricity supply (including the protective equipotential bonding (PE) conductor, in accordance with CEI EN 60204-1, paragraph 8.2), for correctly connecting the equipment to the mains electricity supply;
- providing ancillary services appropriate to the requirements of the plant on the basis of the information supplied with regard to installation;
- tools and consumables required for fitting and installation;
- lubricants necessary for commissioning and maintenance.

It is mandatory to purchase and use only original spare parts or those recommended by the manufacturer. Dismantling and assembly must be performed by qualified technicians and according to the manufacturer's instructions.

The use of non-original spare parts or incorrect assembly exonerates the manufacturer from all liability. Requests for technical assistance and spare parts can be made directly to the nearest Munters office. A full list of contact details can be found on the back page of this manual.

Munters Israel

18 HaSivim Street

Petach-Tikva 49517, Israel

Telephone: +972-3-920-6200

Fax: +972-3-924-9834

support@munters.co.il



www.munters.com

Australia Munters Pty Limited, Phone +61 2 8843 1594, **Brazil** Munters Brasil Industria e Comercio Ltda, Phone +55 41 3317 5050, **Canada** Munters Corporation Lansing, Phone +1 517 676 7070, **China** Munters Air Treatment Equipment (Beijing) Co. Ltd, Phone +86 10 80 481 121, **Denmark** Munters A/S, Phone +45 9862 3311, **India** Munters India, Phone +91 20 3052 2520, **Indonesia** Munters, Phone +62 818 739 235, **Israel** Munters Israel Phone +972-3-920-6200, **Italy** Munters Italy S.p.A., Chiusavecchia, Phone +39 0183 52 11, **Japan** Munters K.K., Phone +81 3 5970 0021, **Korea** Munters Korea Co. Ltd., Phone +82 2 761 8701, **Mexico** Munters Mexico, Phone +52 818 262 54 00, **Singapore** Munters Pte Ltd., Phone +65 744 6828, **South Africa and Sub-Sahara Countries** Munters (Pty) Ltd., Phone +27 11 997 2000, **Spain** Munters Spain S.A., Phone +34 91 640 09 02, **Sweden** Munters AB, Phone +46 8 626 63 00, **Thailand** Munters Co. Ltd., Phone +66 2 642 2670, **Turkey** Munters Form Endüstri Sistemleri A.Ş, Phone +90 322 231 1338, **USA** Munters Corporation Lansing, Phone +1 517 676 7070, **Vietnam** Munters Vietnam, Phone +84 8 3825 6838, **Export & Other countries** Munters Italy S.p.A., Chiusavecchia Phone +39 0183 52 11