

Munters Saturn FIVE Series

Air extraction fans

The Saturn FIVE series are feature rich, high-tech and completely modular fans, able to combine exceptional airflow with full energy efficiency. This means superior growth of livestock and yield, improved animal welfare and more sustainable business.

Modular

Fully flexible configuration to meet the needs of any farm

Sustainable

Designed to increase airflow while reducing operating costs, maintenance and energy consumption. The E-line version saves up to 50% on electricity costs

Reliable

Long service life and corrosion resistance features with Munters Protect, stainless steel and composite materials

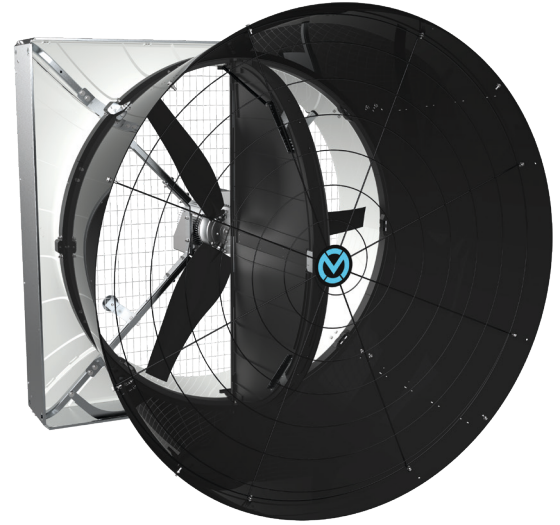

Saturn FIVE Direct drive 3 blades

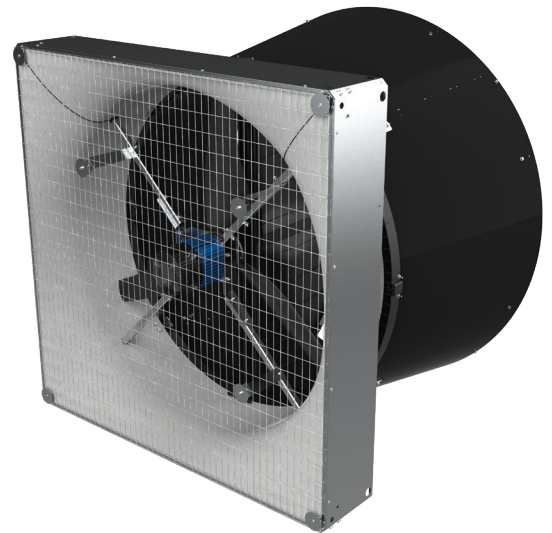

Saturn FIVE E-line 3 blades

Designed to meet every farmer's needs, for any livestock or greenhouse application, in any climate zone. The modular configuration addresses specific demands, including corrosion resistance in harsh environments and various installation options.

An innovative butterfly damper guarantees animal welfare and reduces energy waste. This patent-pending plastic damper reduces air draft by closing tightly when the fan is off. Without the actuator, the damper opens and remains open even at high pressure operations, avoiding performance drops.

For maximum energy savings, the E-line version reduces power consumption by up to 50% compared to the same fan with AC motor, all while enabling speed regulation.

Designed to require zero maintenance while delivering consistently high performance over a long service life.

As the market leader in ventilation solutions for more than 60 years, Munters guarantees quality and is ISO 9001 certified.

Darkening solution, available upon request

Munters LFD light filter

Light control plays a critical role in modern poultry farming. Especially in breeding and rearing farms, correct light control is essential to achieving ambitious production targets.

- Light reduction factor 2.000.000:1
- Installation directly on Munters Saturn FIVE¹

¹LFD cannot be used with Belt 1.5

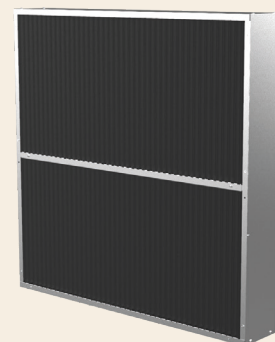

Munters Saturn FIVE Series

Suggested configurations by application

Application		Motor			Propeller		Housing	Max static pressure
		Type	Drive	Nominal power	Blades	Material ¹	Material ¹	
Poultry	Broiler (floor)	AC	Direct	2.0 hp	3	Composite	MP	75 Pa
		AC	Belt	1.5 hp	3	MP	MP	75 Pa
	Layer (light control)	AC	Direct	2.0 hp	5	Composite	MP	150 Pa
		AC	Belt	2.0 hp	6	MP	MP	100 Pa
	Mega houses (broiler, layer)	AC	Direct	2.0 hp	3 5	Composite	MP	75 Pa 150 Pa
		AC	Belt	2.0 hp	6	MP	MP	100 Pa
Swine	Mega houses	AC	Direct	2.0 hp	3 5	Composite	MP	75 Pa 150 Pa
		AC	Belt	1.5 hp	3	SS	SS/MP	75 Pa
Greenhouse		AC	Belt	1.5 hp	3	MP	MP	75 Pa
All application	E-line	EC	Direct	3.0 hp	3 5	Composite	MP	75 Pa 150 Pa

¹MP: Munters Protect, SS: Stainless Steel

Installation options

Wall mount

Installation directly on the external wall, suitable for sandwich panel or wooden wall.

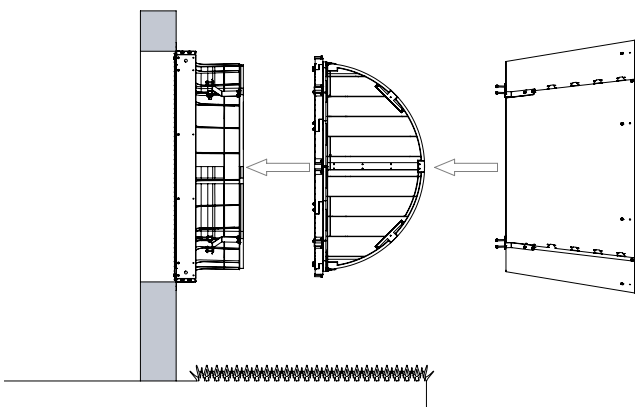
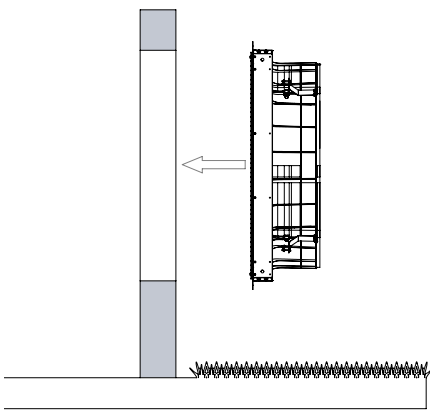

Through wall mount

Installation from inside the house, suitable for brick or concrete wall with metal reinforcement.

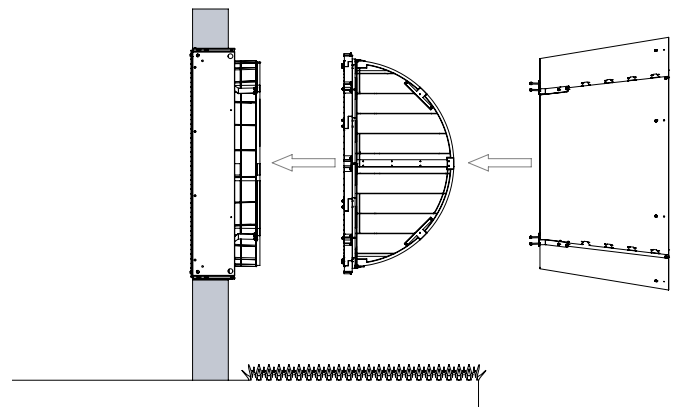
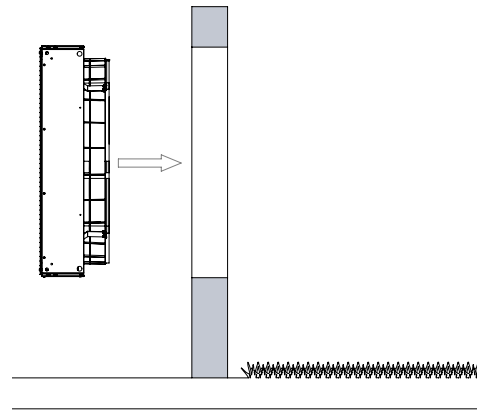

Munters Saturn FIVE Series

AC motor

Dimensions

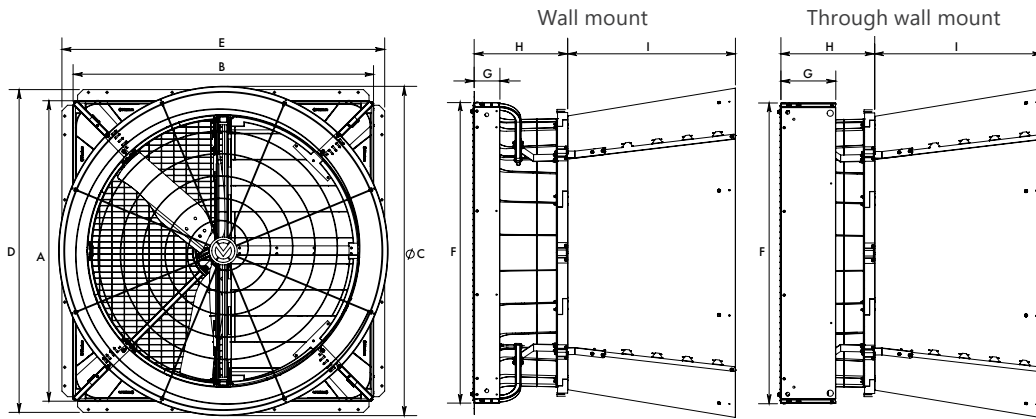

	A	B	C	D	E	F	G	H	I
Wall mount	1615 mm	1615 mm	1770 mm	1735 mm	1735 mm	1615 mm	139 mm	504 mm	900 mm
Through wall mount	1615 mm	1615 mm	1770 mm	-	-	1615 mm	295 mm	504 mm	900 mm

Technical specifications

		Belt 1.5	Belt 2.0	Direct 2.0
Nominal power	hp	1.5	2.0	2.0
Propeller diameter	mm [inch]	1400 [55]	1400 [55]	1400 [55]
Number of blades/material		3/Munters Protect	6/Munters Protect	3/Composite 5/Composite
Motor/drive type		AC/Belt	AC/Belt	AC/Direct
Weight of fully equipped fan	kg	100	120	115 116
Max power consumption/max current ¹	W/A	1850/3.3	2485/4.3	2220/4.4 2390/4.6
Protective class of electric motor		IP55	IP55	IP55
Noise level ²	Db(a)	75.6	76.9	76.9 78.1

¹50 Hz 400 V specification, 60 Hz available upon request (not available with Direct drive 5 blades), ²Noise measured according to ISO 3744

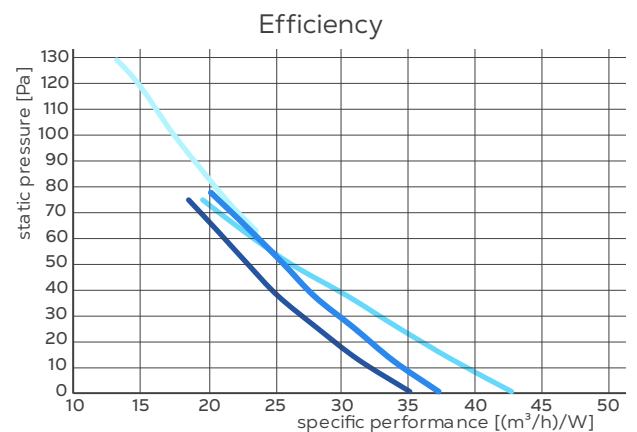
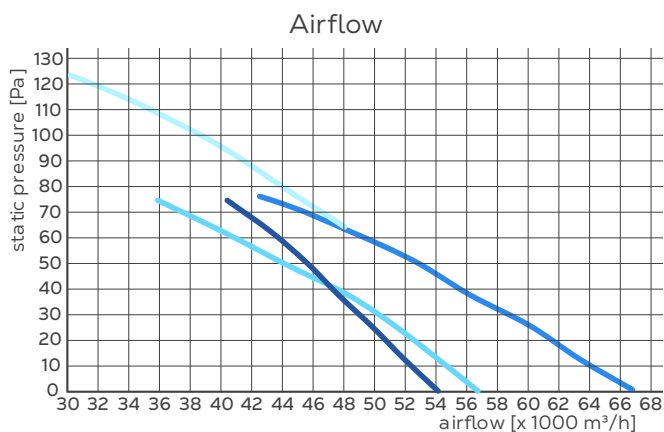

Belt 1.5		Belt 2.0		Direct 2.0			
Motor	BESS Lab	Motor	BESS Lab	Motor	BESS Lab	Motor	BESS Lab
— IE3 1.5 hp	#22429	— IE3 2.0 hp	#22106	— IE3 2.0 hp, 3 blades	#23273	— IE3 2.0 hp, 5 blades	#23274

Load capacity

	Belt 1.5		Belt 2.0		Direct 2.0	
	Unassembled	Assembled ¹	Unassembled	Assembled ¹	Unassembled	Assembled ¹
40' HC container	102	36	86	36	90	30
13.6 m truck	-	42	-	42	-	35

¹Wall mount not available

Munters Saturn FIVE Series

E-line

Dimensions

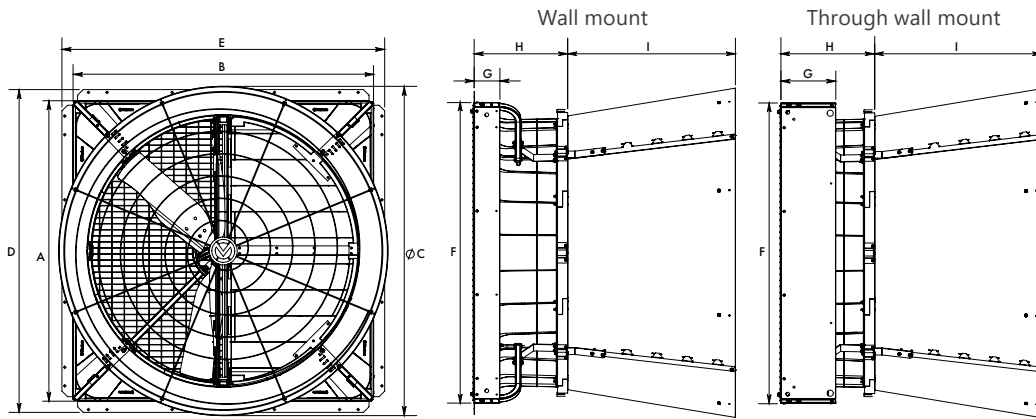

	A	B	C	D	E	F	G	H	I
Wall mount	1615 mm	1615 mm	1770 mm	1735 mm	1735 mm	1615 mm	139 mm	504 mm	900 mm
Through wall mount	1615 mm	1615 mm	1770 mm	-	-	1615 mm	295 mm	504 mm	900 mm

Technical specifications

			E-line	
Nominal power	hp	3.0		
Propeller diameter	mm [inch]	1400 [55]		
Nominal propeller speed	rpm	730		
Motor/drive type	EC/Direct			
Number of blades/material		3/Composite	5/Composite	
Weight of fully equipped fan	kg	100	101	
Max power consumption/max current ¹	W/A	2400/4.5	2700/5.1	
Protective class of electric motor	IP66			
Noise level ²	Db(a)	79.6	78.1	

¹50 Hz 400 V specification, 60 Hz available upon request, ²Noise measured according to ISO 3744

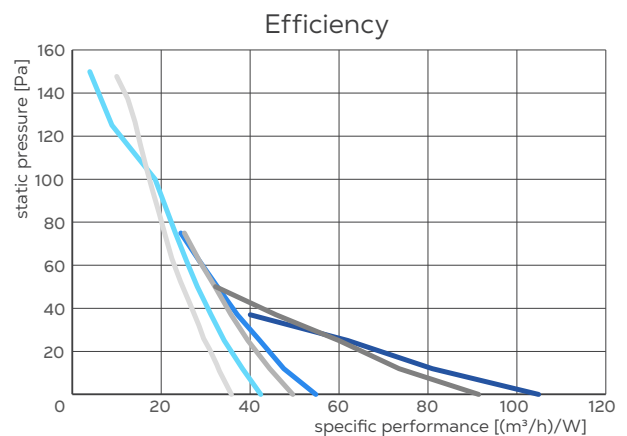
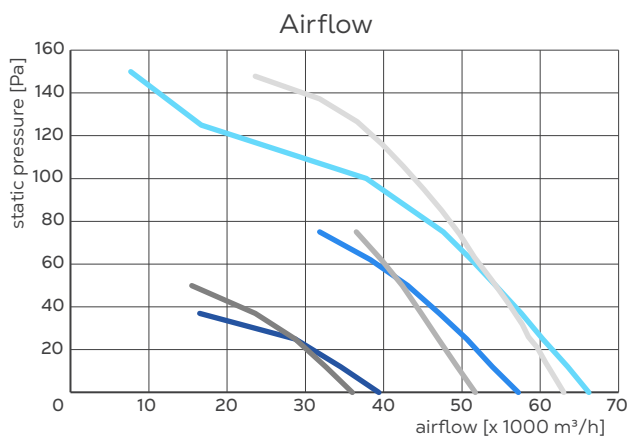

3 bl.: — 730 rpm, — 630 rpm, — 430 rpm; 5 bl.: — 730 rpm, — 630 rpm, — 430 rpm. Airflow and efficiency data according to BESS Lab test #23258

Load capacity

	E-line	
	Unassembled	Assembled ¹
40' HC container	90	36
13.6 m truck	-	42

¹Wall mount not available

Find your nearest Munters office at www.munters.com

Munters reserves the right to make alterations to specifications, quantities, etc., for production or other reasons, subsequent to publication. © Munters AB, 2024