

Manual for use and maintenance

RSLC Load
Cell and
Junction Box

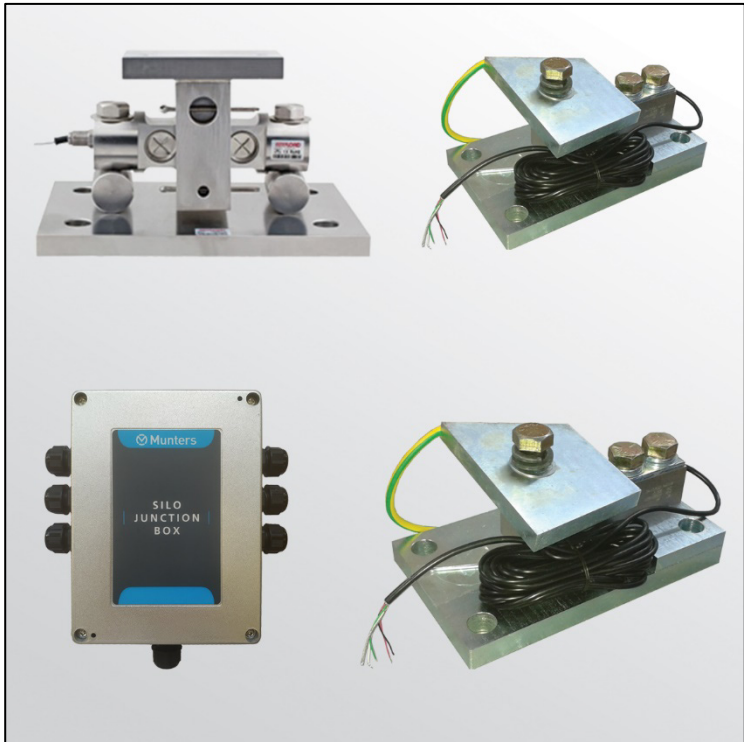

RSLC and RJB-6

Silo Weighing Scale/Junction Box

RSLC Load Cell and RJB-6 Junction Box

Manual for use and maintenance

Revision: N.1.4 of 09/2022

Product Software: N/A

This manual for use and maintenance is an integral part of the apparatus together with the attached technical documentation.

This document is destined for the user of the apparatus: it may not be reproduced in whole or in part, committed to computer memory as a file or delivered to third parties without the prior authorization of the assembler of the system.

Munters reserves the right to effect modifications to the apparatus in accordance with technical and legal developments.

Index

<i>Chapter</i>		<i>page</i>
1	INTRODUCTION -----	4
	1.1 Disclaimer-----	4
	1.2 Introduction-----	4
	1.3 Notes -----	4
2	RJB-6 INSTALLATION -----	5
3	RSLC INSTALLATION -----	8
	3.1 RSLC-4 -----	9
	3.1.1 RSLC-4 Installation.....	9
	3.1.2 RSLC-4 Specifications.....	9
	3.2 RSLC-10 -----	11
	3.2.1 RSLC-10 Installation	11
	3.2.2 RSLC-10 Specifications.....	11
	3.3 RSLC-25 -----	13
	3.3.1 RSLC-25 Installation	13
	3.3.2 RSLC-25 Specifications.....	13
	3.4 Environmental Protection -----	14
4	TROUBLESHOOTING -----	15
	4.1 Known Problems -----	15
	4.2 Load Cell Test Procedure -----	16
5	WARRANTY -----	17

1 Introduction

1.1 Disclaimer

Munters reserves the right to make alterations to specifications, quantities, dimensions etc. for production or other reasons, subsequent to publication. The information contained herein has been prepared by qualified experts within Munters. While we believe the information is accurate and complete, we make no warranty or representation for any particular purposes. The information is offered in good faith and with the understanding that any use of the units or accessories in breach of the directions and warnings in this document is at the sole discretion and risk of the user.

1.2 Introduction

Congratulations on your excellent choice of purchasing an RSLC Load Cell and RJB-6 Junction Box! In order to realize the full benefit from this product it is important that it is installed, commissioned and operated correctly. Before installation or using the units, this manual should be studied carefully. It is also recommended that it is kept safely for future reference. The manual is intended as a reference for installation, commissioning and day-to-day operation of the Munters equipment.

1.3 Notes

Date of release: July 2010

Munters cannot guarantee to inform users about the changes or to distribute new manuals to them.

NOTE All rights reserved. No part of this manual may be reproduced in any manner whatsoever without the expressed written permission of Munters. The contents of this manual are subject to change without notice.

2 RJB-6 Installation

Munters RJB-6 enables connecting up to eight load cells to a single controller. This section details how to mount and wire the RJB-6.

1. Remove the four cover screws to open the unit.



Figure 1: Opening the RJB-6 Cover

2. Using a drill and the supplied screws, attach the RJB-6 to a silo leg.

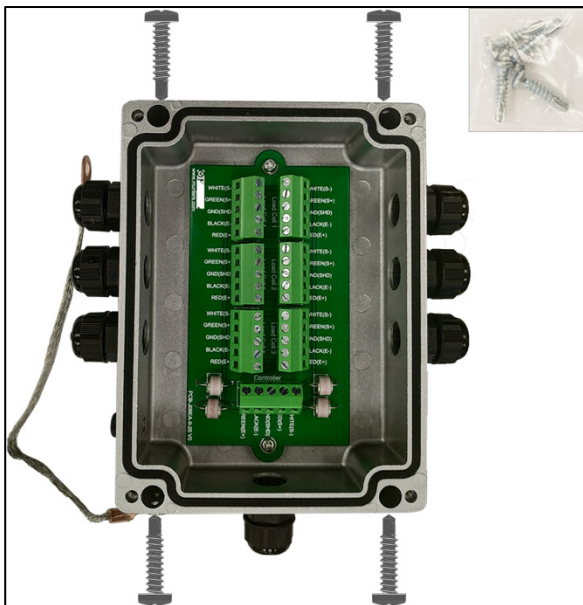

Figure 2: RJB-6 Mounting

3. Close the unit.
4. Attach the grounding cable to a silo leg.



Figure 3: Grounding the RJB

5. Wire the RJB-6 units to the RSLC units. Each RSLC (load cell) has four-wire shielded cables plus a shield cable(ground). Connect each load cell to the RJB-6 according to the colors inscribed on the RJB PCB board (Figure 4).

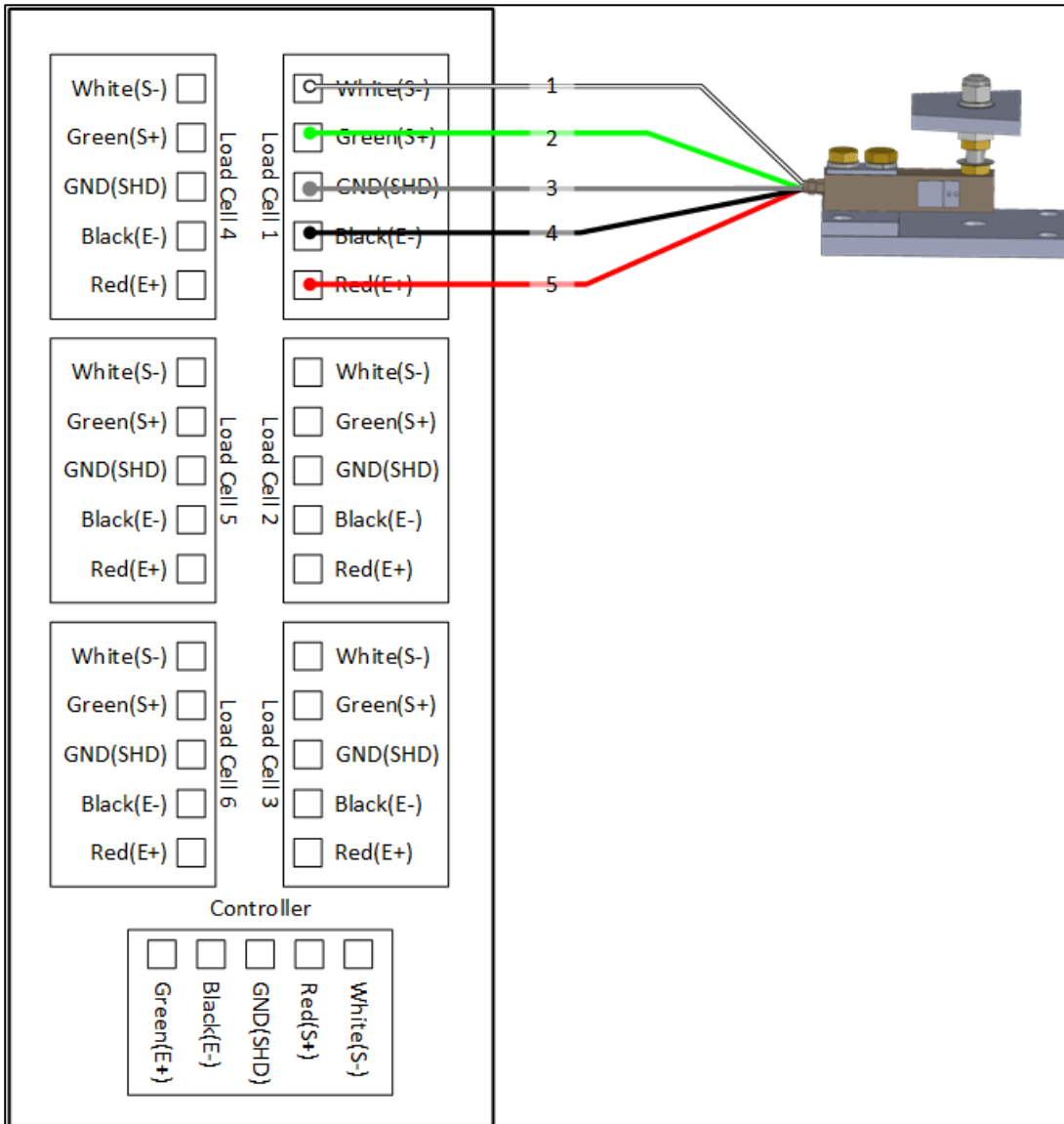

Figure 4: RJB - RSLC Wiring

- Cable: Board
 - White - White
 - Red - Red
 - Black - Black
 - Green - Green
 - Connect the shield wire to the GND(SHD) port.

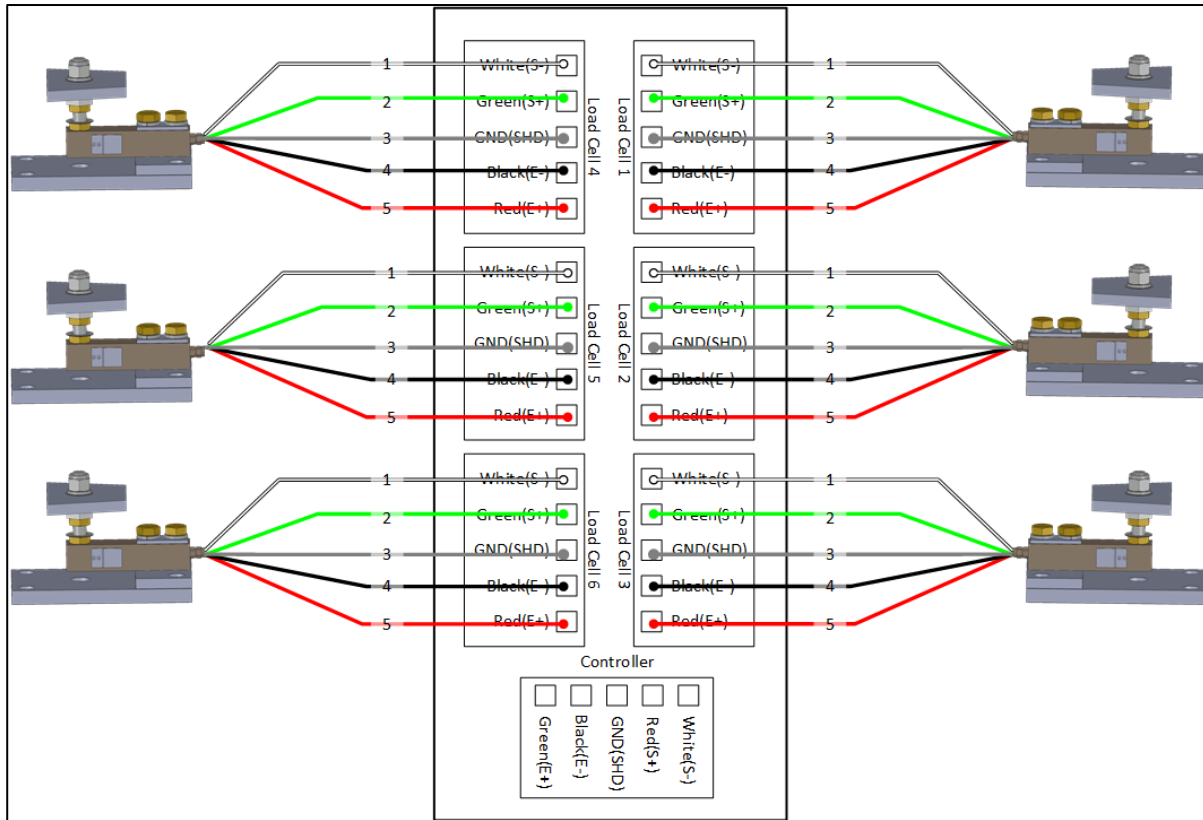

Figure 5: RJB – Six RSLCs Wiring

Figure 5 key	
1	If there are eight load cells, add the two remaining cells along with load cells 1 and 2

6. Connect the relevant controller cables to the "Controller" terminal block within the RJB junction box. The connection colors of this cable are direct connection.

NOTE Refer to the specific controller manual for details on wiring the RJB-6 to the controller.

- Cable: Board
 - White - White
 - Red - Red
 - Black - Black
 - Green - Green

3 RSLC Installation

The following sections detail how to install the:

- RSLC-4 supports up to 4,000 pounds (per leg)
- RSLC-10 supports up to 10,000 pounds (per leg)
- RSLC-25 supports up to 25,000 pounds (per leg)

Place load cells under each silo leg.



Figure 6: Silo Legs and Load Cells

The RSLC units comes with a grounding cable that, if required, can be run from one silo leg to a grounding rod.

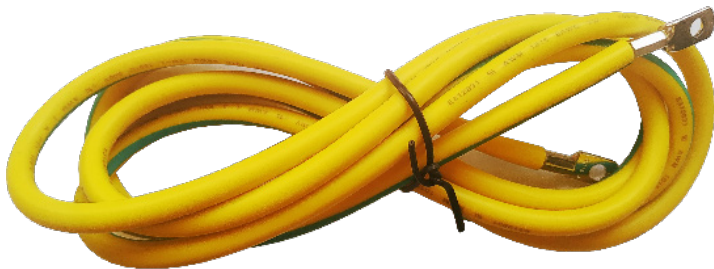

Figure 7: Grounding cable

3.1 RSLC-4



Figure 8: RSLC-4 Unit

- RSLC-4 Installation
- RSLC-4 Specifications

3.1.1 RSLC-4 Installation

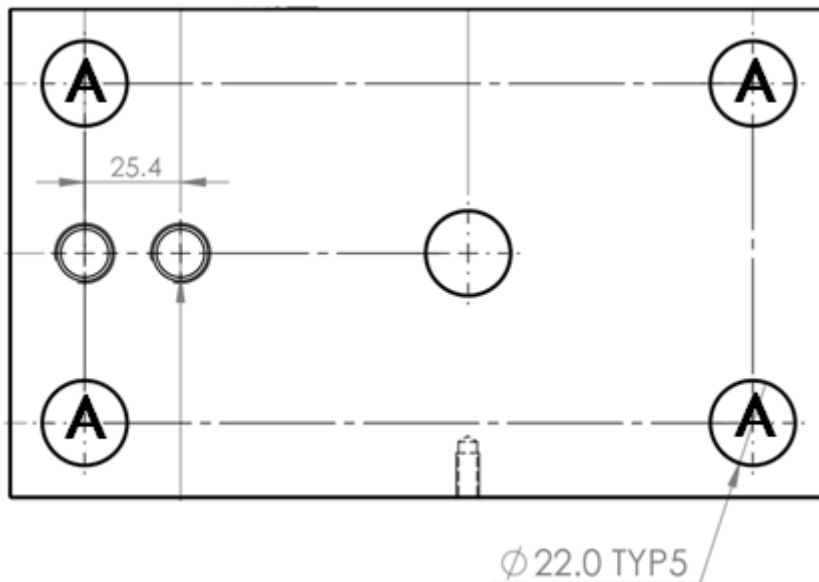

Figure 9: RSLC-4 Plate Dimensions

1. Figure 9 illustrates the RSLC-4 plate. Drill four holes into the concrete base as indicated (A).
2. Wire the Load Cells to the RJB-6.

3.1.2 RSLC-4 Specifications

Table 1: RSLC-4 Specifications

Parameter	Value
Full Scale Output	3.0 mV/V \pm 0.25%
Zero Balance	\pm 0.02 mV/V
Input Resistance	400 Ω \pm 20 for kg; 350 Ω \pm 7 for lb.
Output Resistance	350 Ω \pm 3

Parameter	Value
Element Material	Alloy Steel, Nickel Plated
Recommended Excitation	10V (15V Maximum)
Insulation Resistance	>2 [50V DC] GΩ
Compensated Temperature Range	-10°C to 50°C / 14°F to 122°F
Safe Overload	150% of full scale
Breaking Overload	300% of full scale
Seal Type / IP Rating	Cap. ≤300kg/500lb: Environmentally Sealed / IP66 Cap. ≥500kg/1Klb: Environmentally Sealed / IP67

Figure 10 and Table 2 detail the RSLC-4 Load Cell dimensions.

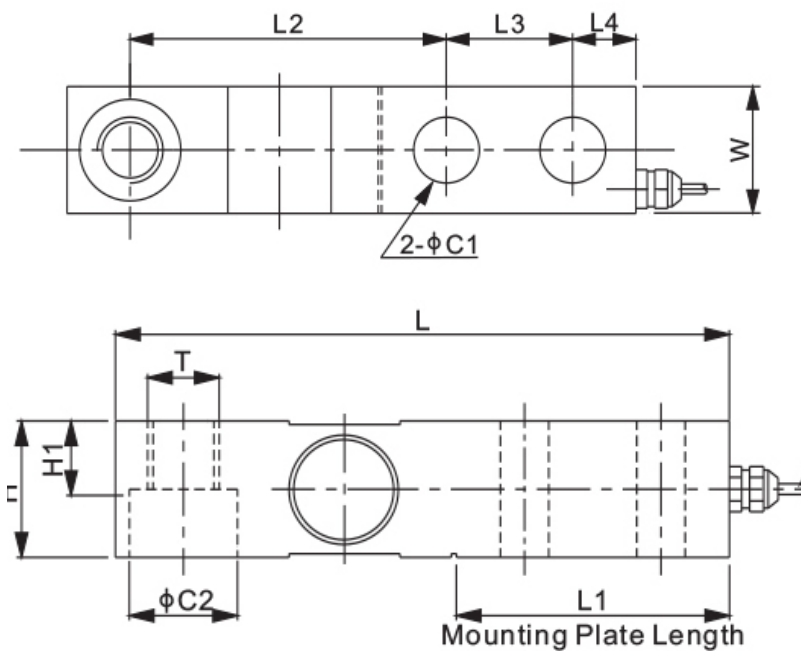

Figure 10: RSLC-4 Load Cell Dimensions

Table 2: RSLC-4 Load Cell Dimensions Details

Letter	C1	C2	H	H1	L	L1	L2	L3	L4	W
Dimensions (in)	0.53	0.81	1.25	0.60	5.12	2.25	3.00	1.00	0.62	1.25
Dimensions (mm)	13.5	20/6	31.8	15.2	130	57.2	76.2	25.4	15.8	31.8

3.2 RSLC-10



Figure 11: RSLC-10 Unit

- RSLC-10 Installation
- RSLC-10 Specifications

3.2.1 RSLC-10 Installation

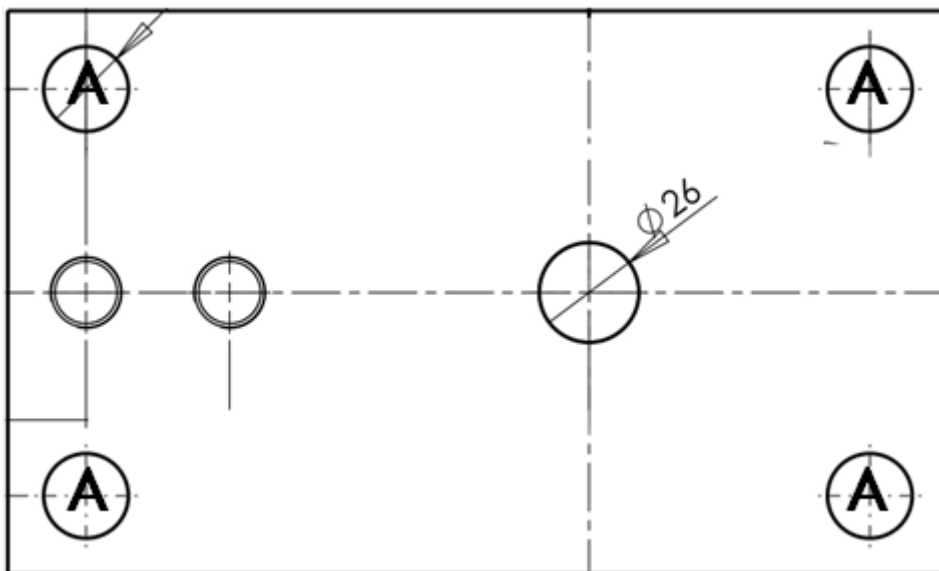

Figure 12: RSLC-10 Plate Dimensions

1. Figure 12 illustrates the RSLC-10 plate. Drill four holes into the concrete base as indicated (A).
2. Wire the Load Cells to the RJB-6.

3.2.2 RSLC-10 Specifications

Table 3: RSLC-10 Specifications

Parameter	Value
Full Scale Output	3.0 mV/V \pm 0.25%
Zero Balance	\pm 0.02 mV/V
Input Resistance	400 Ω \pm 20 for kg; 350 Ω \pm 7 for lb.

Parameter	Value
Output Resistance	350 $\Omega \pm 3$
Element Material	Alloy Steel, Nickel Plated
Recommended Excitation	10V (15V Maximum)
Insulation Resistance	>2 [50V DC] G Ω
Compensated Temperature Range	-10°C to 50°C / 14°F to 122°F
Safe Overload	150% of full scale
Breaking Overload	300% of full scale
Seal Type / IP Rating	Cap. \leq 300kg/500lb: Environmentally Sealed / IP66 Cap. \geq 500kg/1Klb: Environmentally Sealed / IP67

Figure 13 and Table 4 detail the RSLC-10 Load Cell dimensions.

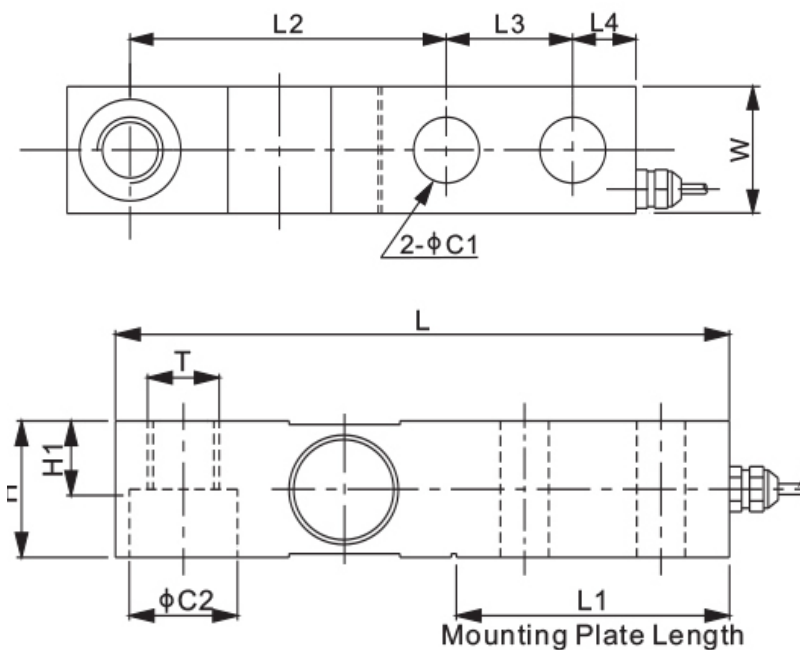

Figure 13: RSLC-10 Load Cell Dimensions

Table 4: RSLC-10 Load Cell Dimensions Details

Letter	C1	C2	H	H1	L	L1	L2	L3	L4	W
Dimensions (in)	0.78	1.19	1.50	0.75	6.75	3.00	3.75	1.50	0.75	1.50
Dimensions (mm)	19.8	30.2	38.1	19.1	171.5	76.2	95.3	38.1	19.1	38.1

3.3 RSLC-25



Figure 14: RSLC-25 Unit

- RSLC-25 Installation
- RSLC-25 Specifications

3.3.1 RSLC-25 Installation

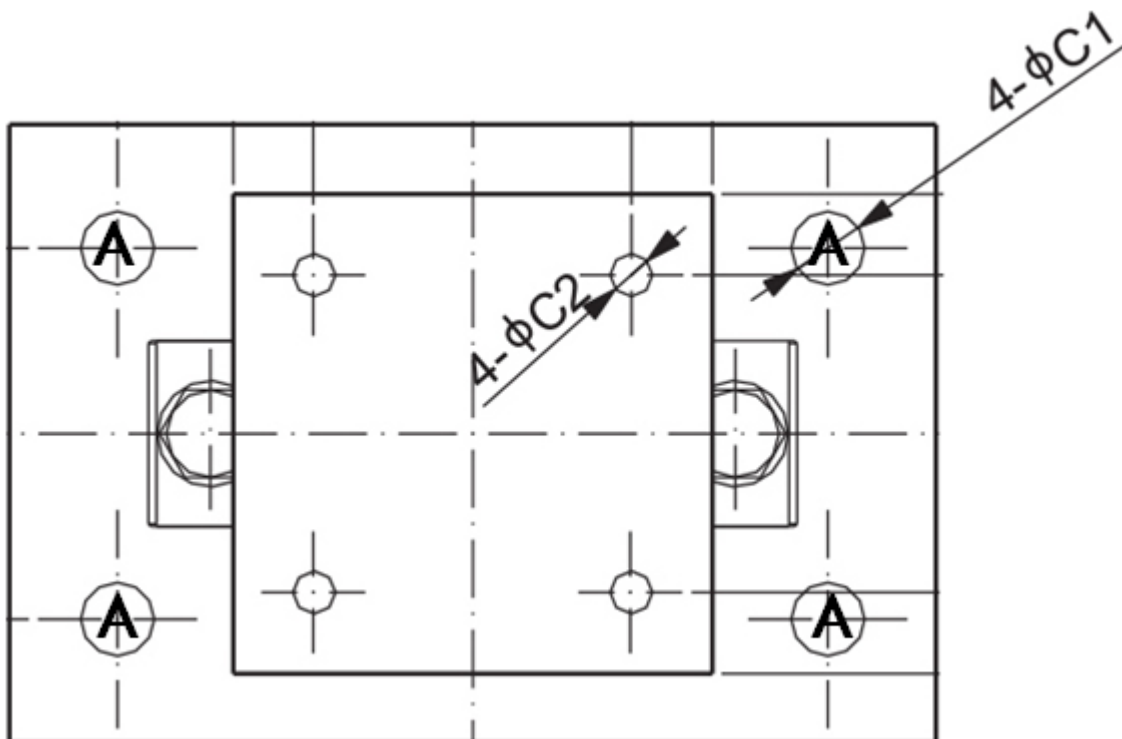

Figure 15: RSLC-25 Plate Dimensions

1. Figure 15 illustrates the RSLC-25 plate. Drill four holes into the concrete base as indicated (A).
2. Wire the Load Cells to the RJB-6.

3.3.2 RSLC-25 Specifications

Parameter	Value
Full Scale Output	3.0 mV/V \pm 0.25%
Zero Balance	\pm 0.02 mV/V

Parameter	Value
Input Resistance	700Ω±10
Output Resistance	700Ω±5
Element Material	Alloy Steel, Nickel Plated
Recommended Excitation	10V (15V Maximum)
Insulation Resistance	>2 [50V DC] GΩ
Compensated Temperature Range	-10oC to 50oC / 14oF to 122oF
Safe Overload	150% of full scale
Breaking Overload	300% of full scale
Seal Type / IP Rating	Environmentally Sealed / IP67

Figure 16 and Table 5 detail the RSLC-25 Load Cell dimensions.

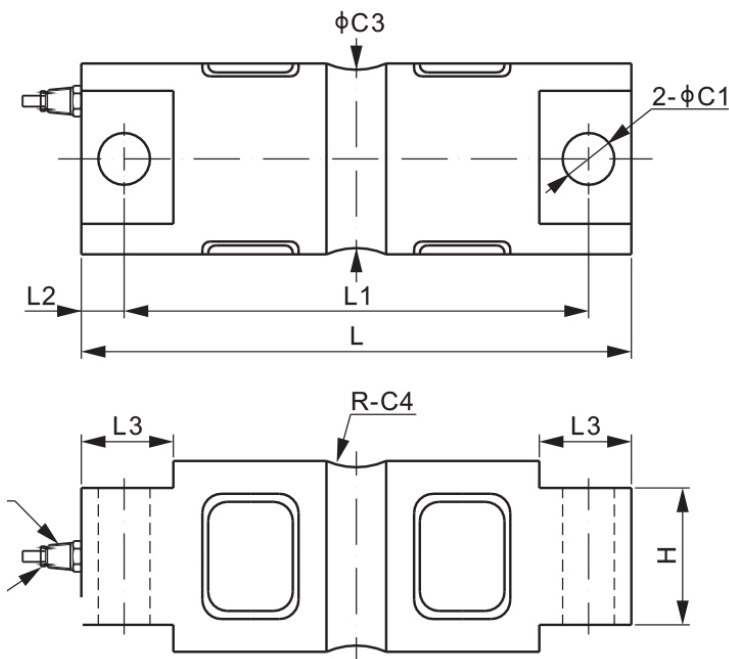

Figure 16: RSLC-25 Load Cell Dimensions

Table 5: RSLC-25 Load Cell Dimensions Details

Letter	C1	C2	C3	C4	H	L	L1	L2	L3
Dimensions (inches)	0.66	1.85	1.48	0.50	1.12	8.12	6.87	0.62	1.44
Dimensions (mm)	16.7	49.5	37.6	12.7	28.4	206.2	174.6	15.8	36.6

3.4 Environmental Protection

	<p>Recycle raw materials instead of disposing as waste. The controller, accessories and packaging should be sorted for environmental-friendly recycling. The plastic components are labeled for categorized recycling.</p>
--	--

4 Troubleshooting

4.1 Known Problems

#	Problem Description	Troubleshooting
1	Installation and filling feed has been done but silo stops weighing.	<p>If the display of Silo A does not show A/D '65536' counts on 16 bits, lower the offset (see Load Cell Test Procedure) until this number changes. After receiving numbers shown on the screen, reducing the numbers should be done according to: $[65536 - (\text{number of Kg missing in the silo} * \text{Silo 1 Scale Factor})]$</p> <p>After new installation is done and the Silo is empty, the A/D reading should be around 1000 counts (near zero), use the offset feature to get it.</p> <p>If the display shows '0', increase it by using offset feature.</p>
2	The controller display shows "disconnected" (or Error) and the test menu shows 65,536 or 0 rather than a voltage measurement that is required to identify the error.	<p>Check if RJB received voltage from controller (green and black wires from controller should be approximately 10 DCV). If not received, check wire connections on the controller's side.</p> <p>If 10 DCV is received, load cells must be checked (see Load Cell Test Procedure, page 16 for further explanation): Take White and Green wires from each load cell and check their voltage using a digital multi meter (the amount is not important but it must be identical throughout load cells with a difference of up to 2 mV). If difference is more than 2mV there is a problem with one of the load cells. The range of voltage should be between 0 to 20 mV depending on Silo load.</p> <p>In some cases, when the prior test is not effective and voltage between Black (common) wire and White, and between Black and Green, wires must be checked (amount of voltage must be between 4-4.5V and identical throughout load cells).</p>

4.2 Load Cell Test Procedure

To perform a load-cell test procedure, disconnect the load cell from any load and test following points:

1. Disconnect the white and green wires from each load cell at the Junction Box.
2. Measure the voltage between the green and the white wires with a DC voltmeter, at each load cell.
 - The voltage should be 0 to 30mV proportional to the silo weight.
 - The voltage difference between load cells should not exceed 3mV.

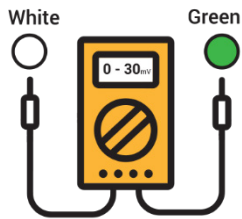

5 Warranty

Warranty and technical assistance

Munters products are designed and built to provide reliable and satisfactory performance but cannot be guaranteed free of faults; although they are reliable products they can develop unforeseeable defects and the user must take this into account and arrange adequate emergency or alarm systems if failure to operate could cause damage to the articles for which the Munters plant was required: if this is not done, the user is fully responsible for the damage which they could suffer.

Munters extends this limited warranty to the first purchaser and guarantees its products to be free from defects originating in manufacture or materials for one year from the date of delivery, provided that suitable transport, storage, installation and maintenance terms are complied with. The warranty does not apply if the products have been repaired without express authorisation from Munters, or repaired in such a way that, in Munters' judgement, their performance and reliability have been impaired, or incorrectly installed, or subjected to improper use. The user accepts total responsibility for incorrect use of the products.

The warranty on products from outside suppliers fitted to RSLC/RJB, (for example cables, scales, power supplies, etc.) is limited to the conditions stated by the supplier: all claims must be made in writing within eight days of the discovery of the defect and within 12 months of the delivery of the defective product. Munters has thirty days from the date of receipt in which to take action, and has the right to examine the product at the customer's premises or at its own plant (carriage cost to be borne by the customer).

Munters at its sole discretion has the option of replacing or repairing, free of charge, products which it considers defective, and will arrange for their despatch back to the customer carriage paid. In the case of faulty parts of small commercial value which are widely available (such as bolts, etc.) for urgent despatch, where the cost of carriage would exceed the value of the parts, Munters may authorise the customer exclusively to purchase the replacement parts locally; Munters will reimburse the value of the product at its cost price.

Munters will not be liable for costs incurred in demounting the defective part, or the time required to travel to site and the associated travel costs. No agent, employee or dealer is authorised to give any further guarantees or to accept any other liability on Munters' behalf in connection with other Munters products, except in writing with the signature of one of the Company's Managers.

WARNING: *In the interests of improving the quality of its products and services, Munters reserves the right at any time and without prior notice to alter the specifications in this manual.*

The liability of the manufacturer Munters ceases in the event of:

- dismantling the safety devices;
- use of unauthorised materials;
- inadequate maintenance;
- use of non-original spare parts and accessories.

Barring specific contractual terms, the following are directly at the user's expense:

- preparing installation sites;
- providing an electricity supply (including the protective equipotential bonding (PE) conductor, in accordance with CEI EN 60204-1, paragraph 8.2), for correctly connecting the equipment to the mains electricity supply;
- providing ancillary services appropriate to the requirements of the plant on the basis of the information supplied with regard to installation;
- tools and consumables required for fitting and installation;
- lubricants necessary for commissioning and maintenance.

It is mandatory to purchase and use only original spare parts or those recommended by the manufacturer.

Dismantling and assembly must be performed by qualified technicians and according to the manufacturer's instructions.

The use of non-original spare parts or incorrect assembly exonerates the manufacturer from all liability.

Requests for technical assistance and spare parts can be made directly to the [nearest Munters office](#).

