

# Manual for use and maintenance

Repeater  
Unit



## Repeater

# Repeater

## Manual for use and maintenance

Revision 1.0 of 03.2019

This manual for use and maintenance is an integral part of the apparatus together with the attached technical documentation.

This document is destined for the user of the apparatus: it may not be reproduced in whole or in part, committed to computer memory as a file or delivered to third parties without the prior authorization of the assembler of the system.

Munters reserves the right to effect modifications to the apparatus in accordance with technical and legal developments.

# Index

| <i>Chapter</i> |                            | <i>page</i> |
|----------------|----------------------------|-------------|
| <b>1</b>       | <b>INTRODUCTION</b> -----  | <b>5</b>    |
| 1.1            | Disclaimer.....            | 5           |
| 1.2            | Introduction.....          | 5           |
| 1.3            | Notes .....                | 5           |
| <b>2</b>       | <b>REPEATER UNIT</b> ----- | <b>6</b>    |
| 2.1            | Block Diagrams.....        | 7           |
| 2.2            | Wiring Diagrams.....       | 8           |
| <b>3</b>       | <b>WARRANTY</b> -----      | <b>12</b>   |

# 1 Introduction

## 1.1 Disclaimer

Munters reserves the right to make alterations to specifications, quantities, dimensions etc. for production or other reasons, subsequent to publication. The information contained herein has been prepared by qualified experts within Munters. While we believe the information is accurate and complete, we make no warranty or representation for any particular purposes. The information is offered in good faith and with the understanding that any use of the units or accessories in breach of the directions and warnings in this document is at the sole discretion and risk of the user.

## 1.2 Introduction

Congratulations on your excellent choice of purchasing a Repeater!

In order to realize the full benefit from this product it is important that it is installed, commissioned and operated correctly. Before installation or using the fan, this manual should be studied carefully. It is also recommended that it is kept safely for future reference. The manual is intended as a reference for installation, commissioning and day-to-day operation of the Munters Controllers.

## 1.3 Notes

Date of release: February 2009

Munters cannot guarantee to inform users about the changes or to distribute new manuals to them.

All rights reserved. No part of this manual may be reproduced in any manner whatsoever without the expressed written permission of Munters. The contents of this manual are subject to change without notice.

## 2 Repeater unit

Munters' Repeater enables:

- extending cable length between a Comm-Box, PC. MUX and controllers
- setting up your controllers in a star configuration
- increasing the number of controllers
- increasing the baud rate between the Comm-Box, PC. MUX and controllers
  
- If your current setup is: 16 controllers, 1000 meters and a baud rate of 9600, installing the **RS-485 Repeater** enables:
  - increasing the number of controllers to 32
  - or increasing the cable length to 2000 meters
  - or increasing the baud rate to 19200
  
- If your current setup is 16 controllers, 500 meters and a baud rate of 4800, installing the **RS-232 Repeater** enables:
  - increasing the number of controllers to 32
  - or increasing the cable length to 1000 meters
  - or increasing the baud rate to 9600

*NOTE: The RS-485 Repeater supports RS-485 transmission only; the RS-232 Repeater supports RS-232 transmission only.*

## 2.1 Block Diagrams

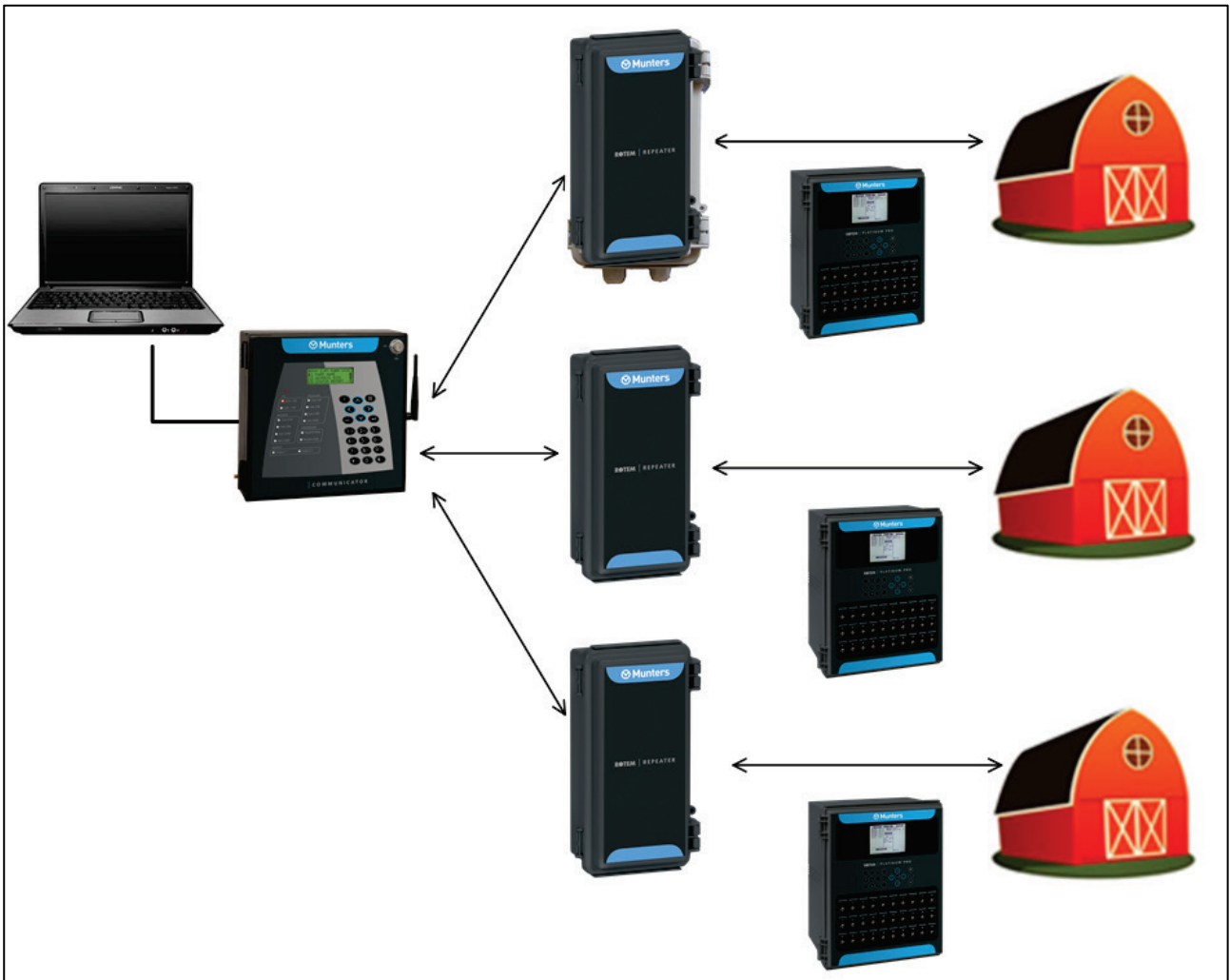

Figure 1: Star Configuration

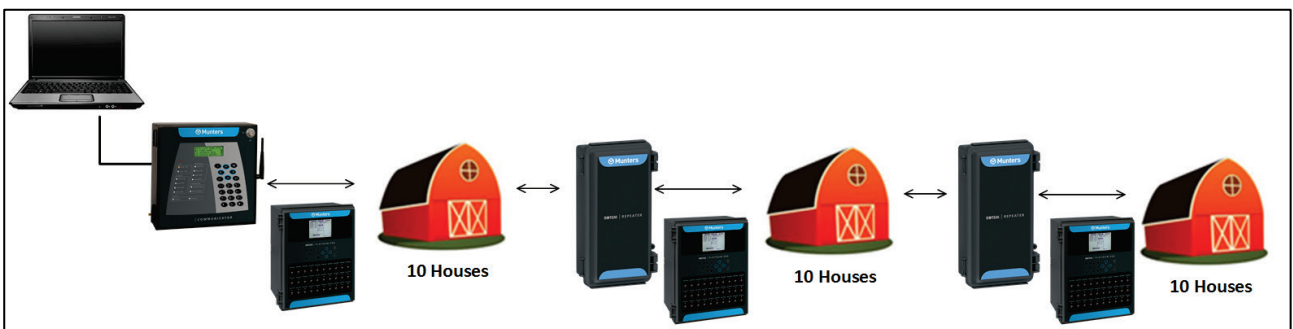
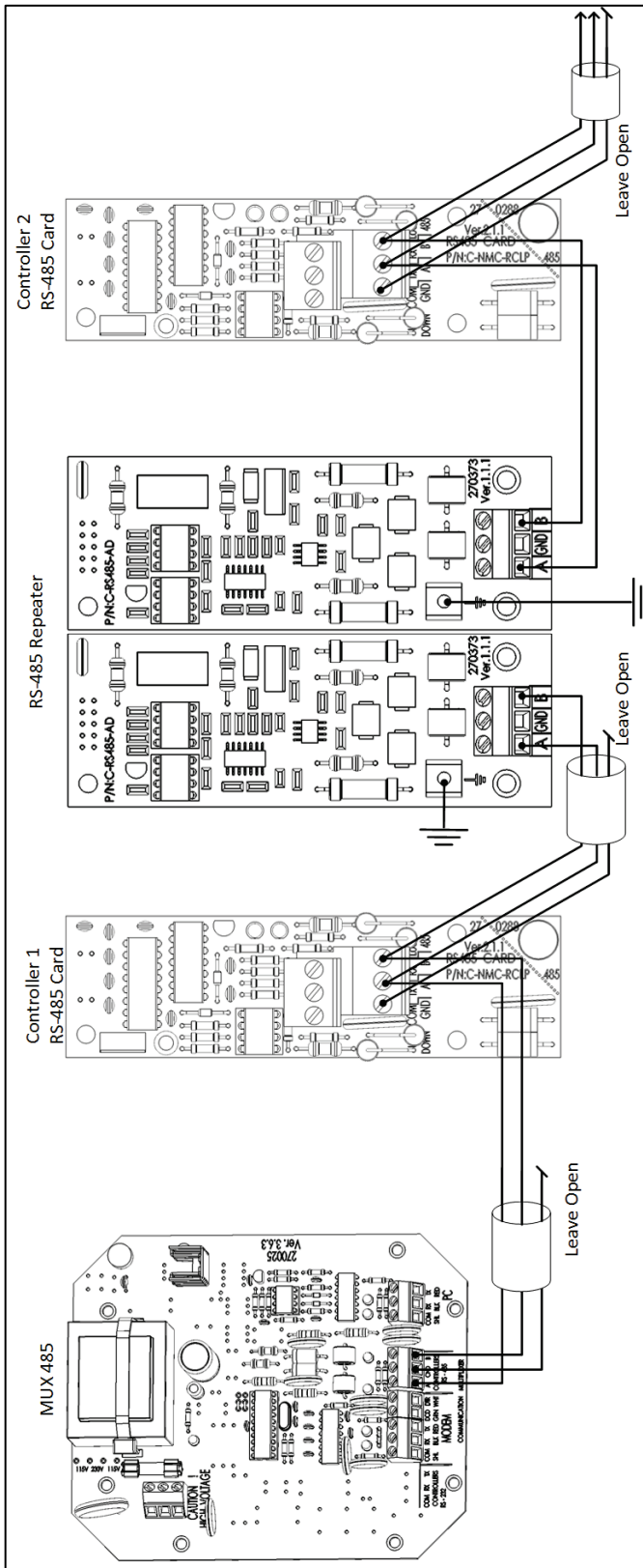

Figure 2: Daisy Chain Configuration

## 2.2 Wiring Diagrams



**CAUTION** Between each controller and repeater pair, ground one side only! In this drawing, the system is grounded on the repeater. You can ground each side as required as long as grounding is done on one side only!

Figure 3: MUX to Non-Isolated RCLP RS-485 Wiring

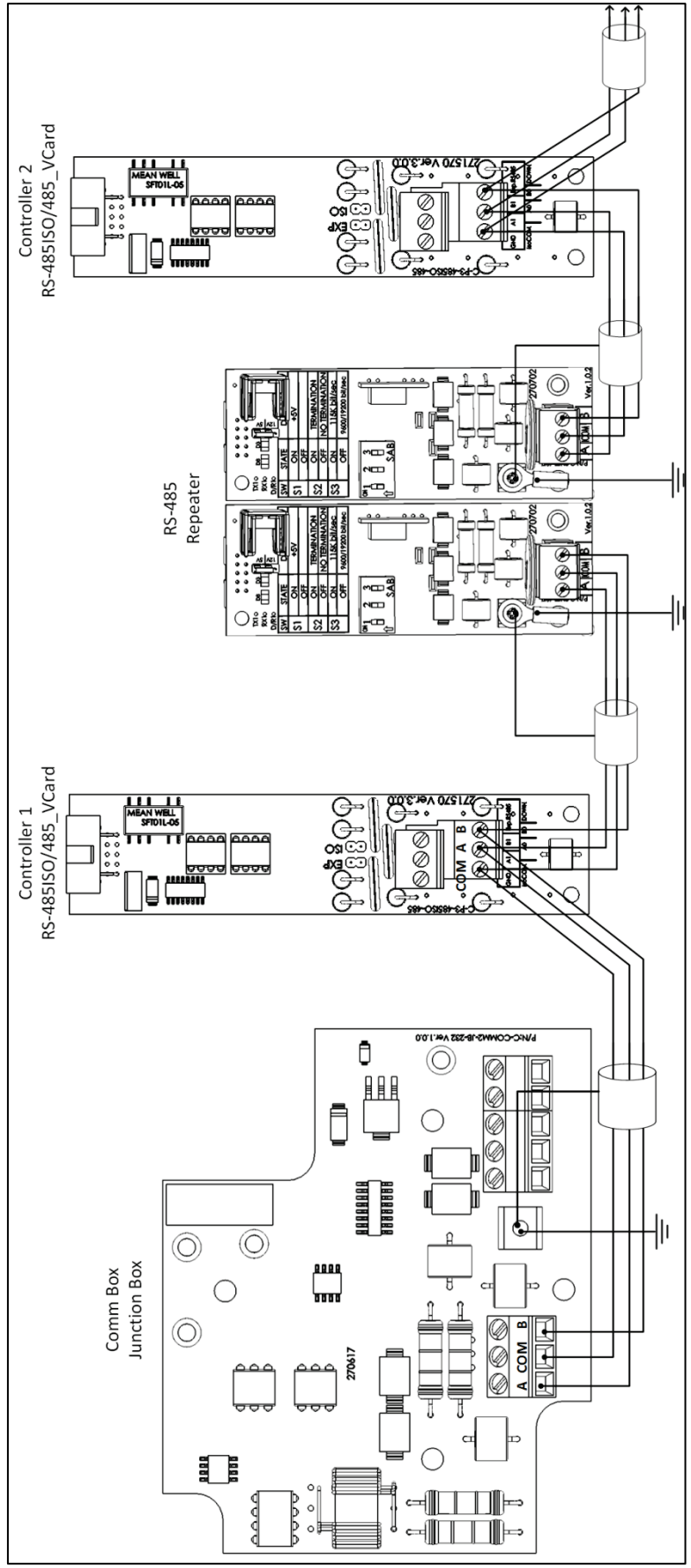

Figure 4: Comm Box to Isolated RS-485 Wiring



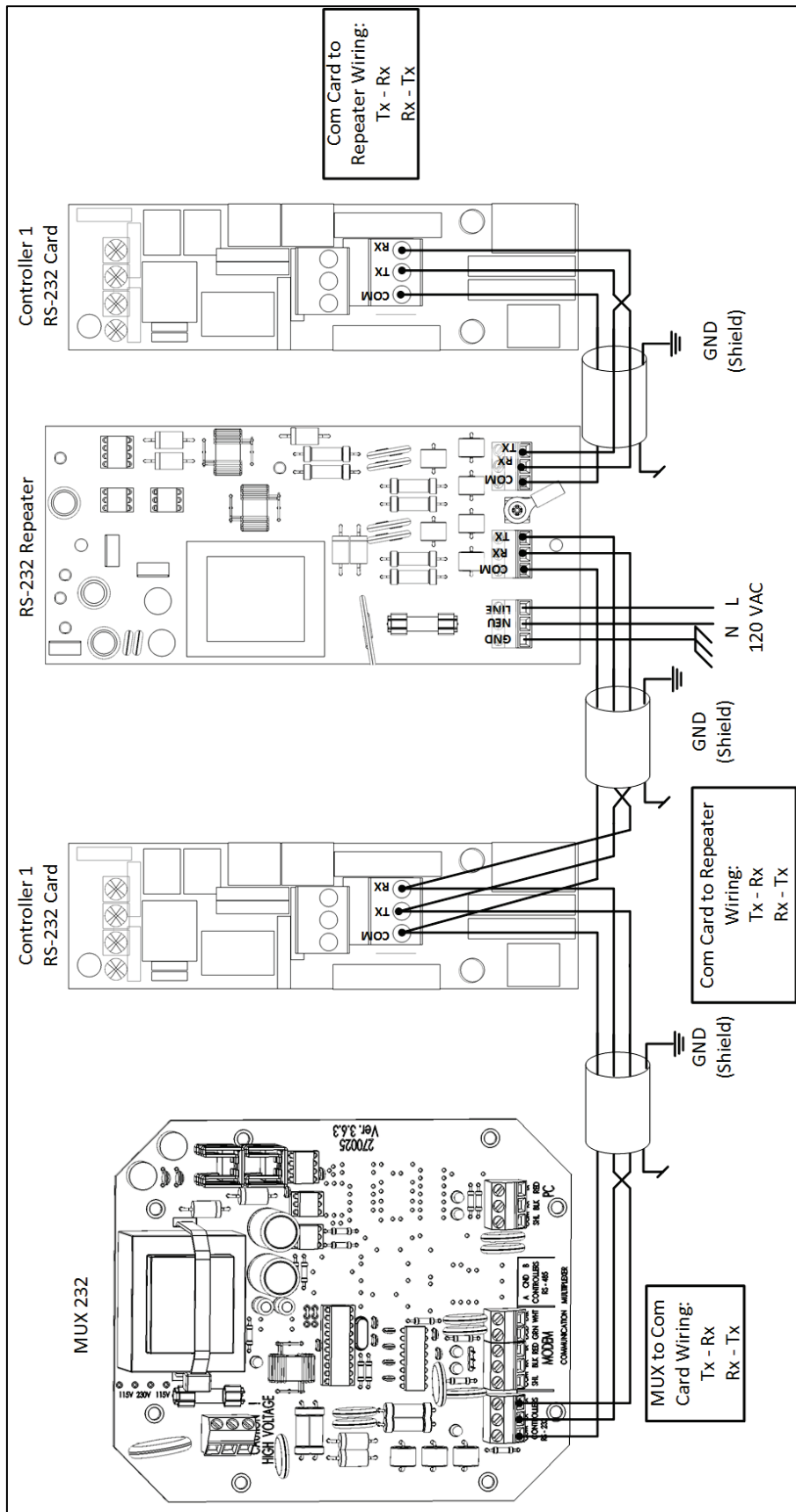

Figure 5: MUX to RCLP RS-232 Wiring

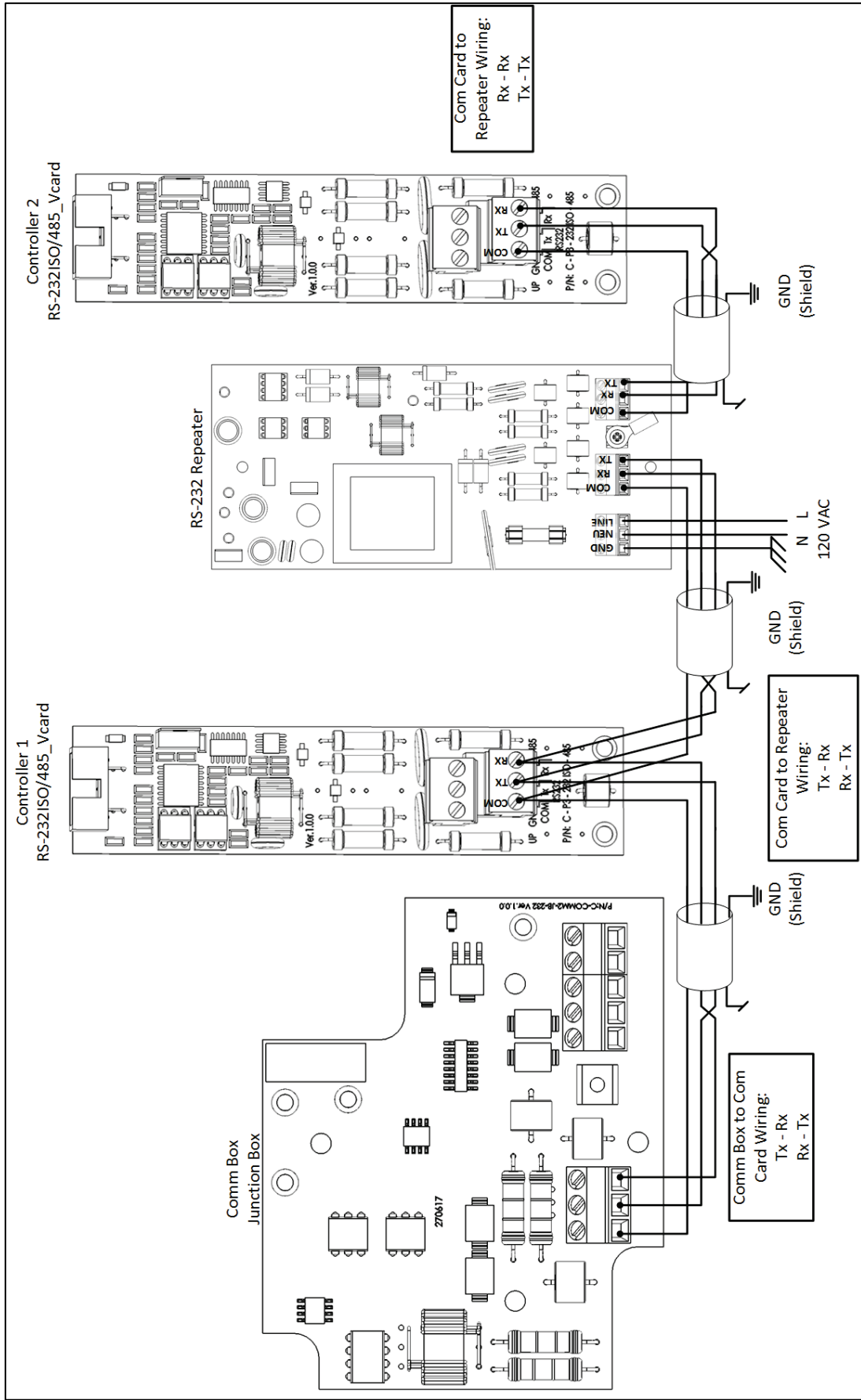

Figure 6: Comm Box RS-232 Wiring

# 3 Warranty

## Warranty and technical assistance

Munters products are designed and built to provide reliable and satisfactory performance but cannot be guaranteed free of faults; although they are reliable products they can develop unforeseeable defects and the user must take this into account and arrange adequate emergency or alarm systems if failure to operate could cause damage to the articles for which the Munters plant was required: if this is not done, the user is fully responsible for the damage which they could suffer.

Munters extends this limited warranty to the first purchaser and guarantees its products to be free from defects originating in manufacture or materials for one year from the date of delivery, provided that suitable transport, storage, installation and maintenance terms are complied with. The warranty does not apply if the products have been repaired without express authorisation from Munters, or repaired in such a way that, in Munters' judgement, their performance and reliability have been impaired, or incorrectly installed, or subjected to improper use. The user accepts total responsibility for incorrect use of the products.

The warranty on products from outside suppliers fitted to the Repeater, (for example cables, etc.) is limited to the conditions stated by the supplier: all claims must be made in writing within eight days of the discovery of the defect and within 12 months of the delivery of the defective product. Munters has thirty days from the date of receipt in which to take action, and has the right to examine the product at the customer's premises or at its own plant (carriage cost to be borne by the customer).

Munters at its sole discretion has the option of replacing or repairing, free of charge, products which it considers defective, and will arrange for their despatch back to the customer carriage paid. In the case of faulty parts of small commercial value which are widely available (such as bolts, etc.) for urgent despatch, where the cost of carriage would exceed the value of the parts, Munters may authorise the customer exclusively to purchase the replacement parts locally; Munters will reimburse the value of the product at its cost price.

Munters will not be liable for costs incurred in demounting the defective part, or the time required to travel to site and the associated travel costs. No agent, employee or dealer is authorised to give any further guarantees or to accept any other liability on Munters' behalf in connection with other Munters products, except in writing with the signature of one of the Company's Managers.

**WARNING:** *In the interests of improving the quality of its products and services, Munters reserves the right at any time and without prior notice to alter the specifications in this manual.*

The liability of the manufacturer Munters ceases in the event of:

- dismantling the safety devices;
- use of unauthorised materials;
- inadequate maintenance;
- use of non-original spare parts and accessories.

Barring specific contractual terms, the following are directly at the user's expense:

- preparing installation sites;

- providing an electricity supply (including the protective equipotential bonding (PE) conductor, in accordance with CEI EN 60204-1, paragraph 8.2), for correctly connecting the equipment to the mains electricity supply;
- providing ancillary services appropriate to the requirements of the plant on the basis of the information supplied with regard to installation;
- tools and consumables required for fitting and installation;
- lubricants necessary for commissioning and maintenance.

It is mandatory to purchase and use only original spare parts or those recommended by the manufacturer. Dismantling and assembly must be performed by qualified technicians and according to the manufacturer's instructions.

The use of non-original spare parts or incorrect assembly exonerates the manufacturer from all liability.

Requests for technical assistance and spare parts can be made directly to the nearest Munters office. A full list of contact details can be found on the back page of this manual.

#### **Munters Israel**

18 HaSivim Street  
Petach-Tikva 49517, Israel  
Telephone: +972-3-920-6200  
Fax: +972-3-924-9834  
[support@munters.co.il](mailto:support@munters.co.il)



[www.munters.com](http://www.munters.com)

**Australia** Munters Pty Limited, Phone +61 2 8843 1594, **Brazil** Munters Brasil Industria e Comercio Ltda, Phone +55 41 3317 5050, **Canada** Munters Corporation Lansing, Phone +1 517 676 7070, **China** Munters Air Treatment Equipment (Beijing) Co. Ltd, Phone +86 10 80 481 121, **Denmark** Munters A/S, Phone +45 9862 3311, **India** Munters India, Phone +91 20 3052 2520, **Indonesia** Munters, Phone +62 818 739 235, **Israel** Munters Israel Phone +972-3-920-6200, **Italy** Munters Italy S.p.A., Chiusavecchia, Phone +39 0183 52 11, **Japan** Munters K.K., Phone +81 3 5970 0021, **Korea** Munters Korea Co. Ltd., Phone +82 2 761 8701, **Mexico** Munters Mexico, Phone +52 818 262 54 00, **Singapore** Munters Pte Ltd., Phone +65 744 6828, **South Africa and Sub-Sahara Countries** Munters (Pty) Ltd., Phone +27 11 997 2000, **Spain** Munters Spain S.A., Phone +34 91 640 09 02, **Sweden** Munters AB, Phone +46 8 626 63 00, **Thailand** Munters Co. Ltd., Phone +66 2 642 2670, **Turkey** Munters Form Endüstri Sistemleri A.Ş, Phone +90 322 231 1338, **USA** Munters Corporation Lansing, Phone +1 517 676 7070, **Vietnam** Munters Vietnam, Phone +84 8 3825 6838, **Export & Other countries** Munters Italy S.p.A., Chiusavecchia Phone +39 0183 52 11