

Each Box includes:

- 1 - Celesco Potentiometer
- 1 - $\frac{5}{16}$ " - 18 x $\frac{3}{4}$ " Bolt
- 1 - $\frac{5}{16}$ " Keps Nut
- 2 - $\frac{1}{4}$ " - 20 x $\frac{3}{4}$ " Bolt
- 1 - Zip Tie
- 1 - FC1205 Terminal Block

UNPACKING THE EQUIPMENT

Before beginning installation, check the overall condition of the equipment. Remove packing materials, and examine all components for signs of shipping damage. Any shipping damage is the customer's responsibility and should be reported immediately to the freight carrier.

INSTALLATION INSTRUCTIONS



When replacing other Potentiometer Kits follow step 1 - 4, When adding AC1425 kits to BA4xxx without previous kits follow steps 5 - 8.

- 1) Remove bolt connecting beaded chain to BA4xxx cable pull bar.
- 2) Remove the chain from the bolt and reinstall the bolt to pull bar but do not tighten. (This can be reused to attach new potentiometer cable to the pull bar.)
- 3) Remove the (3) $\frac{1}{4}$ - 20 x $\frac{3}{4}$ " bolts holding the potentiometer bracket to the BA4000. **See Figure 1.**

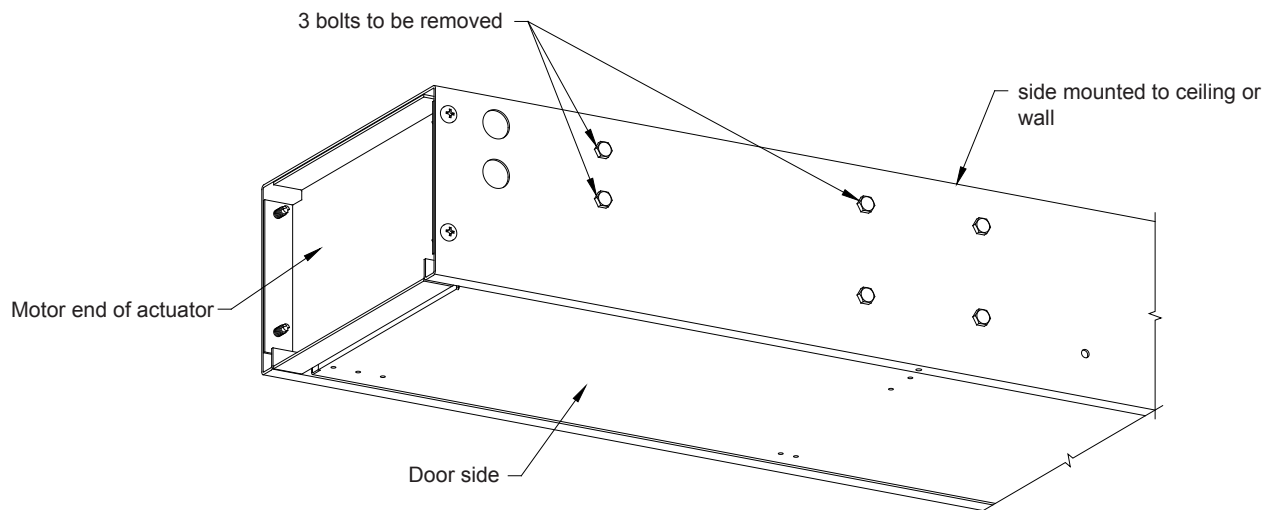

Figure 1

- 4) Install the $\frac{5}{16}$ " - 18 x $\frac{3}{4}$ " bolts and $\frac{5}{16}$ " Keps nut (provided) into the hole where the $\frac{1}{4}$ " - 20 x $\frac{3}{4}$ " bolt was removed from the lower bulkhead. **See Figure 2.**

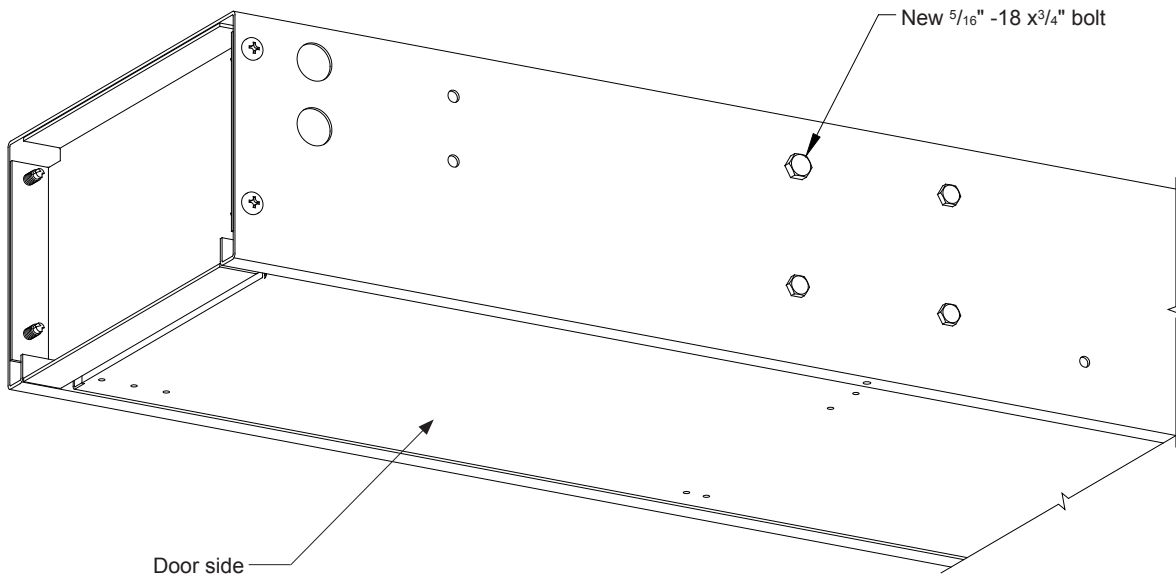

Figure 2

- 5) If the actuator already has the holes described below, then proceed to step 6.
Using a $\frac{9}{32}$ " drill bit, drill (1) hole at the $11\frac{5}{8}$ " from the motor end of BA4000 and $2\frac{1}{2}$ " from the top edge of the door opening. Drill a second hole $13\frac{1}{8}$ " from the motor end of the BA4000 and $2\frac{1}{2}$ " from the top edge of the door opening. **See Figure 3.**

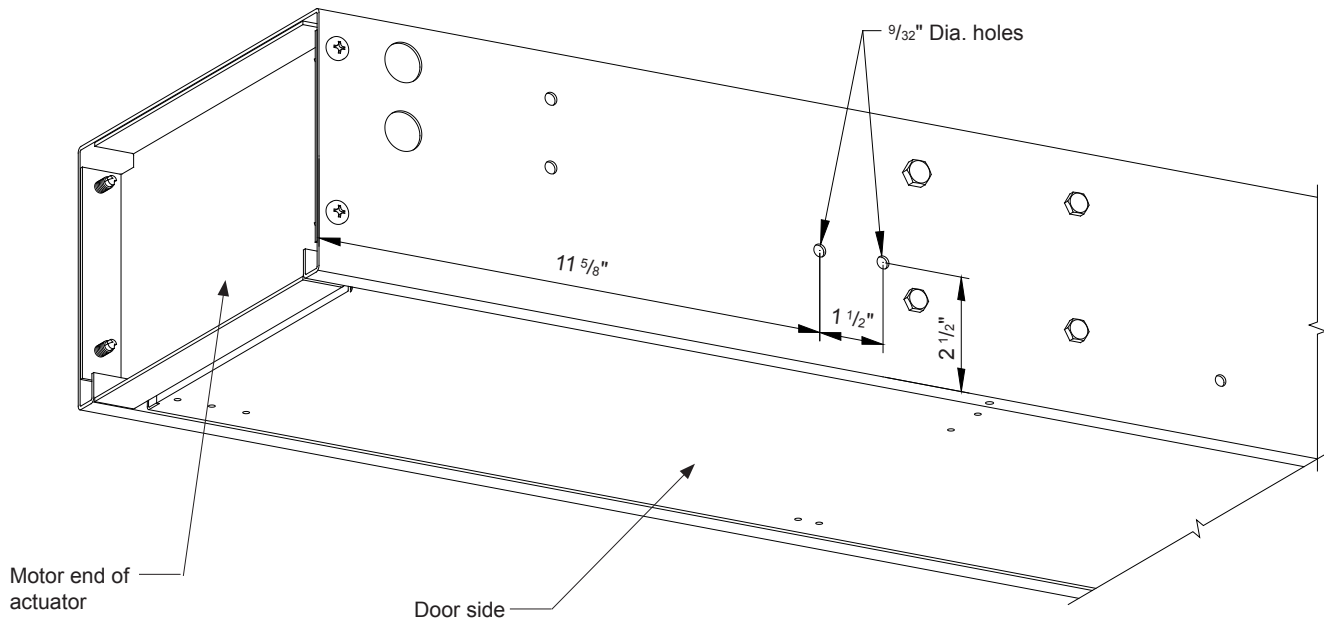

Figure 3

- 6) Position the Celesco potentiometer in the inside of the BA4000 over the new holes new holes with the cable coming exiting potentiometer and attaching to the cable bar (See Figure 4). From the outside of the BA4000, screw the (2) $\frac{1}{4}$ - 20 x $\frac{3}{4}$ " bolts provided through the new holes and into the threaded insets of the Celesco potentiometer bracket. **See Figure 4.**

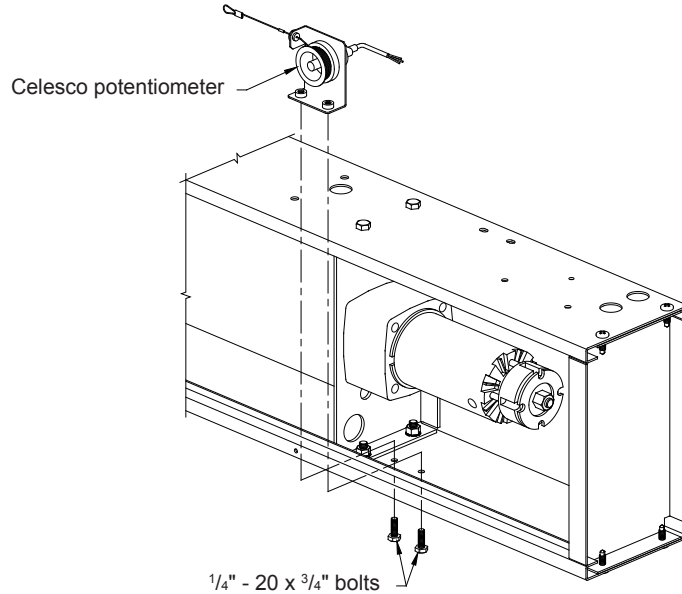

Figure 4

- 7) Feed the loop end of the Celesco potentiometer cable through the hole in the lower bulkhead (See Figure 5) and slip over the bolt that was left in the pull bar from Step 2. Snug this bolt, do not over tighten. A Zip Tie is provided for an alternate method of attaching the looped end to the pull bar.

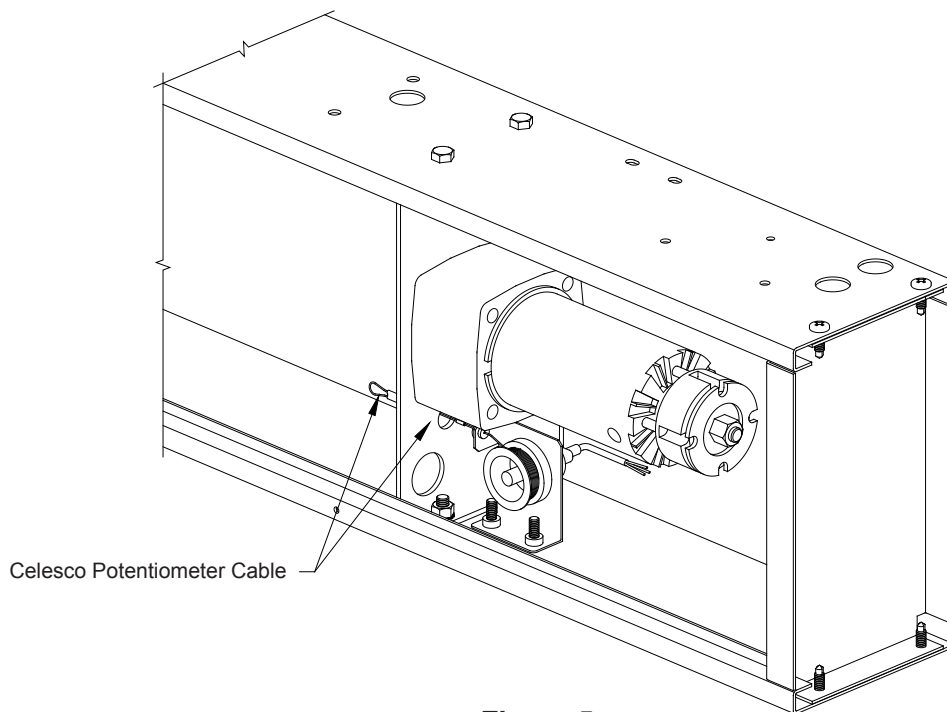

Figure 5

8) Attach the Celesco potentiometer wires to the terminal block. Red wire to red wire, green to white and black to black. **See Figure 6.**

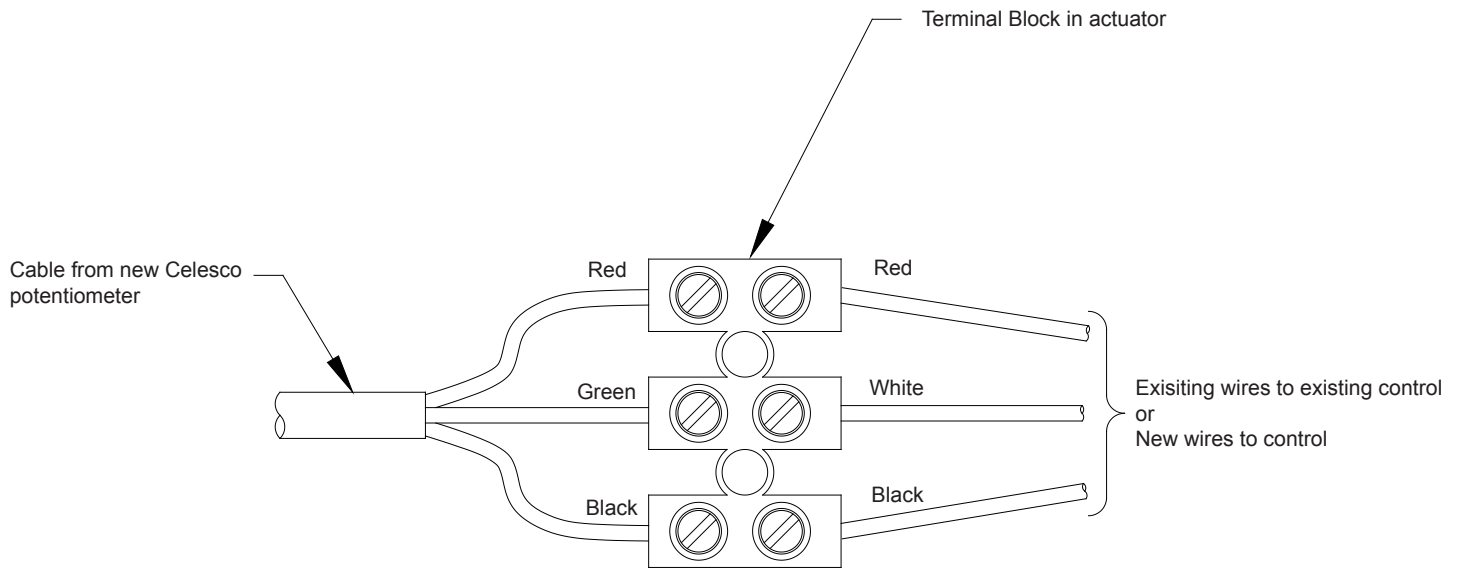

Figure 6